



## A GUIDE TO THE EARLY ENGINEERING MODELS IN PARSONS BLDG., T.C.D

This document explains the context for some of the historic engineering models on display in the Parsons Building in Trinity College Dublin. It is not intended as an academic work, but rather an informal guide to the models.

In the event that a reader spots an inaccuracy, please report this to me Garrett Lyons at [clyons@tcd.ie](mailto:clyons@tcd.ie)

### Preamble.

The first Industrial Revolution began in the closing days of the 17<sup>th</sup> century. It had dramatic social, political, and economic effects in Great Britain, but left Ireland virtually untouched. However, in the early 1800s (in a distressed\* and politically turbulent† Ireland) wise minds began to think of founding a Civil (*non-military*) Engineering course of studies in Trinity College Dublin, The proposal to do so was accepted by the Board of TCD and so in 1841 the Engineering School opened its doors for business. The course of studies was to have a very strong emphasis on the teaching of 'engineering science', a happy marriage between the mathematical and physical sciences and engineering technologies. This was most important to Humphrey Lloyd the then Professor of Natural & Experimental Philosophy who, with and perhaps more than others, pushed for the founding of an Engineering School. He made his attitudes very clear in his 1841 memorial to the Board of TCD (see Appendix 1).

The course was to be of two years duration and encompassed the topics of:-

- 1<sup>st</sup> year: Mathematics, Principles of Mechanics, Chemistry & Geology.
- 2<sup>nd</sup> year: Practical Mechanics, Heat and the Steam Engine,  
Practical Engineering.

So TCD was to teach engineers in the European manner and not grant diplomas to '*rude mechanicals*'.‡ We should also note the use of the word 'heat' and be aware that the subject of Thermodynamics had not, at this stage even been given its name, indeed the Second Law had not as yet been formally stated (see Appendix II).

Now the engineering models, some of which are on display in Parsons Building, others in the Museum Building (<http://www.tcd.ie/Maps>), were bought in the early years of the Engineering school and were intended as teaching aids in bringing together theory and practice. Although we may now look at them with a degree of nostalgia and amusement 'that engineering was then so simple', they represented the 'High Tech' of their day. To fully understand this we need to look back a little and see the history of the development of steam devices, and what were the economic and social forces driving the invention and construction of the expensive machines these models represent.

**Steam Devices.** As is well known Hero (or Heron) of Alexandria ~10-70AD developed the aeolipile, a simple steam reaction turbine, in truth more a toy than a machine, which he later described in his text '*Pneumatica*'. In the early 1500s a number of translations of *Pneumatica* appeared in France, the German states and Italy. This led to machines being developed in 1548 by the Spanish sea captain and

---

\* The portents of the great Famine were already being felt, see '*The Great Hunger: Ireland 1845-1849*'. by Cecil Woodham Smith. Fredric Davidson . ISBN: 0241114101.

† See '*The liberator: Daniel O'Connell and the Irish party, 1830-1847*'. by Angus Macintyre. H. Hamilton, 1965.  
'*Conflict in 19<sup>th</sup> Century Ireland*'. by Rees Russell, Colour Point books. ISBN 9781 1 906578558

‡ See Buchanan R A, (1985) "The Rise of *Scientific Engineering in Britain*". The Brit J for the History of Science. Vol 18, #2, pp218-33

inventor Blasco de Garay (1500-1552), and by the great Neapolitan polymath Giambattista della Porta (1535-1615), who in 1606 was the first to show that steam could be utilized to drive water by drawing it into a vacuum formed by condensing steam. There is talk of a French Huguenot engineer, Salomon de Caus (1576-1626) who, whilst in the service of the son of the English Monarch James I, invented such a device and also of a David Ramsay in 1630 creating an engine to "*To raise water from lowe pittes by fire*". Nothing is known of the details of this last machine. However, it does highlight the great problem of mine drainage even in these early years.

In 1661 experiments by Otto von Guericke utilized a vacuum to raise a piston fitted in a cylinder and also showed useful work could be done by such a device. (*We now have the elements of the steam engine*). Books by Caspar Schott spread Guericke's work and one published in 1657 reached Robert Boyle<sup>§</sup> in England. The last stages to the pre-development of the engine now began.

Edward Somerset, the marquis of Worcester, had a book printed in 1665 in which he described some 100 inventions, one of which was his '*water commanding engine*'. The description of the engine in the text is purposely so convoluted and obscure it is impossible to determine any details of the machine. No drawings of it exist. However, it does appear he was experimenting with high pressure steam. There is a nonsensical story of Savery (see below) buying all the copies of the book of inventions in order to burn them and so hide Somerset's invention.

Denis Papin a noted French scientist worked under Christian Huygens on an engine in which a piston was moved by the force of explosion of some gunpowder. The revocation of the Edict of Nantes (1658) caused Papin to flee to England where he worked with Robert Boyle. In 1690 Papin proposed to gain motive power by the force of atmospheric pressure on a piston behind which is a vacuum produced by the condensation of steam (*the exact concept of Newcomen's engine*). Papin wrote: - "*Since it is a property of water that a small quantity of it turned into vapour by heat has an elastic force like that of air, but upon cold supervening is again resolved into water, so that no trace of said elastic force remains, I conclude that machines wherein water, by the help of no very intense heat, and at little cost, could produce that perfect vacuum which could by no means be obtained by gunpowder.*" He actually made a laboratory device which, though it showed the validity of his thoughts, was not a practical machine.

So it came to Thomas Savery F.R.S, an English military engineer, experimental scientist and civil servant (and a shrewd businessman) to gain in 1698 the first patent for a steam engine –'The Miners Friend' (display case 1). It is to him is given the title of 'Father of the Steam Engine'; although his brilliant device was seriously flawed and inferior in many ways to Papin's constructs. In truth it failed to be successful at mine drainage and was used primarily to provide water either for human consumption or fountains in the homes of aristocrats. Valenti\*\* attributes Savery's dominance to a conspiracy, both on the part of the British parliament and also the Royal Society. Although this is not proven Valenti does give good description to Papin's work and of his collaboration with the renowned Gottfried Leibniz.

So all through these years we see again the interweaving of the sciences and technologies to create a useful device and we arrive at the stationary steam engine. The next significant step was made by Thomas Newcomen, who in 1712 created the first steam engine to bring real economic benefits. His engine was really an embodiment of many elements invented by others, in that it used condensed steam to create a vacuum and atmospheric pressure to act on a piston. Newcomen like Savery used a water spray to cause condensation of the steam, which is of course very inefficient. Indeed it was said of Newcomen's engines that '*you needed his engine to drain a mine, and a coal mine to run it*'.

---

<sup>§</sup> Robert Boyle FRS born in 1627 at Lismore Castle Waterford was the seventh son of the 1<sup>st</sup> Earl of Cork.

Independently wealthy he spent his life in scientific research and is probably best known for his law on the PV properties of gases "Boyles Law". His work with air pumps was published in 1660 under the title *New Experiments Physico-Mechanicall, Touching the Spring of the Air, and its Effects*.

\*\* Valenti, Philip. '*Papin, and the Steam Engine; A case study in British Sabotage*'.

<https://www.21stcenturysciencetech.com/>

One of Germany's great inventors and mathematicians - Jacob Leupold (1674-1727) - described a high-pressure non-condensing twin piston steam engine<sup>††</sup> in his book "Theatri Mechinarum Generale". The text shows pictures of the engine, which was hugely before its time. I cannot determine if it was ever constructed.

The other great advancement was that of James Watt who in 1769 was granted a patent for the 'Separate Condenser' (display case 2). The protection afforded by this patent enabled *Watt* in collaboration with *Matthew Boulton*, who was a financier and manufacturer, to exert a very tight rein on the whole of the steam engine industry until 1800.

At the end of the 18<sup>th</sup> century Watt began to perfect the double-acting principle for his engines, whereby the steam pressure acted in turn on both sides of the piston, and a number of non-rotating pumping engines were manufactured to this design. After Watt there was significant progress in the design of steam engines for greater thermodynamic efficiency. With high pressure engines and the development of engines of the Maudslay's type and oscillating engines (display case 2). Finally compounded and double & triple expansion engines of greater and greater power and physical size were created for stationary purposes – the pumping of mines, provision of clean water to towns and power for manufacturing. These are well described in the literature, see for example Dickinson<sup>‡‡</sup>.

There is, of course, the story of steam locomotion which we must briefly address. The first hint we have of road transport is the work of a Flemish Jesuit, Fr. Ferdinand Verbiest (1623–1688), who was a missionary in China during the Qing dynasty. He was an accomplished mathematician and astronomer and through his works, both theoretical and practical, became a friend of the Xangxi Emperor. Verbiest also experimented with steam and in about 1672 he designed as a toy for the Emperor, a steam-propelled trolley which was, possibly, the first working steam-powered vehicle. The device was small and could not carry a human so perhaps calling it a car is incorrect. However it was a mobile device in which steam generated in a spherical boiler, emerged through a pipe at the top, from where it was directed at a simple open steam turbine that drove the rear wheels, see accompanying figure.



In 1769, a steam driven self-propelled road vehicle was designed by French engineer and mechanic, Nicolas Joseph Cugnot (1725 - 1804). It was a three-wheeled vehicle and was used by the French Army to haul artillery at the astonishing speed of 3.5 km/h. However, the vehicle had to stop every ten to fifteen minutes to build up steam power. In 1770, Cugnot built a steam-powered tricycle which carried four passengers.

In 1789 Oliver Evans was granted the first U.S. patent for a steam-powered land vehicle. In Britain in the year 1801 the great pioneer of high pressure steam Richard Trevethick built a steam driven road carriage and from about 1820-40, steam-powered stagecoaches were in regular service. Steam locomotion also found a place in agriculture in the form of steam ploughs and traction engines.

Road vehicle development went apace in Europe & America with, for example, steam-driven Charabancs carrying passengers in Paris and elsewhere and 'cars' such as the one built by Amadee Bolee. In 1878, Bolee designed "La Mancelle". Fifty of these cars were manufactured so it is perhaps the first automobile

<sup>††</sup> See Galloway Elijah, "History of the Steam Engine" London. B.Steil, Pater Noster Row , 1828, pp23-24

<sup>‡‡</sup> Dickson HW. "A Short History of the Steam Engine" Frank Cass & Co., London 1963

to be put into series production. The car had advanced features; rear-wheel drive (via shaft to the differential and then via chain to the rear wheels) & independent suspension on all four wheels.

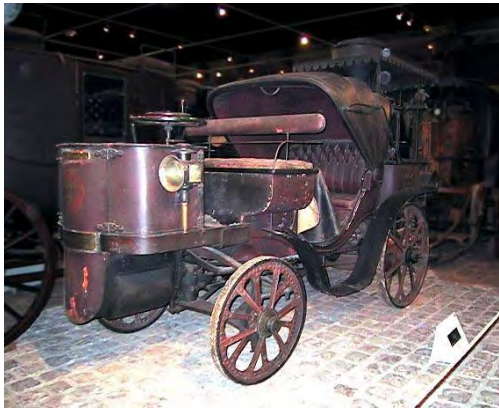

External combustion engine steam road cars & charabancs continued to be developed and built until after the advent of the internal combustion engine car and persisted until about the 1920's.

However, we should be aware that some noted auto manufacturers (General Motors, Saab etc.) have undertaken research into steam driven vehicles up to about the 1970's. So who knows?

### **La Mancelle**

The steam engine was, as we all know, used for rail locomotion and some of this story goes back to the earliest period. Periander, one of the seven sages of Greece is credited with the development of a 'man hauled' rail-or-tram way. By rail or tram we mean a method by which goods &/or people are conveyed by means of wheeled vehicles running on rail/tram tracks. They are thus directionally constrained and guided by the tracks on which they run and so it is very different to the freedom of road conveyance.

There is a long story to be told, but we have not the time or space here for it. It is well described in a plethora of books for example<sup>§§</sup>.

To give some little idea of the history let us restrict ourselves to Britain and just note some important dates.

In 1767 the first iron rails (cast iron) were laid at Coalbrookdale. In 1804 Richard Trevethick's rail locomotive 'Wylam' ran on rails at Samuel Homfray's Pen-y-Darren mine in Wales. Homfray was so impressed with Trevithick's engine that he made a bet with a Mr., Crawshay for 500 guineas (~650 €) that Trevithick's steam locomotive could haul 10 tonnes of iron along the Merthyr Tydfil Tramroad from Pen-y-darren to Aberconyn - a distance of 15.7 km. Amid great interest from the public, on the 21 Feb 1804 it successfully carried 10 tons of iron, 5 wagons and 70 men the full distance in 4 hours & 5 minutes, an average speed of 3.9 km/h- and so rail travel became a reality.



**A Replica of 'Wylam' at the Waterfront Museum Swansea.**

<sup>§§</sup> Gourvish T.R. 'Railways and the British economy 1830-1914' . London: Macmillan, 1980

In 1808 Trevethick took one of his Cornish engines 'Catch-me-who-Can' to London for a demonstration in which his locomotive ran at 19kph on a circular track. He charged one shilling (£0.042) a ride – this demonstration proved the practicality of a locomotive with smooth wheels on a smooth rail-track.

**Trevetick’s demonstration at Russell Sq, London**

By 1815 the Stephenson’s engine ‘Blucher’ ran at the Killingworth Colliery and could pull a train of 30 tonnes at a speed of 6.5 km/h up a gradient of 1 in 450.



In 1829 an Act of Parliament allowed the opening of the Liverpool to Manchester passenger and goods railway and by the year 1845 thirty million passengers had travelled by rail.

Our model Pyracmon (main hall) is of a small 0-6-0 goods locomotive which ran on the Great Western Railway line. [The 0-6-0 refers to the method of describing wheel configuration on locomotive engines, in this case, 0 leading wheels, 6 powered driving wheels, and no trailing wheels.]

The underground railways of the great cities of Europe of course initially used steam locomotives, many of very cunning design. They were superseded in the late 1890’s by electric locomotion, the power for which was generated by machines driven by stationary steam engines<sup>\*\*\*</sup>.

Above ground railway locomotion by steam developed and persisted throughout Europe and the USA until the 1960s, when it was superseded by either electric or diesel-electric locomotives. Steam still has some small foothold in many countries, mainly by the good work of heritage societies.

For the important stories of underground rail and of marine steam, other than that of the steam turbine and its development I must again guide the reader to the abundant literature that exists<sup>††† ‡‡‡</sup>.

The steam turbine is the only form of external combustion to survive extinction by superior technologies. A brief time line of its development in the 15<sup>th</sup>-19<sup>th</sup> centuries runs as follows:-

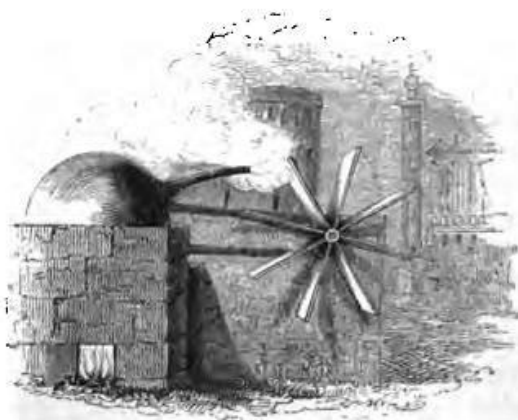

In 1629, the Italian engineer Guissepe Branca described in his book ‘*Le Machine*’ the steam turbine he had invented. This machine had a wheel with ‘paddlewheel’ vanes, being rotated by steam produced in a closed vessel and directed at the vanes via a pipe. Branca suggested that it might be used for powering pestles and mortars or for power to saw wood.

**Branca’s turbine**

This was followed in 1642 by Althanasius Kircher who described a Branca turbine, but with double steam jets. In 1784 James Watt was granted letters patent for improvements to steam engines, one such related to a steam turbine.

\*\*\* Day, John R.; Reed, John (2008) [1963]. *The Story of London's Underground*. Capital Transport. ISBN 978-1-85414-316-7.

††† Fletcher RA. “*Steam Ships: the story of their development to the present*” 1910

‡‡‡ Chatterton. E.K.C. “*Steamships & their story*”. Cassel & Co Ltd., London 1910

In 1809 a patent #3289 was granted to Noble in which he describes his steam turbine, "Steam proceeds from Boiler A and by pipe B impinges on the wheel C and forces to wheel to rotate in the direction of the arrow. The ratchet and pawl E, F prevent contra rotation"; A working device?

### Noble's Steam Turbine

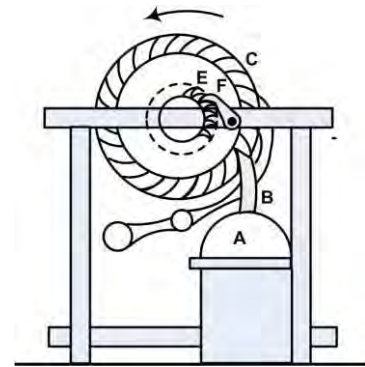

Now the four men we commonly portray as the pioneer inventors of 'real' steam turbines are Carl Gustav de Laval (1883, Hero - reaction turbine), Charles A. Parsons (1884), Auguste C.E. Rateau (1894, impulse turbine), and Charles G. Curtis (1897). Each invented (patented in the years indicated) & developed a steam turbine. However, the most significant major breakthrough in steam turbine technology is associated with the Hon., Charles Parsons for his invention of a successful steam turbine (reaction multi stage axial flow type) it was designed to drive the new electric generators, and the problems were so complex that they could only be resolved by combining all the available resources of mathematics, science, and machine design. Parsons happily embodied all of these and also possessed a fine business mind.

It is after this great Irishman that our building is named and an example (not a model) of his turbo-generator is displayed in the main hall (see separate notes for information).

But what were the forces driving the creation of all these machines?

#### The economical & socio/political pressures:

Mining for coal & metals in both England and mainland Europe was a most important industry from the middle ages. As time passed and surface or shallow reserves became exhausted deeper and deeper pits had to be used. Because of this mine drainage problems became the plague of the industry. Many and varied methods were adopted to solve drainage problems, water, windmill, human and horse driven pumps, soughs and adits were in regular use. The costs associated with these methods were crippling and in England, even after the disestablishment of the monasteries and the take over and exploitation of monastic mines by wealthy landowners, they could not be borne. In the German states, later adopted in Sweden, Norway and Liege/Mons, a cunning system called 'Stangenkunst'<sup>§§§</sup> (long-rod art) was invented. This system used linked 4-bar mechanisms and worked well to solve mine drainage problems and, although I can find no supportive statement, the technique presumably was economical. Strangely the technology of Stangenkunst did not seem to penetrate into England and so drainage problems worsened as pits got deeper. The literature is full of instances of collieries, in both England & Scotland, whose losses reached sometimes to £20,000 with flooding being the main cause<sup>\*\*\*\*</sup>.

The foregoing is a very good reason why Britain should lead in the development of steam engine. But why was it in the position to do so and; why did it blossom so rapidly? There are many and varied arguments as to why. The dichotomy between Catholic dogma and the Cartesian methodology versus the new science of Bacon & Newton, readily embraced by the Anglicans, was one. The relative value of mining to England's economy when compared to that of other regions of Europe is another. This is a rich ground for philosophical debate & not for these pages. However, there are a few things we should note:-

1. In 1700 England produced 80% by tonnage & 59% by value of all metals in Europe. Germany, which led the field in the Middle Ages, accounted for only 4 & 9% respectively<sup>††††</sup>. So the magnitude of mining in England must have created a great urgency to find a solution of the drainage problem.

<sup>§§§</sup> Noble H. 'Mechanism and Machine Theory' Elsevier 1974.

<sup>\*\*\*\*</sup> Hatcher J. 'The history of the British Coal Industry. vol.1 Before 1700: towards the age of coal' Oxford 1993

<sup>††††</sup> Allen R. 'The British industrial revolution in global perspective'. Cambridge 1982.

2. The great ferment of the industrial revolution in all aspects of manufacture and its need for power systems to drive cotton gins, weaving looms, furnaces, metal presses and forging hammers. The development and growth of 'industrial' towns and the necessity of providing 'clean' water for their populations.
3. The almost impassible state of the roads in 17/18<sup>th</sup> century Britain, which forced the construction, first of canals for the transportation of manufactured goods, then as soon as locomotion became a possibility the creation of the railways. The economics of these steps speak for themselves, see Table I.<sup>+++</sup>

Velocity of Motion (mph)	On a Canal (lb)	On a level Railway (lb)	On a level turnpike road (lb)
2.5	55,500	14,400	1,800
3	38,542	14,400	1,800
6	9,635	14,400	1,800
9	4,282	14,400	1,800
13	1,900	14,400	1,800

1lb=0.454kg 1 mph=1.61km/h

**Table I Weights Moved by the Application of equal forces**

Finally the discovery of the vacuum and more so the debates between the Newtonians & the Cartesians on 'states of being' and on what constitutes the proper methodology of science would have all been irrelevant unless the focus of scientists and fabricants had not been on the solution of practical problems. England in these important years benefited from its learned societies, such as the Lunar Society<sup>§§§§</sup>, and indeed even the Royal Society had this focus. We may note that the then official objective of the Royal Society was: *'to improve the knowledge of natural things, and all useful arts, manufactures, Mechanic practices, Engines & inventions by experiment'* and so at this period in Britain a fertile soil existed for the invention of the steam engine.

**And So to The Models**

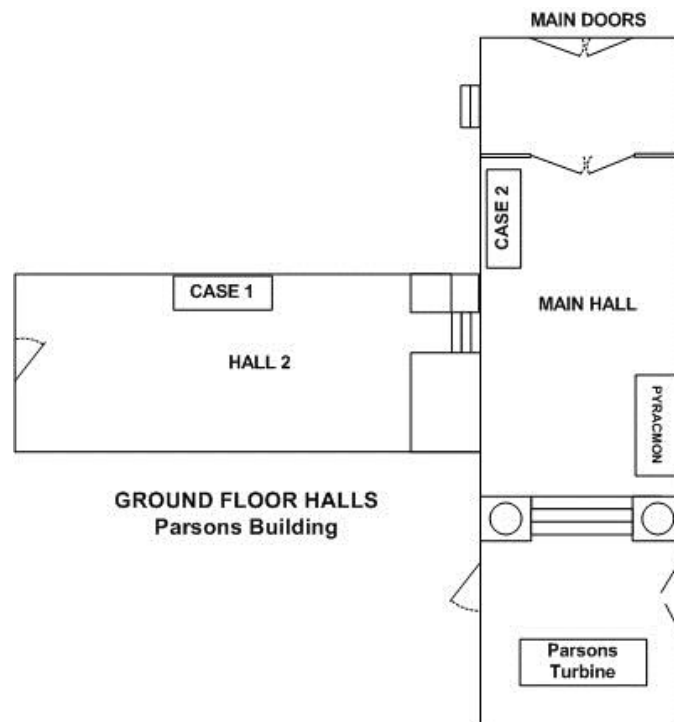

<sup>+++</sup> 'Penny Cyclopedia' London 1825

<sup>§§§§</sup> May I encourage the reader to indulge in Jenny Uglow's excellent book *'The Lunar Men the friends that made the future'* Faber & Faber, London 2002. It is an easy read and enthrallingly explains the ferment of the time.

## Display Case 1

**Hero's Aeolipile:** (~10-~70 AD). The first mention of the word 'aeolipile' is by Vitruvius in his book 'De Architectura (1BC)' chapter VI where he declares the aeolipile as 'a scientific invention to discover a divine truth lurking in the heavens', but no drawings or technical description survive.

There is very little known of Hero (or Heron) other than what can be gleaned from his writings which include works on Mechanics, machines of war, geometry and surveying. He developed many instruments & machines including the aeolipile which he tells of in the 'Pneumatica'. It may be described as "a hollow sphere mounted so that it can turn on a pair of hollow tubes that provide steam to the sphere from the cauldron. The steam escapes from the sphere through some bent tubes projecting from its equator causing the sphere to revolve.

JD Langells made several models of the aeolipile and found when the steam had overcome the inertia of the sphere etc and the friction of the bearings it would spin at speeds of 1,500 rpm.

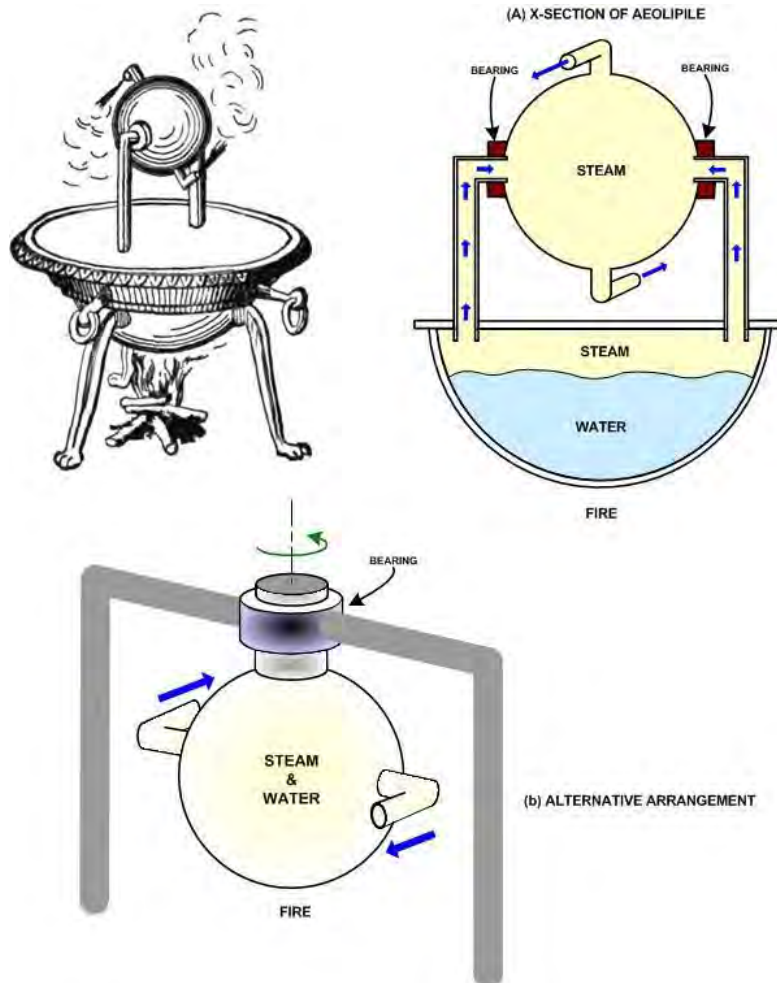

Author's Note: There are many design aspects of the aeolipile that are a cause for query. 1<sup>st</sup> For anything like lengthy running the necessary bearings (shown in (A)) would have to most carefully made and still maintain a very close tolerance on the 'tubes' when all had become heated by the steam. 2<sup>nd</sup> The central axes of the tubes horizontal sections would both have to perfectly aligned for the device to run. I doubt that manufacture at the time was good enough for all this to be achieved. Even if an alternative approach such as shown in (B) was adopted, bearing and lubrication problems would remain. The very speed of the device makes gearing necessary to extract any useful work from it and the 'peg and lantern' type gearing used in Egypt at the time would not be capable of running at a speed of 1,500rpm. It is my contention that the device was made with significant geometric clearances on the bearings and was therefore leaky and thermodynamically very inefficient & so was no more than an interesting toy.





**Savery's Pumping Engine:** Thomas Savery was born circa 1650 into a wealthy family in Devonshire. He was well educated and became a military engineer. Savery exhibited great fondness for mechanics and for natural philosophy and gave much time to experimenting, to the contriving of various kinds of apparatus, and to invention. Among his many inventions, he constructed a clock which still remains in the family and is considered an ingenious piece of mechanism. It is said to be of excellent workmanship.

Savery continued the work of della Porta and Papin to produce a simple pumping engine. He successfully pleaded to be allowed to demonstrate a model of his 'Fire Engine –The Miners Friend' to King William II & his court, The Royal Society of London and The Society of Merchant Venturers. He was quickly granted a patent., the title of which read: "*A grant to Thomas Savery of the sole exercise of a new invention by him invented, for raising of water, and occasioning motion to all sorts of mill works, by the important force of fire, which will be of great use for draining mines, serving towns with water, and for the working of all sorts of mills, when they have not the benefit of water nor constant winds; to hold for 14 years; with usual clauses.*" This patent was to have consequences for Newcomen!

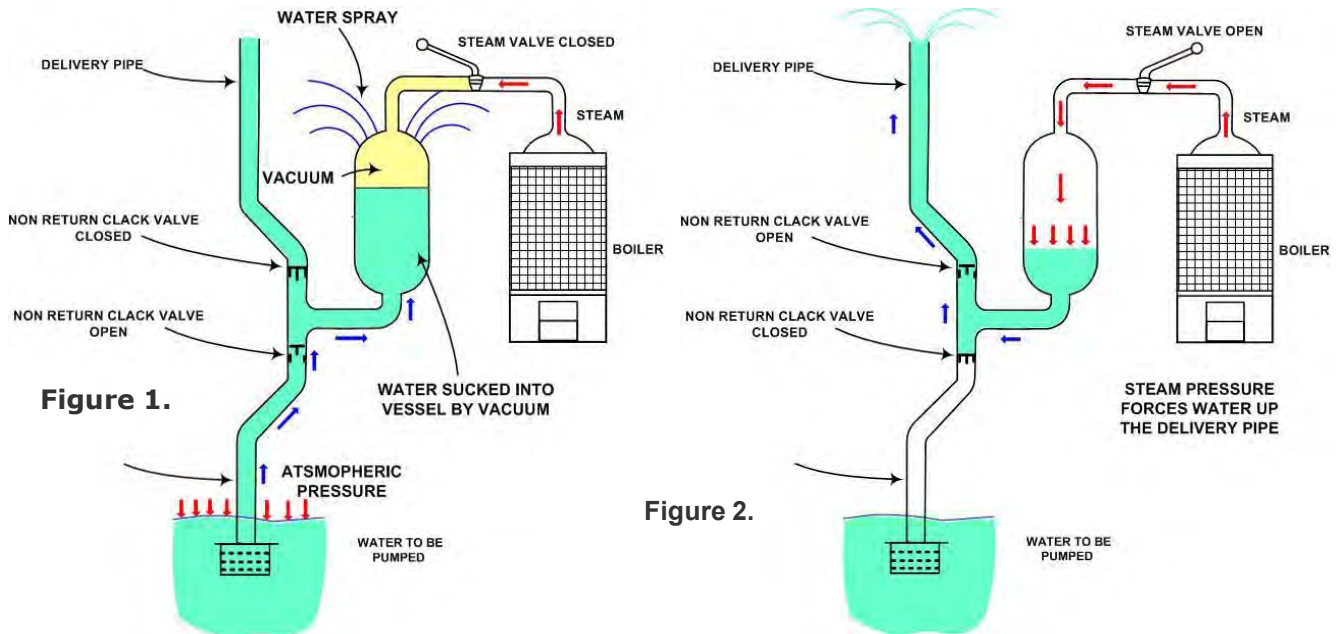

The engine is fairly simple in operation, having a cycle of two phases.

In the first phase, Figure 1, the **suction mode** the non return valve in the delivery pipe is held closed by the weight of the standing column of water above it. The steam valve is opened to fill the vessel with steam & is then closed again. A water spray is then directed on the outer surface of the vessel which condenses the steam & so causes a vacuum within the vessel. Atmospheric pressure acting on the surface of the flood water then forces water up the suction tube.

In phase 2, Figure 2, the **pumping mode** the steam valve is opened to allow steam pressure to build within the vessel. The resulting force acting on the water in the vessel forced the non-return valve in the suction pipe to close and to force the water out of the vessel and up the delivery pipe. The cycle then repeats. We should note that the steam valve had to be opened and closed manually, a laborious task.

Savery's pumps were not very successful. They were limited by physics. We know the max height to which water can be drawn by a vacuum is 10metres. So this is the maximum length of the suction tube. The greatest recorded delivery height for water from the engines was ~24m (limited by low pressure steam from the poor boilers of the time). It is not clear whether this was from vessel to tip of delivery pipe or total height. Taking it to be the former the maximum height of delivery was 34m. In the deep Cornish

mines this meant the pumps would have to be within the pit itself and perhaps a number of them would have to be positioned one above the other. Neither of these factors are desirable ones.

**Thomas Newcomen's Engine:** There is no known portrait of Newcomen (1662/3-1729), nor is the exact site of his grave known. Because Savery had an exclusive patent, which was extended to expire in 1733, Newcomen had to work with him in order to market his engine. Newcomen died in relative poverty while Savery prospered. By the time of Newcomen's death about 75 of his engines, still operating under Savery's patent, had been installed in most of the important mining districts of Britain: draining coal mines in the Black Country, Warwickshire and near Newcastle upon Tyne; at tin and copper mines in Cornwall; and in lead mines in Flintshire and Derbyshire, amongst other places.

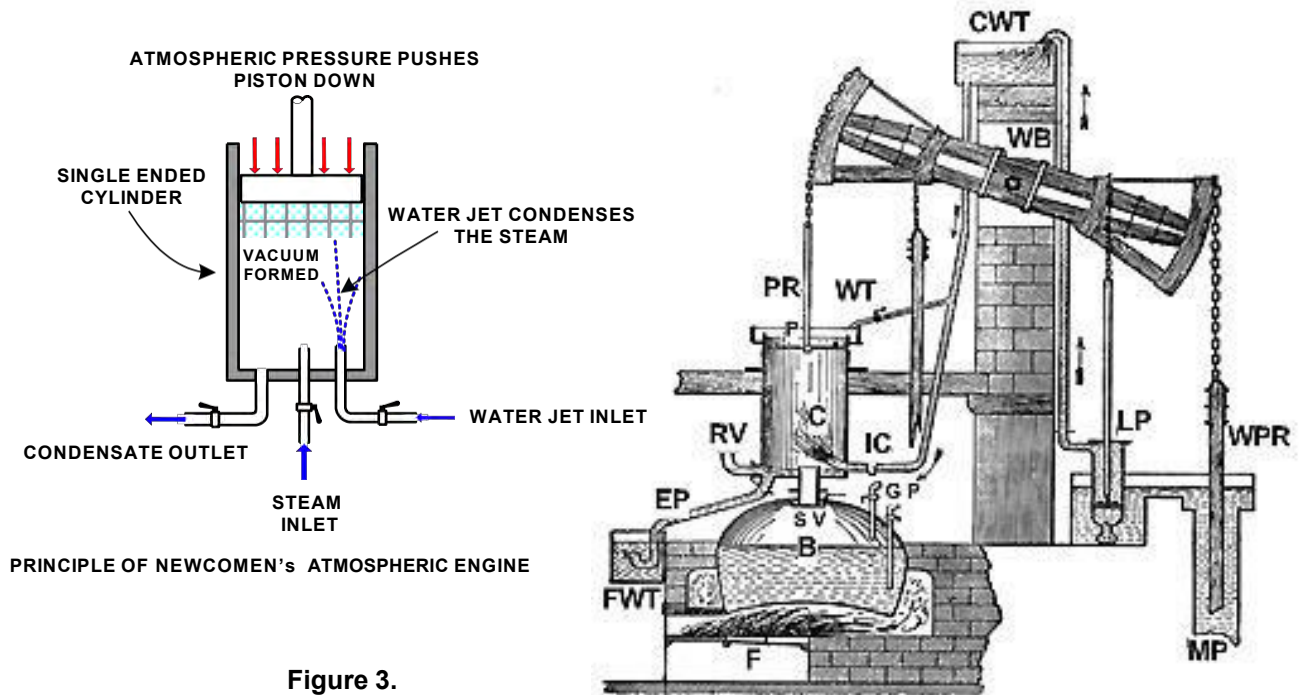

Figure 3.

As already stated Newcomen took inspiration from Papin and experimented with engines which had a piston inside a cylinder. So the principle on which the engine works is that condensing steam in a closed chamber creates a vacuum. But instead of using the vacuum to suck up the water the atmospheric pressure pushed the piston down into the cylinder (see diag. of Principle). To utilise this power Newcomen designed a large wooden beam pivoted about its middle, and a length of chain connected one end of the beam to the piston rod. The other end of the beam was connected to the mine water pump & rods.

Figure 3. shows the layout of an early Newcomen engine. As the piston **P** moves upward steam from the boiler **B** enters the cylinder **C**. At the top of the stroke the steam valve **SV** is shut and the valve **IC** to the water jet inlet is opened. The ensuing jet of water rapidly condenses the steam causing a vacuum to form under the piston **P**. Atmospheric pressure acting on the upper surface of the piston forces it down, pulling the beam **WB** with it. Consequently, at the other end of the beam the pumping rod **WPR** is raising water via the mine pump **MP**. The injection valve **IC** is then closed and the weight of the pumping rods **WPR** cause the beam **WB** to rock in the opposite direction thus lifting the piston **P** to the top of the cylinder **C**. Another cycle of pumping then begins. Condensed steam and injection water is ejected through a flap valve on the eduction pipe (**EP**) into the boiler feed tank **FWT** so making it hot.

We should note that in the early days of these engines the valves were manually controlled. If we look to the model in the display case we can see a number of clever linkages to operate them automatically.

### After Newcomen

The Newcomen engine reigned supreme for about seventy years after its inception. It spread gradually to more and more areas of Britain and mainland Europe. At first brass cylinders had been used but these were expensive and limited in size. New iron casting techniques pioneered by the Coalbrookdale Foundry Co., in the 1720s allowed bigger and bigger cylinders to be used, up to about 1.8m diameter by the 1760s.

Experience gradually led to better construction & minor refinements in layout. The engines mechanical details were much improved by John Smeaton, who built many large engines of this type in the early 1770s. By 1775 about 600 Newcomen engines were built, although many of these had worn out before then, been abandoned, or replaced. It is now estimated that by the close of the 18<sup>th</sup> century ~1454 Newcomen type engines had been constructed throughout the world.

The Newcomen Engine was by no means an efficient machine, although it was probably as complicated as engineering manufacture & materials techniques of the early eighteenth century would allow. Considerable heat energy was lost when condensing the steam, as this cooled the cylinder. This did not matter unduly at a colliery, where small coal (slack) was available, but significantly increased the mining costs where coal was not readily available, as in Cornwall. Another step in engine design needed to come, but this had to wait for the great James Watt and his separate condenser.

### Display Case 2.

#### James Watts Engine.



Watt (1736-1819), was a mathematical-instrument maker at the University of Glasgow. His introduction to the steam engine was when he was asked by Prof John Anderson during 1763-4 to repair a model of a Newcomen engine used for instruction of the Natural Philosophy class. He was struck with its enormous consumption of steam and began a series of improvements which finally rendered the steam-engine universally applicable. He analyzed the model engine scientifically. He studied the physical processes involved and, where necessary, carried out independent experiments such as those which led him to the rediscovery of the latent heat of steam, to the relation between pressure and boiling temperature, & to the pressure-volume relations for steam.

With these discoveries alone he would have made his mark as a natural philosopher of unusual talent. However, Watt had available as friends and consultants two of the best scientific minds of the age, Joseph Black (discoverer of latent heat of water) and John Robison, who not only encouraged him but lent him money to support his experiments.

Watt's most important improvement on Newcomen's machine was the addition of the separate condenser in 1765. Figure.4 illustrates such an apparatus. Instead of effecting the condensation, as in previous engines in the cylinder itself, there was placed under it an hermetically-closed iron box into which the steam from the cylinder was introduced and then condensed by an injected spray of cold water. But as the injected water along with the condensed steam would in a short time entirely fill the box, a pump **AP** (seen on the right in fig.4) was connected with it, by means of which the water and also the air contained in it could be constantly sucked up and removed. This pump is therefore called the "air- pump."

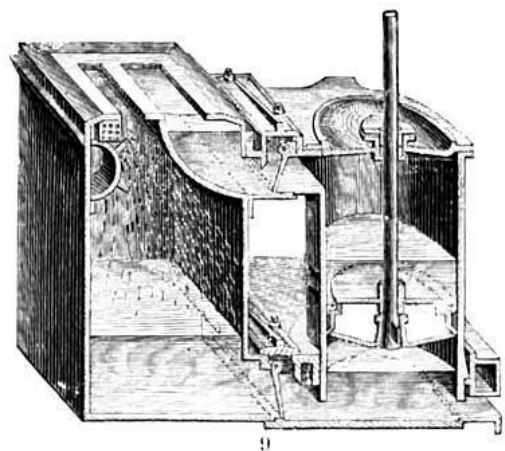

Figure 1.

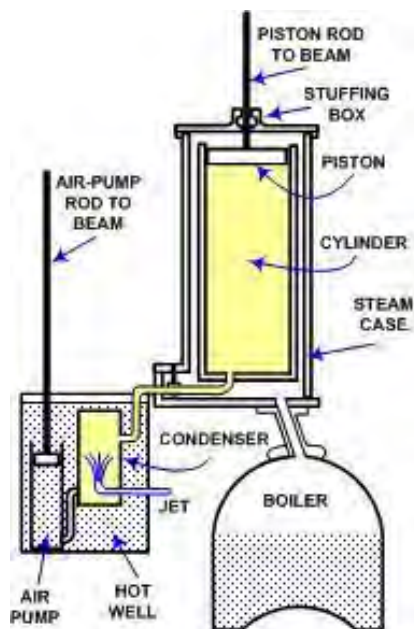

Figure 5 Schematic

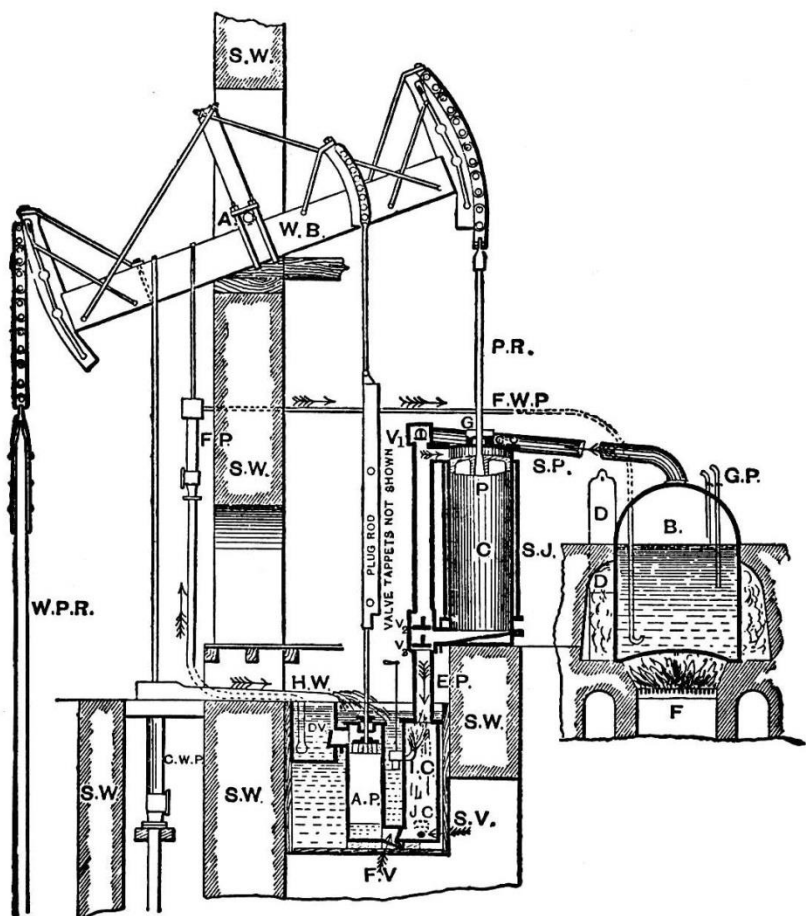

Figure 6.

Watt's Single Acting Engine 1769							
<b>F</b>	furnace	<b>WB</b>	wooden beam	<b>V<sub>2</sub></b>	equilibrium valve	<b>AP</b>	air pump
<b>D</b>	damper	<b>V<sub>3</sub></b>	exhaust valve	<b>A</b>	axis	<b>SV</b>	snifting valve
<b>B</b>	Boiler	<b>C</b>	cylinder	<b>WPR</b>	weighted pump rod*	<b>FV</b>	foot valve
<b>FWP</b>	feed water pipe	<b>SJ</b>	steam jacket	<b>EP</b>	exhaust valve	<b>DV</b>	delivery valve
<b>GP</b>	gauge pipes	<b>CC</b>	cyl cover	<b>JC</b>	jet condenser	<b>HW</b>	hot well
<b>SP</b>	steam pipe	<b>P</b>	piston	<b>IC</b>	injection cock	<b>FP</b>	feed pump
<b>V<sub>1</sub></b>	steam valve	<b>PR</b>	piston rod	<b>CWP</b>	cold water pump	<b>SW</b>	stone work

\* Weighted pump rod extends to bottom of mine

Watt's other improvements consisted in lagging the boiler, pipes, and cylinder with thermal insulating layers, and much later, in making the engine double-acting by closing the cylinder at the top and passing the piston-rod through a steam-tight stuffing-box. He used oil and tallow for lubricating the piston instead of water, which caused excessive cylinder-condensation. Technological improvements greatly improved the boring of engine cylinders & so yielded engines of much greater fuel efficiency. This enabled Watt and his partner Matthew Boulton to collect substantial royalties based on the fuel saved.

In 1774 he produced a beam-engine (Figure 6) in which the steam passed above the piston **P** and depressed it, raising the weighted pump-rods **WPR**, the lower end of the cylinder being in communication with a separate condenser (shown surrounding **AP**); then a valve **V<sub>1</sub>** was opened, allowing the steam

which was above the piston to flow beneath the piston, which was raised by the weight of the pump-rod. The "air-pump" **AP** relieved the condenser of air and of an excess of water, see Figure 5.

In 1781 (in order to avoid the payment of royalty upon the crank, which was patented) he employed the *sun-and-planet* movement, to produce a rotary from a reciprocating motion, and added a fly-wheel and a shaft, so that his engine could drive machinery. You may note the model in display case 2 has a rod & lever system and a fly wheel, to produce rotary motion. In 1782 he patented the use of the expansion of steam—the application of steam on each side of the piston alternately, the opposite side being in communication with the condenser—the double or coupled engine, and the use of a rack upon the piston-rod, working upon a sector on the beam, to give perfect straight-line motion to the rod. For guiding the piston-rod in a straight line Watt also provided the "parallel motion" linkage.

Watt kept up an active interest in science throughout his life. He was a lively member of the Lunar Society and a Fellow of the Royal Society and was in contact with the leading scientific minds of Europe.

### The Maudslay Engine:



Henry Maudslay (1771-1831) was initially more noted as a manufacturer and a machine designer, being the originator of the screw cutting lathe, the slide rest for lathes and other machine tools. He is also the creator of the world's first micrometer, which had a precision of  $3\mu\text{m}$ .

His interest in precision manufacturing and the creation of interchangeable 'standard parts' ranks him along with Joseph Bramah and Joseph Whitworth.

By 1810 Maudslay was employing eighty workers and he opened large premises in Lambeth. Maudslay recruited a promising young Admiralty draughtsman, Joshua Field, who because of his talents, became a partner in the firm. The company later became Maudslay, Sons & Field when Maudslay's sons became partners.

The Lambeth works began to specialize in the production of marine steam engines. These ship's engines were of a side-lever design, in which a beam was mounted alongside the cylinder. This saved on height in the cramped engine rooms of steamers.

He also developed the 'Table Top' engine, for use in manufacturing, so called because piston & cylinder sat on a large cast iron plate. Maudslay adopted a space saving measure with this engine and so the beam is absent.

These engines were simple condensing ones and were in most thermodynamic ways similar to the previously shown Watt engine. The elements of the engine are, where possible, labelled with the same nomenclature as the Watt engine.

In the Table Top engine the cylinder sits on a cast iron plate, or table. From a cross head fixed to the top of the piston rod and which is constrained to move vertically by means of a guide, two rods **R** proceed (one on each side of the cylinder) to turn the crank which is situated below the cylinder. The air pump **AP**, feed pump and cold water pump **CWP** are driven by levers which get their actuation from the crank. The steam valve **V<sub>1</sub>** gets its motion from an eccentric shaft.

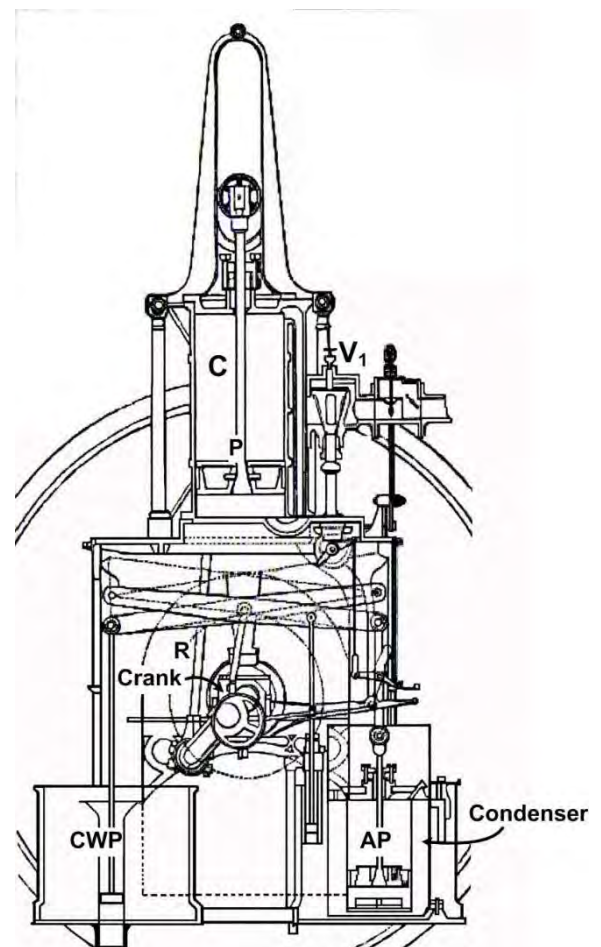

The firm later went on to produce large marine engines, notably for Brunel's SS Great Western & for ships of the Royal Navy. Maudslay's was one of the most important British engineering manufactories of the 19<sup>th</sup> century, finally closing in 1904.

### An Oscillating Engine:

These simple engine types became very common in the early 1800s and powered many smaller manufactories. They were of either vertical or horizontal design and the parts are much simplified. This greatly aided 'in-house' service and repair, which in no small way added to their popularity.

The cylinder vibrates on an axis either at top, bottom or middle. At top if vibrating in a vertical plane but at bottom or middle if horizontally mounted. By this arrangement the rectilinear motion of the piston is made to accommodate itself to the circular motion of the crank. This enables the piston rod to be connected at once with the crank without the intervention of a connecting rod thus securing the advantages of direct action. The valves are worked in one of two ways, either by eccentrics and levers (as in our example), or by the action of the cylinder itself as it is made to open and shut them thus simplifying the arrangements to a great degree.

We should note that in the case model a simple rotary type valve is operated by the lever mechanism.

Interestingly, James Watt constructed a model of this form of engine.

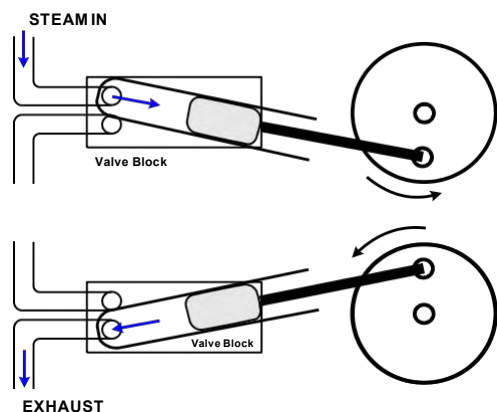

Figure 7. Rocking cylinder operates valves.

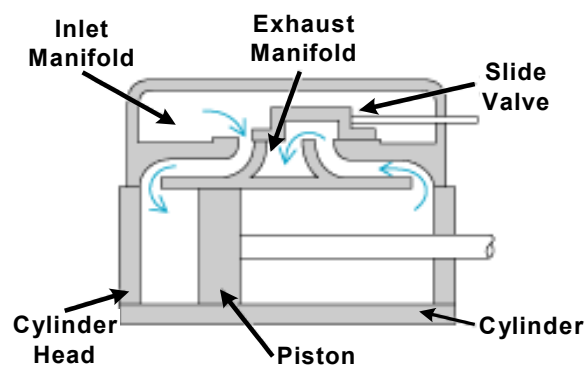

Figure 8. A typical simple slide valve

### PYRACMON MODEL.

In the year 1847 the GWR 0-6-0 goods engine "PYRACMON" was constructed, steaming out of the Swindon works in the November of that year. It is either the eighteenth, nineteenth, or twentieth engine to be manufactured there. The Company records show that two IRON DUKE Class engines, PASHA and SULTAN, were also built in November, but precise days are not noted. Gooch's diary for late 1847 is no help in the matter; some three pages of entries make no mention of any engines.

From the model, and what little information there is, we may make some general observations about PYRACMON and its Class. Technically the engine is a derivative of the PREMIER or AJAX Class and thus owes much to Stephenson's designs, a principal innovation being the removal of the "Gothic or Haystack" firebox and its replacement with a round topped one. The engine is domeless, steam was taken from a long perforated pipe (Hawthorn's patent) which extended along the whole length of the inside of the boiler. Steam entered through a large number of slits in the top of the pipe and passed through the regulator to the cylinders.

Pyracmon's total heating surface is about 1,373 sq ft (~127m<sup>2</sup>) with a grate area of 18.4 sq ft (~1.7m<sup>2</sup>); it had a boiler pressure of 115 psi (792kPa). The cylinders remained similar to the PREMIER. The firebox is surmounted by a neat cylindrical cover with a square base within which is situated the safety valve. This is characteristic of Gooch's engines from that period onwards. The boiler section and fire

box exterior were insulated with a layer of No.3 hairfelt and were lagged with oak planking. The woodwork was finished with three coats of mineral paint and a top coat of copal varnish.

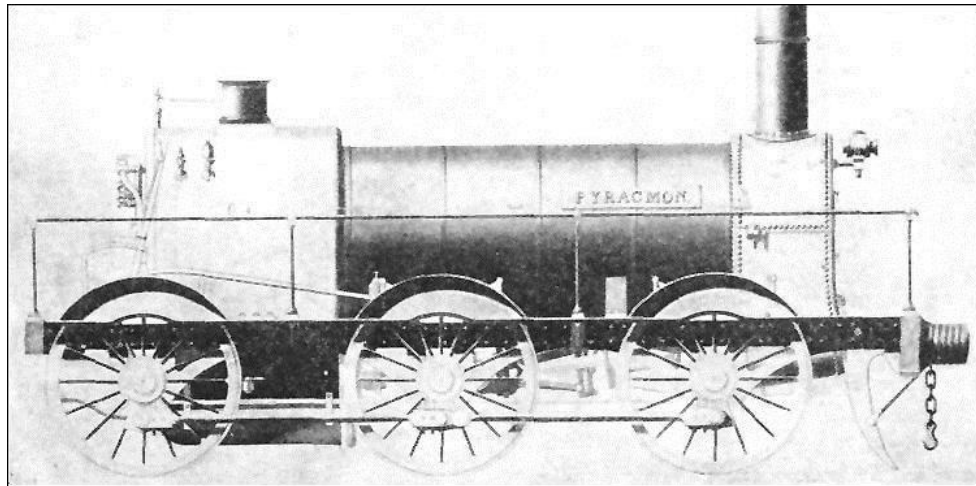

**Figure 9. Gooch's PYRACMON (source undefined)**

The working gear of the PYRACMON model was thought to be irretrievably lost. However, subsequently it was found to be in the tender care of the Steam Museum Straffan Co., Kildare (<http://www.steam-museum.com/>). Illustrations in Dempsey's treatise of 1859 show a half plan and elevation of the mechanisms and pistons of the original engine, Figure 10, here we may plainly see that the link motion is Gooch's stationary link design, with the "Link" (a) curved towards the cylinder and suspended by a further link from the engine casing. Compared with the Stephenson gear, this arrangement has more joints but results in an improved valve motion, whereby the "lead" is constant for all positions of the radius rod (b). Gooch's linkage was used on all GWR engines until the era of Armstrong as superintendent. The properties of both Gooch's and Stephenson's linkages are clearly described in Hurst<sup>\*\*\*\*\*</sup>.

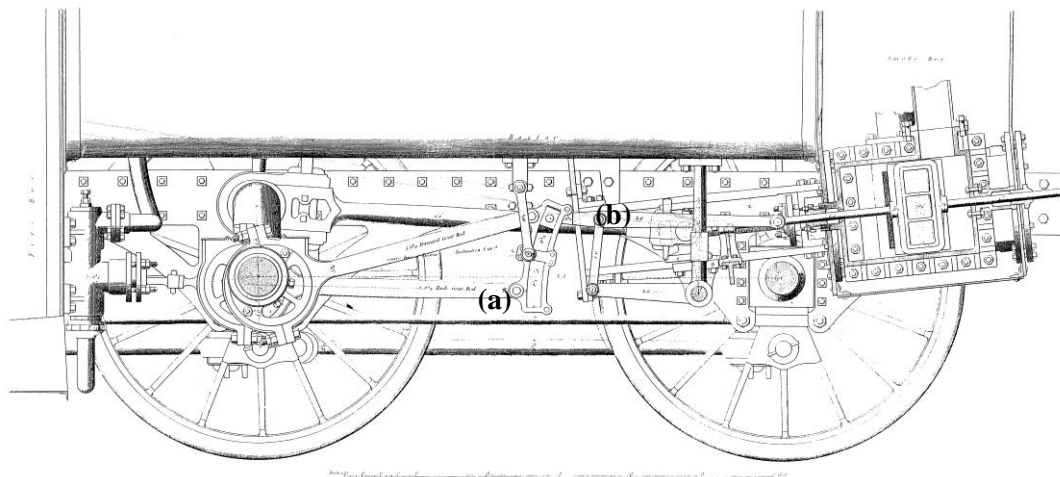

**Figure 10. Gooch's Link Motion for PYRACMON**

PYRACMON, (tempered in the flames) gave her name to the PYRACMON or ALLIGATOR Class of 7 engines. These others were named STEROPES (the giver of lightning to Zeus), CALIBAN, BEHEMOTH, MAMMOTH, ALLIGATOR and BACCHUS. Although BACCHUS is included she was different in that she was made from the parts of older engines.

\*\*\*\*\*  
C Hurst, 1902, "Valves and Valve Gearing: a practical text book." London Chas Griffin & Co. 1902.

At a later period the PYRACMON Class was subsumed into the next designed 0-6-0 CAESAR CLASS of engines and so even the name PYRACMON faded away. PYRACMON herself gave 25 years of service with little to note other than slight damage from a derailment Llanwern on 6<sup>th</sup> May 1857. After some 385,000 miles of travel, she ceased work in March 1872, and so came her end.

**Construction details of the Pyracmon Class:**

Loco 0-6-0 : The engine had a wheel base of 7ft-4ins (2.24m)+ 8ft-1ins(2.46m) with 5foot (1.52m) wheels.

Broad Gauge 7ft ¼ ins.(2.14m)

Inside Sandwich frames: Overall length 24ft (7.32m): Height tip of stack 14ft (4.27m):

Cylinders 16ins (0.4m)Ø x 24ins (0.61m) Stroke:

Domeless boiler: raised firebox casing – Barrel 10ft 6ins x 4ft 3ins (3.2m x 1.3m), 219- 2ins (56mm) tubes:

Firebox Casing 4ft 11ins x 5ft 3½ins (1.5m x 1.6m): Tube heating surface 1134.40sq ft 105m<sup>2</sup>):

Firebox 121.33sq ft (11.3m<sup>2</sup>): Total 1255.73sq ft (116m<sup>2</sup>) : Pressure 115lbs (792kPa)

**PARSONS TURBO GENERATOR:** See separate notes.

**End Note:**

Here we must end. I am all too aware that I have not described double acting, multi expansion, McNaughted, or compounded engines and also that I have left out many important technological advances that occurred. However, I hope the foregoing enhances your viewing of the models and makes the links between science and technology clear.

Perhaps the last words should be given to Milton Kerker;

*“The contributions of Carnot and Watt to science serve to emphasize the dynamic nature of the relation between science and technology. Carnot’s contribution led to further scientific developments, which in turn provided the basis for whole new technologies. The connections between science and steam technology were neither simple nor static. But one thing is certain. Steam engine technology cannot be considered apart from the body of science.”*†††††

*Garrett Lyons  
March 2013*

**Acknowledgements:**

I have liberally used the work and words of others; as this is not a scientific text I have not acknowledged all by name. But I offer my gratitude to them for their useful texts and papers. To Dr., Ron Cox T.C.D., my thanks for assistance with dating some of the models, my thanks also to friends, Christian Welz for information on ‘stangenkunst’ and to Ciaran Simms; who made me write this.

---

††††† Kerker M., (1961) “*Science and the Steam Engine*”. Technology & Culture. Vol 2, No 4, pp381-90



**Appendix I: Memorial to the Board proposing a School of Civil Engineering and Architecture.  
Trinity College - April 3rd 1841**

The undersigned respectfully submit for the consideration of the Board the following statement relative to the establishment of the School of Civil Engineering and Architecture in the University.

Until within the last few years the system of training in this country for the important profession of Civil Engineering and Architecture has been similar to that adopted in the purely practical Arts; namely by Apprenticeship. The results of this system have been - first that a great barrier in the shape of experience has hitherto stood before entrance into these professions - and secondly that the requirements of the Civil Engineer and Architect have been (generally speaking) of a most practical kind and that few even of the highest ornaments of their profession in Britain possess competent knowledge of the scientific principles upon which the rules of their Arts are based.

The result of this state of things is sufficiently evident in comparing the position of these professions in England and on the Continent. While, in this country enormous expenditure of capital in public works has forced into existence a sufficiency of practical skills, it is yet evident that the practices thus developed consist for the most part in a sensible imitation of the efforts of a few original minds, whose genius had overcome the difficulties they had to encounter; and that there is a great deficiency in that theoretical knowledge which is necessary in meeting new emergencies or in giving maturity and perfection to the creations of original thought.

For these reasons we conceive it to be of the utmost importance to the public that part, at least, of the training for these professions should be conducted by the Universities and it is needless to profess the claims which they profess upon the Universities both on the grounds of their great national importance, and on account of the close connection of the knowledge which they require with the science already taught within the walls of these institutions.

This necessity has been clearly felt elsewhere, and schools of Practical Engineering and Architecture are already in existence, in connection with King's College London, and with the University of Durham.

The undersigned earnestly entreat the Board to consider the expediency of establishing such a school in connection with this University.

The subjects requisite to be taught in such a school are the principles of Mathematics, Mechanics, Chemistry and Geology and the application of these principles to the Arts of Construction; practical Engineering and Architecture. It is believed that these subjects may be effectively taught by two Professors, in addition to those already existing in the University — namely a Professor of Chemistry and Geology in their relation to the Arts of Construction, and a Professor of practical Engineering and Architecture. It is probable that a moderate salary, together with a portion of the fees derived from engineering students, would be sufficient to obtain the services of men of high character in these branches of Science; and that the School of Engineering would, to a large extent, defray its own expenses.

The undersigned beg to enclose some printed documents connected with the Schools of Engineering in Kings College London and the University of Durham; and they take the liberty of adding for the consideration of the Board (in case they should approve of the principle), an outline of the plan for the establishment of such a school in the University of Dublin

**H.Llyod, Prof. Nat Philos. J. McCullagh, Prof. of Maths. Thos Luby..**

We may contrast the above with some words from 'that unassailable demigod of Victorian Engineering', Isambard Kingdom Brunel. Who despite having a distinguished father that studied engineering in the Continental manner and having himself experienced this mode of learning for some years, wrote the following to a young man who wished to train as an engineer. *"I must strongly caution you against studying practical mechanics among French authors - take them for abstract science and study their statics dynamics geometry &c to your hearts content but never even read any of their works on mechanics any more than you would search their modern authors for religious principles. A few hours spent in a blacksmiths and wheelwrights' shop will teach you more practical mechanics - read English books for practice.- There is little enough to be learned in them but you will not have to unlearn that little"*<sup>+++</sup>

<sup>+++</sup> Brunel I.K, *Private letter Books Vol 12*. Dec 1848, Archives Bristol Univ.

## A (very) Rough History of Thermodynamics.



**Nicholas Léonard Sadi Carnot** was born 1 June 1796 in the palace of Luxembourg in Paris, where his father, Lazare Nicholas Marguerite, then lived as a member of the Directory. The elder Carnot had already established his niche in the history of science when he published a number of important works in mathematics & engineering. For a time, he served as Napoleon's minister of war. Sadi prepared to follow in his father's footsteps by entering the Ecole Polytechnique in 1812. On graduation in 1814 he was commissioned in the engineer corps & in 1819 gained an appointment to the general staff corps in Paris.

In 1828, he devoted him-self completely to his intellectual and technical pursuits until his premature death from cholera on 24 August 1832.<sup>7</sup>

In the year 1824, in Paris, Sadi Carnot published his '*Reflections on the Motive Power of Heat*' which was destined to lay the foundations of thermodynamics and to distinguish him as one of the very great scientific thinkers. Although he was an engineer and wrote primarily for engineers, his work was almost completely neglected by them. A quarter of a century later it was exhumed by the physicists, Kelvin and Clausius, and it then diffused into engineering theory and practice.

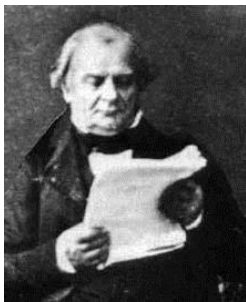

**Benoit-Pierre-Emile Clapeyron** was born in Paris on 26 February 1799 and died there on 28 January 1864. He graduated from the Ecole Polytechnique in 1818 and then attended the Ecole de Mines. In 1836, he traveled to England to order some locomotives that would negotiate a particularly long continuous grade along the Saint-Germain line. When Robert Stephenson declined to undertake the commission because of its difficulty, the machines were built in the shops of Sharp and Roberts, according to the designs of Clapeyron."<sup>8</sup>

He was elected to the Academy of Sciences in 1848, replacing Cauchy, and served on numerous committees of the Academy. Clapeyron had a continuing interest in steam engine design and theory throughout his career. Ten years had passed with Carnot's work finding hardly an echo, until 1834 when Clapeyron published a paper in which he detailed the exposition of Carnot's verbal analysis in the symbolism of the calculus and he represented the Carnot cycle graphically by means of the Watt indicator diagram, familiar to engineers. The paper also appeared in translation in England and Germany, so that despite the rarity of the original, Carnot's work was generally available and associated with the name of Clapeyron who was widely recognized as a leading steam engine engineer. However, not only was Clapeyron's original paper ignored by the other engineers, but he himself made only one passing reference to it until the work of Kelvin and Clausius made its true significance generally known.

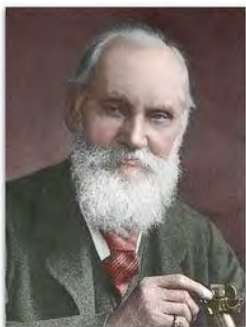

**William Thomson (Lord Kelvin)** was born in Ireland in 1824. In 1830 Williams's mother died and the family moved to Scotland where William's father, James had been appointed Professor of Mathematics at Glasgow University. Four years later, in 1832, William, age 10, and his brother James, age 12, began their studies at Glasgow University.

William became notable for his role in the formation of the Glasgow [school](#) of thermodynamics and for being the third person to publish a paper on Sadi Carnot's 1824 heat engine theories, specifically his "On an Absolute Thermometric Scale", and for his behind the scenes efforts in helping to bring together the science of thermodynamics, through his association with Peter Tait, James Maxwell, Rudolph Clausis, and William Rankine.

In 1840, Thomson came across Edinburgh mathematics professor Philip Kelland's 1837 *Theory of Heat*,<sup>1</sup> in which it was claimed that Fourier<sup>2</sup> was mostly wrong. In comparing the two Thomson told his father, "Fourier is right, and Kelland is wrong."

Beginning in about 1843, Thomson developed an interest in the efficiency of heat engines and the works of Carnot through discussions on the subject with his older brother James Thomson. In 1848, William developed the Kelvin scale of absolute temperature measurement based on Carnot's theories and in 1849 coined the term "thermo-dynamic". In 1854 defined "thermodynamics" as a subject<sup>3</sup> and in 1852, he gave verbal descriptions of the Second Law of Thermodynamics that there is a universal tendency in nature to the dissipation of energy. He christened the now-famous term "Maxwell's demon" in 1874.

**William Rankine** was one of the core thinkers who, between 1845-1865, brought the newly forming science of thermo-dynamics to maturity, and is noted for his competition as it were with Rudolf Clausius, in their similar, but slightly different formulations of thermodynamics (Clausius's version is the one we now use). Rankine notably introduced the term "**potential energy**" in 1853. In his 1854 article "On the Geometrical Representation of Expansive Action of Heat, and the theory of Thermo-dynamic Engines", Rankine describes James Watt's '*indicator-diagram*', Emile Clapeyron's '*diagrams of energy*', and discusses '*isothermal curves*' and '*curves of no transmission of heat*'.



Rankine's chapter on thermodynamics, according to Maxwell, titled "Principles of Thermodynamics" - in his 1859 book *A Manual of the Steam Engine and Other Prime Movers*, was the first published treatise on the subject of thermodynamics, and is the only expression of his views addressed directly to students. In the opening section of this chapter, in reference to the results of the mechanical equivalent of heat, Rankine defines thermodynamics as such:

*"It is a matter of ordinary observation, that heat, by expanding bodies, is a source of mechanical energy; and conversely, that mechanical energy, being expended either in compressing bodies, or in friction, is a source of heat. The reduction of the laws according to which such phenomena take place, to a physical theory, or connected system of principles, constitutes what is called the science of thermodynamics."*

So we see the development of this, most important, engineering subject in the years after the opening of the Engineering School TCD. Also we may note the interweaving of the work of engineers with that of physicists to develop the topic. This negates the writings of many authors who attribute the development and advancement of the steam engine to the somewhat mystical work of '*rude mechanicals*'.

I believe it also reinforces my argument that the models used in this early phase of instruction in engineering were a vital factor in concentrating the student's minds on the link between science and technology. They were no less valuable than our software systems in analysis and simulation are today.

1. Kelland, P. (1837). *Theory of Heat*. Cambridge.
2. Fourier, J. (1822). *Analytical Theory of Heat (Théorie Analytique de la Chaleur)*. Cambridge.
3. Thomson, W. (1848). "On an Absolute Thermometric Scale Founded on Carnot's Theory of the Motive Power of Heat", *Phil. Mag.*, Oct. 1848. (pp. 100-06),