

Evolution of the Parsons Land Steam Turbine

The 2019 Parsons Memorial Lecture

Geoff Horseman

*Chief Turbine Engineer, Siemens plc, CA Parsons Works,
Shields Road, Newcastle Upon Tyne, NE6 2YL, UK*



Sir Charles Parsons

Introduction

In 1884, Sir Charles Parsons developed the World's first truly powerful steam turbine – a new type of engine which had the potential to supersede the ubiquitous reciprocating steam engine in terms of maximum power output, efficiency, reliability and the freedom to provide any amount of power anywhere. At the same time, he developed a type of generator which could withstand the high speeds used by the turbine. This enabled him to design and build the World's first steam turbine-generator, the machine type which would make large scale power generation possible so that electricity would become both affordable and available to everyone. Ten years after his first steam turbine, he developed the World's first successful turbine driven ship, *Turbinia*, and subsequently saw steam turbines become the dominant engine type for ships which needed high power and/or high speed.

The story of Sir Charles' companies and the machines which were built has been told only up until 1931, the year Sir Charles passed away. Key references are Richardson 1911 [1], Appleyard 1933 [2], RH Parsons 1936 [3], and Scaife 2000 [4]. The story has never been told in its entirety anywhere. Work is now in progress to document the history as completely as possible. This paper is an extract from this work and focuses on the development of the Parsons land steam turbine from 1884 until 1997, when the parent company CA Parsons & Co Ltd became part of Siemens. By necessity, to achieve a reasonable paper size, only the most technically advanced machines will be covered here, although this means that the following pages still contain considerable information.

Parsons' first engines

From an early age, the young Charles Parsons wanted to develop a new type of engine which used pure rotary motion. In addition, as one of the main applications, he wanted to use this to drive an electrical generator directly without a belt drive. In the 1870s & 1880s, when he attempted his first designs, most electricity was generated using either reciprocating steam engines, which were inefficient and frequently unreliable, with many breaking down almost daily, or from water turbines which achieved high efficiencies, typically between 70 and 80% [2], but with power outputs limited by the available water supply.

While working for Kitsons of Leeds between 1881 and 1883, he came close to designing a direct drive rotary engine for electricity generation in the form of an epicycloidal steam engine. This was a motor with four pistons in a cruciform arrangement in which both the cylinder block and the crankshaft rotated, the casing turning at half the shaft speed. This engine had some commercial success, but it was not the ideal, pure rotary machine he desired. Also, while working at Kitsons around 1881, Charles developed a gas turbine to power torpedoes. In this case, rocket propellant was used to generate the gas flow which then impinged on some "paddles" attached to the propeller shaft ie he employed an impulse turbine. Again, this was commercially successful with many hundreds of turbine driven torpedoes being built, but Parsons did not take this further; rather he switched his attention to the steam turbine.

The invention of the steam turbine is usually credited to Hero of Alexandria, who lived between 10 and 70 AD. He made a device, fig.1a, in which steam entered a sphere via hollow support legs and emerged as jets of steam from two projecting arms. This was named the "aeolipile". The steam jets produced forces which caused the sphere to spin and this was used to impress worshippers in a temple, but it produced no useful work. In 1629, Branca sketched the first impulse turbine, fig.1b, in which a steam jet was shown impinging onto a wheel to turn it, but it's understood that this machine was never built.



Fig.1a Hero's aeolipile or reaction turbine, *left*, and fig.1b Branca's impulse turbine, *right*

In the 1700's and 1800's, these devices were well known and many hundreds of patents were raised for different types of steam turbine. For example, in the USA, Hero turbines with two spinning arms with a span of typically 2 feet 6 inches (0.76 m) were used to drive circular saws and cotton gins. Gustaf de Laval of course is famous for using a Hero turbine to spin cream separators, fig. 2.



Fig.2 De Laval's Hero turbine of 1883 used to drive cream separators. [3]

While there were many devices of this kind, in 1884 none of them were used to produce electricity and none produced high power outputs. Charles Parsons took on the challenge of developing a steam turbine for electricity generation and subsequently for mechanical drives and ship propulsion with the potential to produce high power outputs and high efficiency outperforming the best existing engines.

The first steam turbine-generator

On the 1st February 1884, at the age of 29, Charles joined the company Clarke, Chapman, Parsons & Co in Gateshead as a junior partner and Chief Electrical Engineer and by 23rd April, he had constructed and patented the World's first steam turbine-generator, figs. 3 and 4.

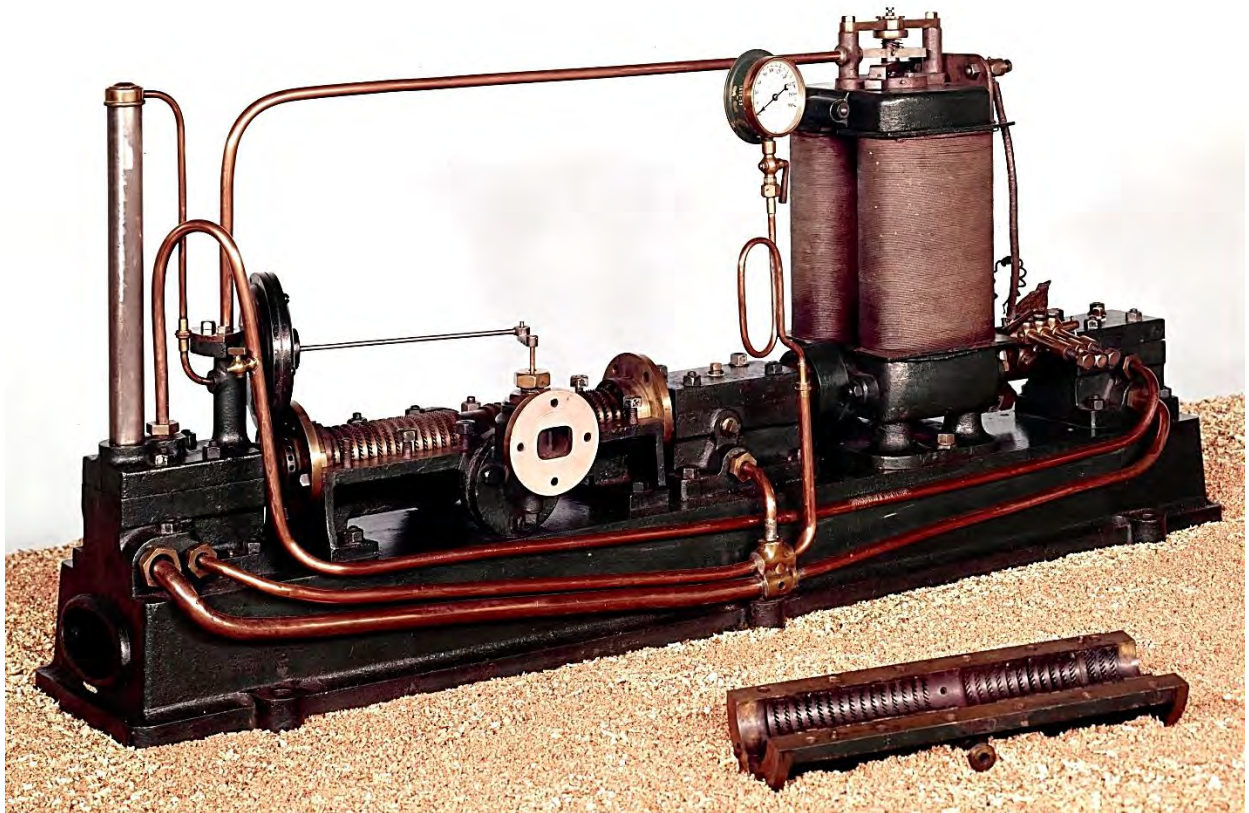

Fig.3 The World's first steam turbine-generator 7.5 kW at 18,000 revs/min 1884
[Courtesy: Science Museum, London]

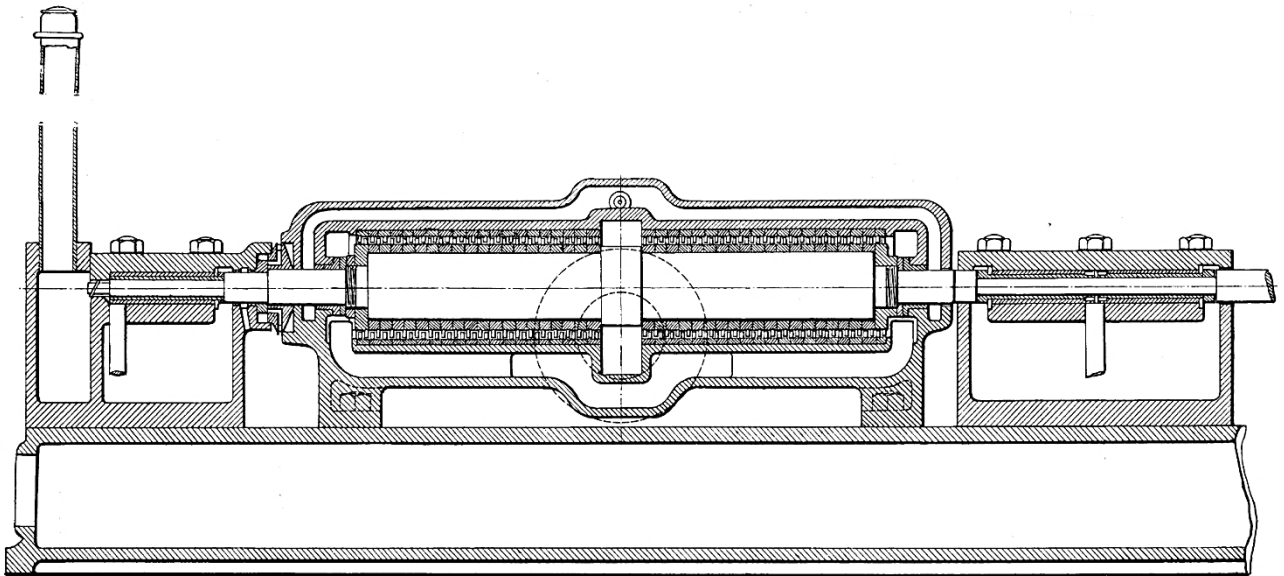

Fig.4 Cross-section through the turbine [3]

This machine used steam at 80 lbs/in² gauge (5.5 barg) saturated and discharged to atmosphere. The generator produced 7.5 kW at around 1000 volts. The steam entered at the centre and then passed through blading in both the right and left hand flows. This double flow arrangement cancelled out the axial end thrusts of the opposed bladepaths. The blades were formed as simple angled slots cut in the periphery of a series of brass discs mounted on the shaft and formed within the casing, fig. 5.

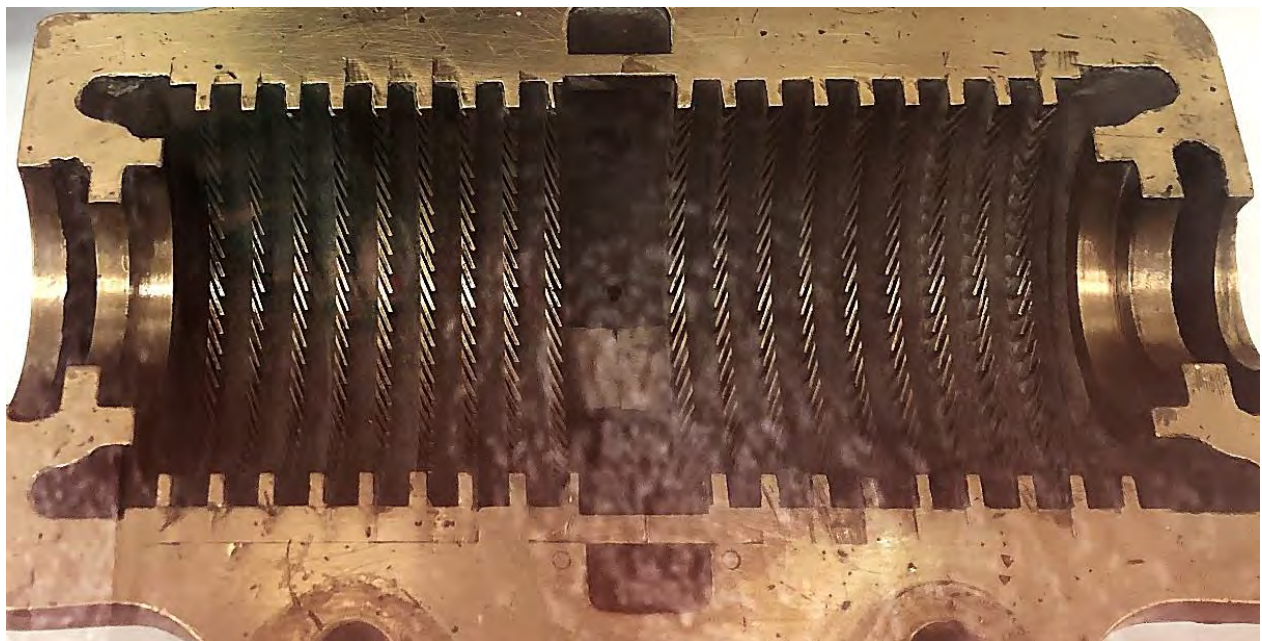

Fig.5 View of the blades created as simple 45° angled slots in a small, portable demonstration turbine similar to machine no.1.

This machine was a considerable challenge since at 18,000 revs/min, it ran 900 times faster than reciprocating steam engines of the day, which operated at typically 200 revs/min, and 15 times faster than the highest speed dynamos. This required the shaft and casings to be sufficiently strong, for a new type of bearing to be used (sleeve bearings surrounded by spring-loaded washers), a generator construction which could keep its conductors in place at high speed, a special governor to

control the inlet valves etc. Details are given in refs [1] and [3]. Parsons developed suitable designs very quickly and subsequently improved the designs in each generation of machine built.

The idea for the blading came from studying water turbines. These were well developed by the late 1800s and were very efficient. In 1833, Benoît Fourneyron had worked out how these worked mathematically and the findings had been applied successfully to water turbines by James Francis and others, fig.6. Charles Parsons learned of Francis' work, which had been published in 1855, and may have met him when he travelled to the USA in 1883.

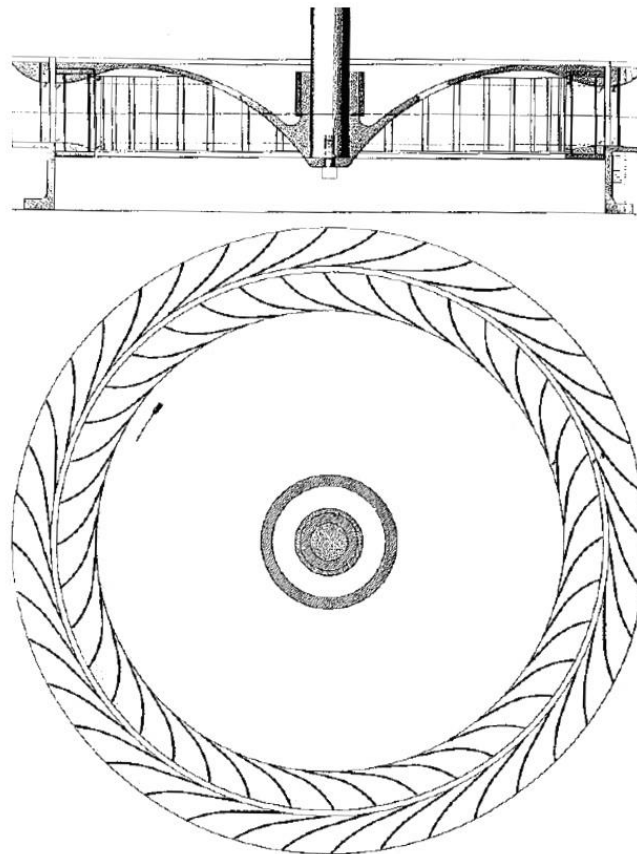

Fig.6 James Francis' first water turbine of 1855

In his first turbine of 1884, Parsons employed many stages of blading such that the expansion of steam was small in each stage and so was analogous to many “water wheels” in series. This was successful, although the average velocity ratio (ie blade speed divided by steam speed) was only around 0.56, far below optimum.

The first steam turbine-generator may be seen in the Science Museum in London.

Comparing machines of different power output and speed

In the following pages, we'll look at the progressive changes in turbine power and speed which followed. One of the principles which will be used is “dynamic scaling” also known as “dynamic equivalence”. This is a simple tool which may be used to compare machines running at different speeds to see which one pushed the limits of technology the most. As machines produced more power, this usually marked an upward move in technology. However, sometimes the speed of the machine was reduced to make the conditions less demanding. Dynamic scaling may be used to see which machine was more advanced.

For example, a 6 MW turbine running at 1,500 revs/min is technically more demanding than a 10 MW turbine running at 1,000 revs/min. How do we know this? We scale the 6 MW set up in size in proportion to speed squared to see what it would produce at 1,000 revs/min at the same stress & thermodynamic loading. The calculation is $6 \times \frac{(1500)^2}{(1000)^2} = 13.5 \text{ MW}$.

This means that a 6 MW set running at 1,500 revs/min operates effectively at the same stress level and thermodynamic load as a 13.5 MW set at 1,000 revs/min.

The basis of this comparison is given in Appendix A.

Turbine-generators produced by Clarke, Chapman & Parsons 1884 to 1889

The turbine-generators produced between 1884 and 1889 were numbered from 1 to 288. Excluding machines used for development purposes and un-named machines, 241 were turbine-generators manufactured for use by customers. Many of these still exist in museums around the World today.

William Clarke and Abel Chapman supplied equipment for ships and wanted to provide electric lighting, which was newly emerging in the 1870s and 80s. Parsons was engaged to develop the machines. As a consequence, the majority of the turbine-generators (TGs) in the first 5 years were made for ships.

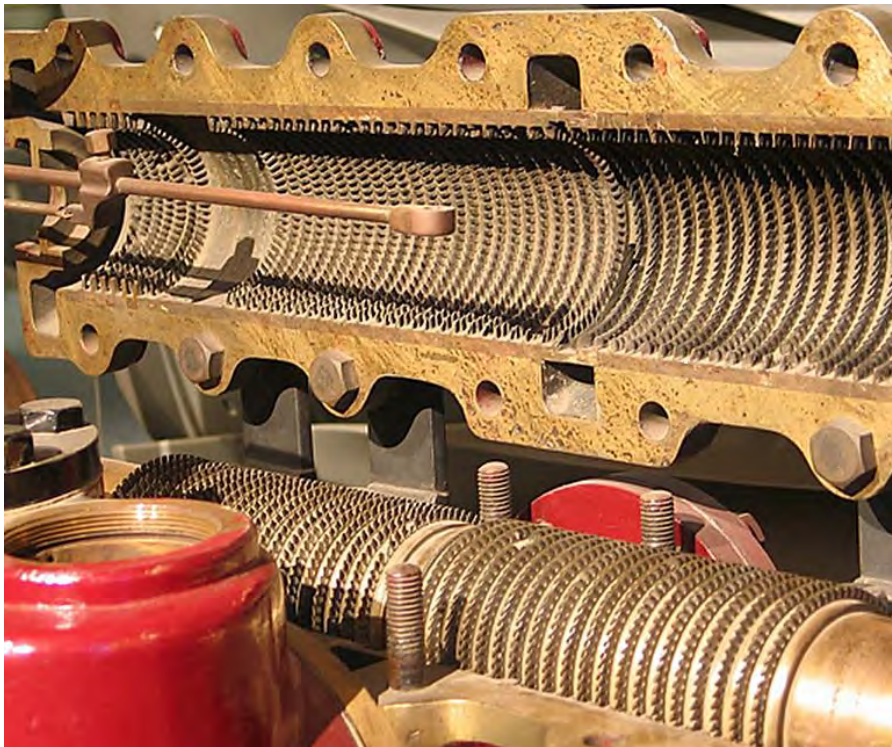

Fig.7 Machine no.4, a 2 kW turbine for the SS Earl Percy 1885 – the first “production” TG set
[Courtesy: Sheffield Industrial Museums Trust]

The first unit supplied to a customer was machine no.4 manufactured in 1885 for the SS Earl Percy. It produced 2 kW at 10,000 revs/min and was very similar to machine no.1. It came close to an early end since the ship sank in September 1888, but the TG set was removed before this occurred. It's presently preserved in the Kelham Island Museum in Sheffield, fig.7.

The first machines became known as “steam eaters” because in the 1880’s, they required around 27 kg/kWh of steam compared with about 18 kg/kWh for a good reciprocating steam engine. They sold because they were reliable, the output voltage was steady which extended lamp life (electric lamps were expensive), vibration & noise were low, maintenance was low (no oil in the steam, fewer operators), they did not require drive belts and they were lower in cost & compact in size compared with reciprocating engines. While reciprocating steam engines could break down almost daily, steam turbines did not and this provided a major advantage.

Many efforts were made to improve the efficiency of the machines. It was known that performance would improve if unit size increased and if blade shrouds were used. Unit sizes increased to 75 kW (a ten-fold increase over machine #1). Many types of shroud were tried but without effective labyrinth seals, they didn’t yet provide sufficient gain.

A major advance occurred with a 32 kW set built in 1888, fig.8, which employed:

- Curved blades, fig.9. These were made from rings of solid metal as before but the blades had an undercut groove on the inlet side. The overhung section was bent with pincers to curve the blade.
- The rotor diameter increased in steps towards each end to help increase the flow area.
- Blades were cut at different angles to increase the flow area.

Turbine efficiency improved by around 25%. This brought the steam consumption (typically 21 kg/kWh with steam at 6.3 barg) closer to reciprocating engines but the turbine was still inferior.

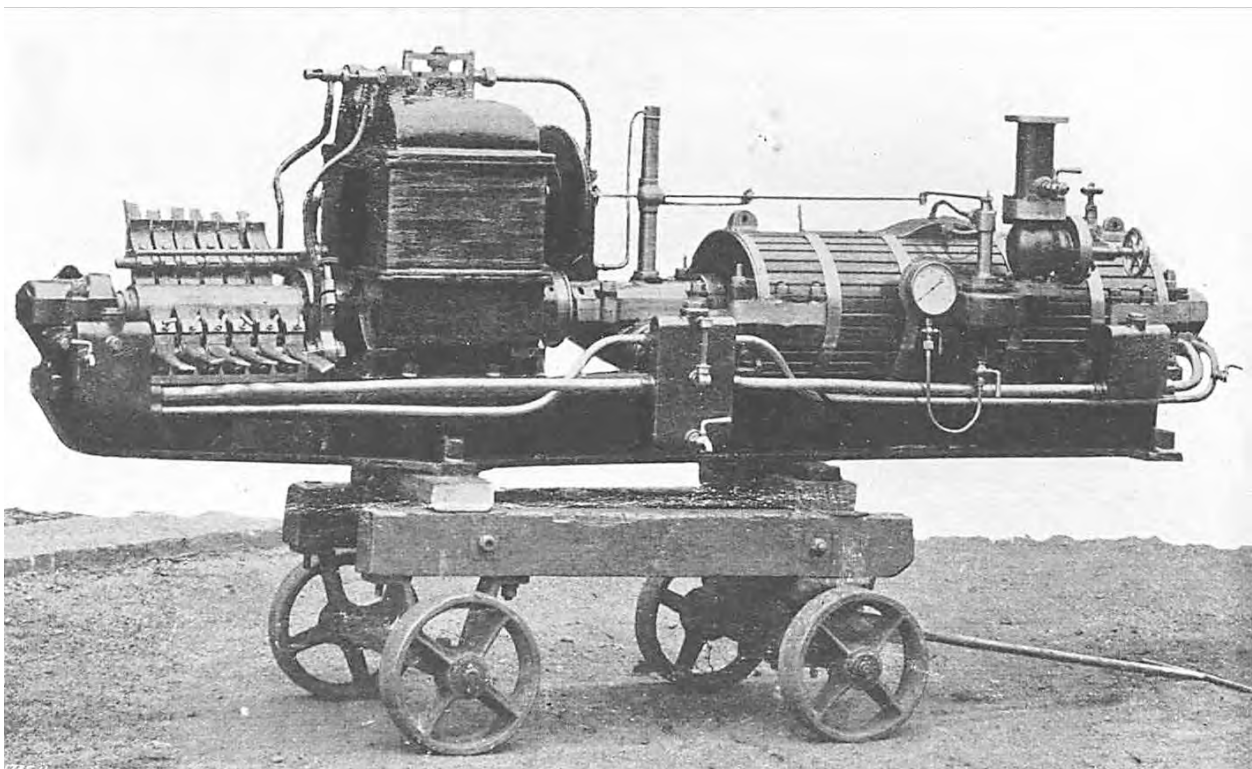

Fig.8 A 32 kW turbine-generator 1888 [3]

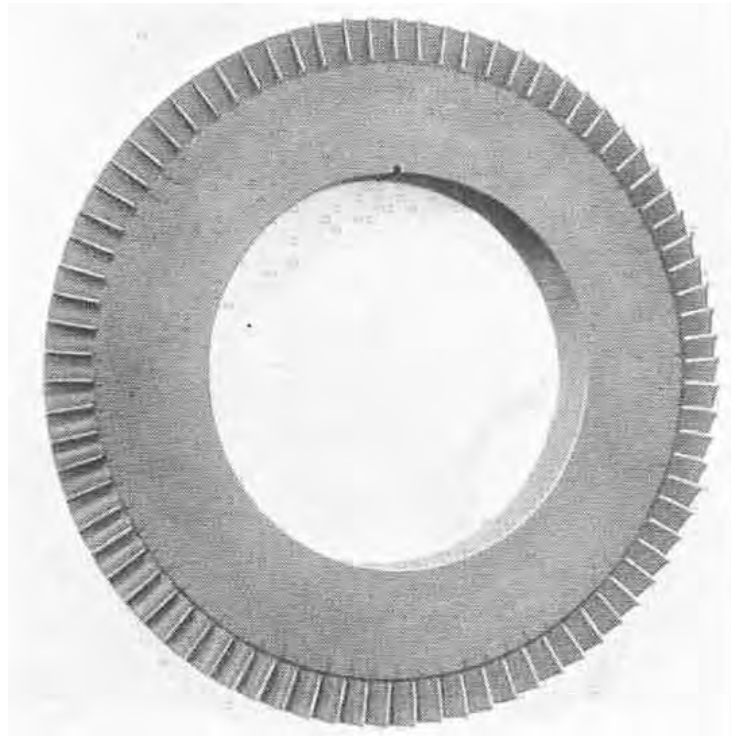

Fig.9 Curved blades from the 32 kW machine [3]

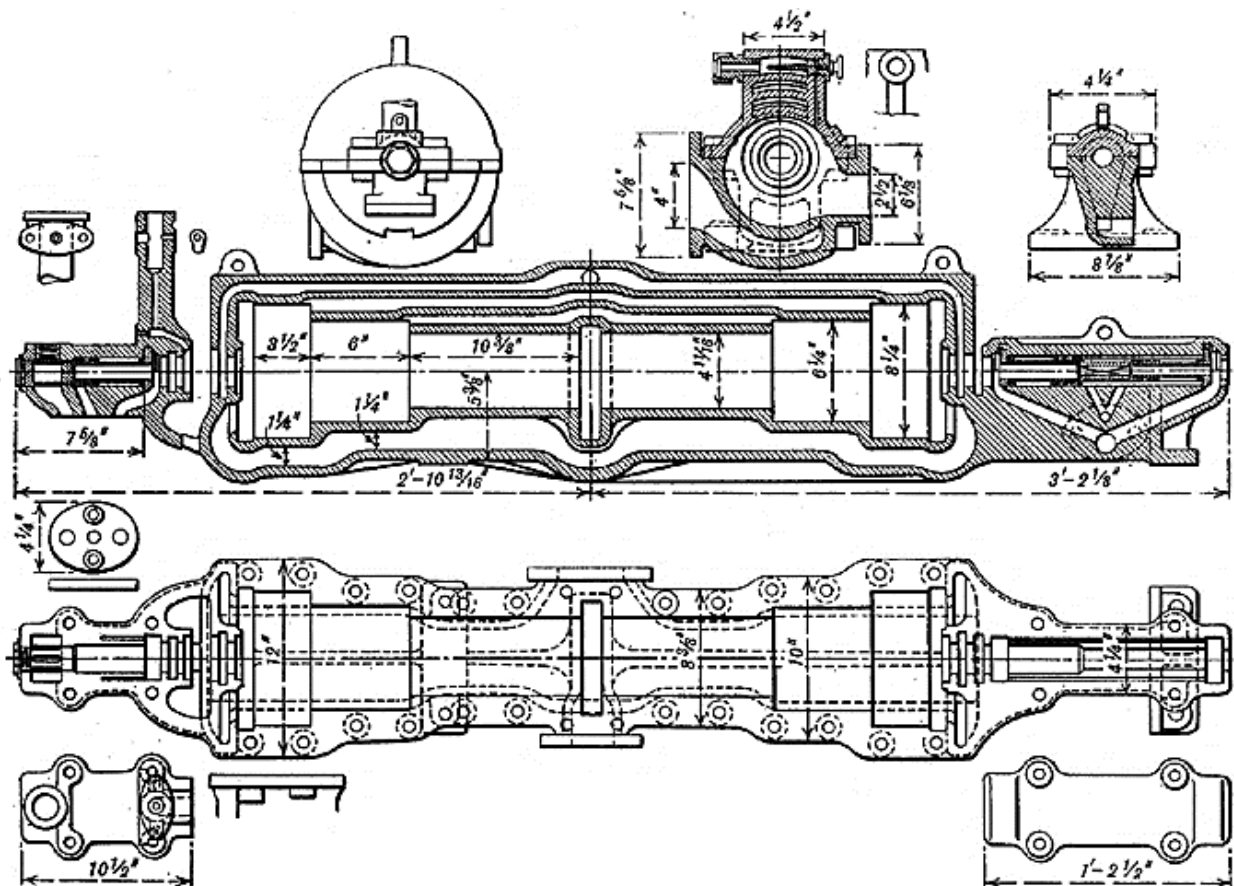

Fig.10 Cross-section through the casing of the 32 kW machine showing the internal passageways used to equalise the pressures acting on the right and left hand steps in rotor diameter. The exhaust steam was brought to a central outlet port, using the speed of this steam to suppress the pressure in the casing end glands to prevent steam from escaping. [3]

Parsons knew that the efficiency of turbines would increase if the machines were larger and in 1888, he produced the drawings for a 500 kW two cylinder turbine, but Clarke & Chapman didn't want to build it. This power output was too high for ships and so could be used only in land based power plants.

The prospect of supplying TGs for land based power stations was restricted by the Electric Lighting Act of 1882, which the UK Government had passed to prevent electricity companies from exploiting a monopoly position over their customers in the way water and gas companies had done in previous years. This Act restricted companies so that each plant could supply only one district and it gave the district authority the right to take over the plant after 21 years' service at a relatively low price. This effectively stopped the construction of new land-based power stations between 1882 and 1888. People applied for licenses to build power plants and supply electricity, hence controlling rights in a district, but relatively few new plants were actually built. In 1888, the Act was amended. The time before public authorities could take over a plant was extended to 42 years and the price became more favourable. This made electricity generation commercially attractive again and consequently a large no. of projects arose starting in 1888.

In 1888, Parsons decided to build a power plant using steam TGs. This was located at Forth Banks close to the centre of Newcastle-Upon-Tyne. He found people prepared to invest in turbines and in January 1889 founded the Newcastle and District Electric Lighting Company (known as "DISCO") to build stations which would use and showcase his machines. Charles took the position of Managing Director. Forth Banks was the first station. The first of four generating sets with a 75 kW axial flow turbine was ordered in 1888 and installed in 1890. The machine ran at 4,800 revs/min and produced AC electricity at 80 Hz.

Clarke and Chapman disapproved of this venture. They were also disappointed that Parsons could not sell turbines to the Newcastle Upon Tyne Electric Supply Company (NESCO) which was another prominent local developer. DISCO appeared to be in competition with NESCO which implied no prospect of any orders from the latter. They asked Parsons to stop the venture or leave.

Parsons chose to leave. He raised funds and created his own company named CA Parsons & Co at Heaton Works on the east side of Newcastle in 1889. This site is known today as 'CA Parsons Works' and is part of Siemens.

Steam turbines vs reciprocating steam engines 1889 to 1904

When Parsons left, all rights to his existing patents remained with Clarke Chapman & Co. This meant that he could not build axial flow turbines. To overcome this, Parsons developed the World's first radial flow steam turbine. This was a 32 kW set running at 6,000 revs/min, fig.11. In this design the fixed and moving blades were formed as an integral part of cast wheels and so curved vanes could be used relatively easily. Fig.11 shows the original vane pattern.

Initially, the flow direction was radially inward but this was found to be a mistake as soon as the machine was tested. Water and any foreign material in the steam became trapped in the chambers – the steam flow tried to push it inward while centrifugal forces tried to push it outward. The guide vanes were destroyed in around one hour. The turbine was quickly redesigned to use outward flow and this eliminated the problem. When the change was made, the moving vanes were made narrower which helped their efficiency. The outward flow design was an immediate success.

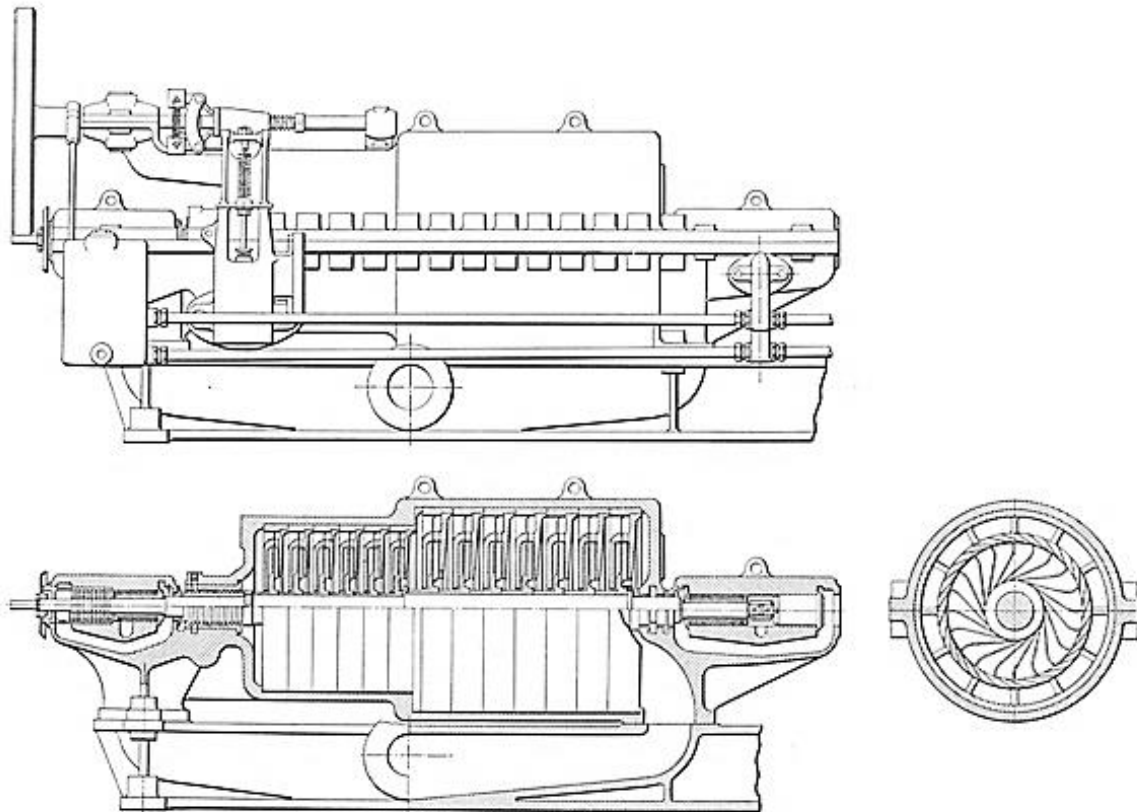

Fig.11 The World's first radial flow steam turbine 32 kW at 6,000 revs/min [3]

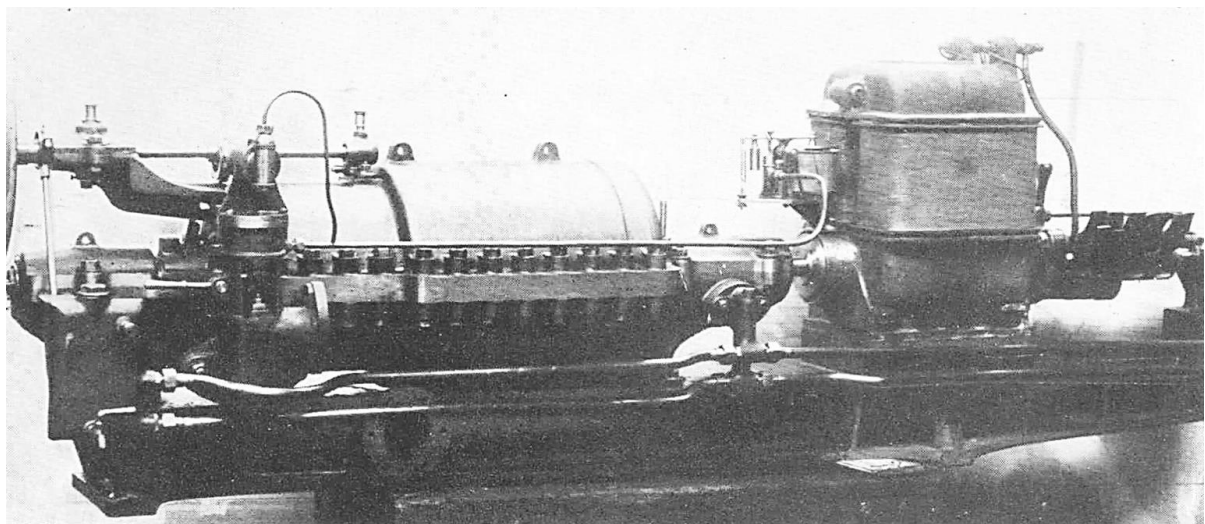

Fig.12 External view of the machine [3]

This machine became known as “Jumbo” as it was much larger in diameter than axial flow turbines and it was used extensively for experimental purposes at Heaton Works.

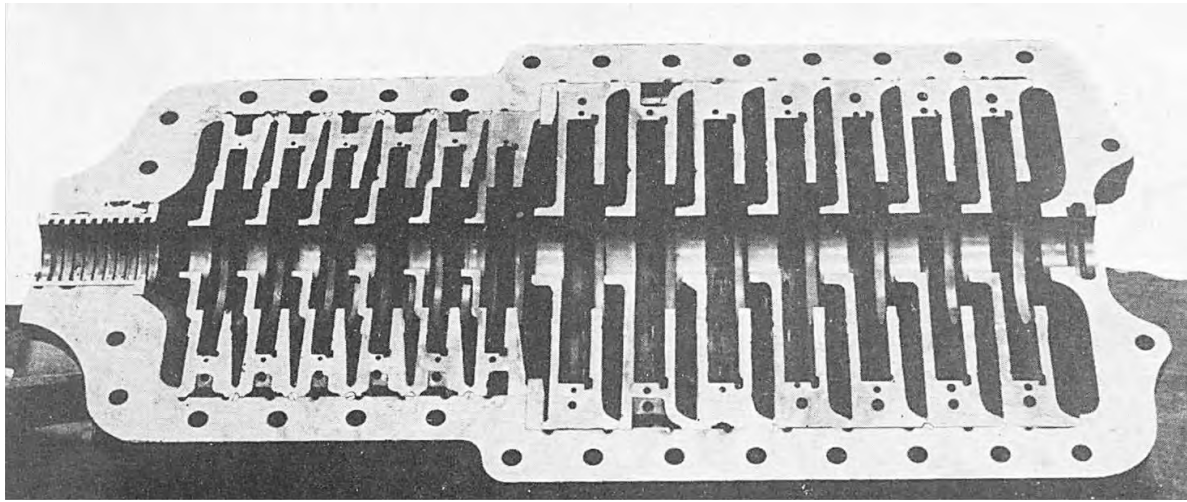

Fig.13 View of the cast plates or “diaphragms” which carried the fixed blades and formed the steam passageways [3]

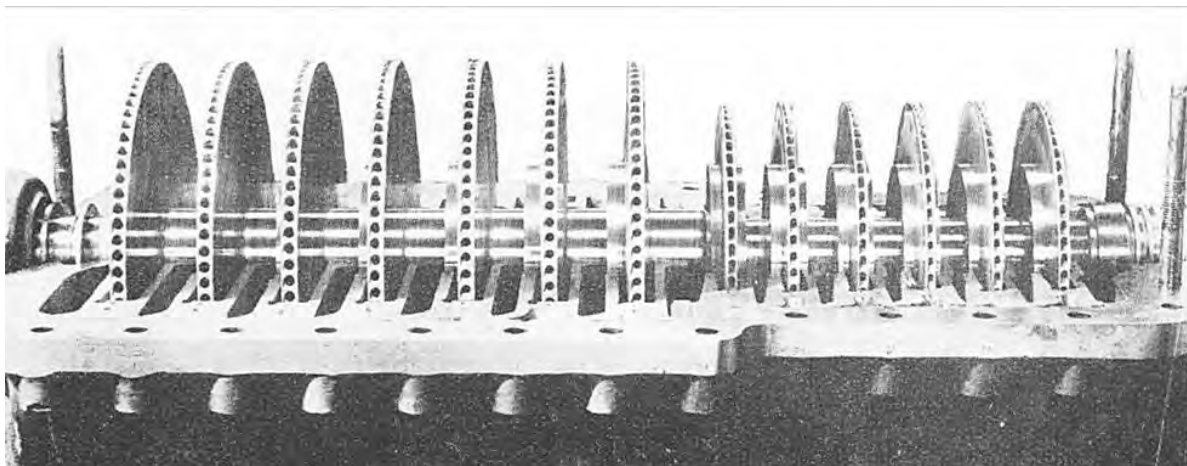

Fig.14 View of the brass wheels which formed the moving vanes [3]

Radial flow TGs were installed at Forth Banks to supplement the original four 75 kW axial flow machines. Some of these radial flow units may be seen in the Discovery Museum in Newcastle. Fig.15 shows a photograph of Forth Banks turbine-generator room.

By 1891, the UK power generation industry was dominated by the Willans high speed, central trunk, triple expansion steam engine. At this time, the total capacity of “large” generating sets (ie larger than 300 hp) in British central stations was around 33,000 hp (24.6 MW). Two thirds of these were Willans engines with direct drive generators, the remainder were belt driven sets of various makes. When the first turbine-generators were installed at Forth Banks, they represented approximately 1.5% of this capacity.

The supremacy of the Willans engine was virtually unquestioned throughout the 1890s. In 1895, the capacity of UK central power stations reached 101,390 ihp (approximately 68 MW) of which 52% was generated by Willans engines and 30% by Brush engines. These were the engines to beat.

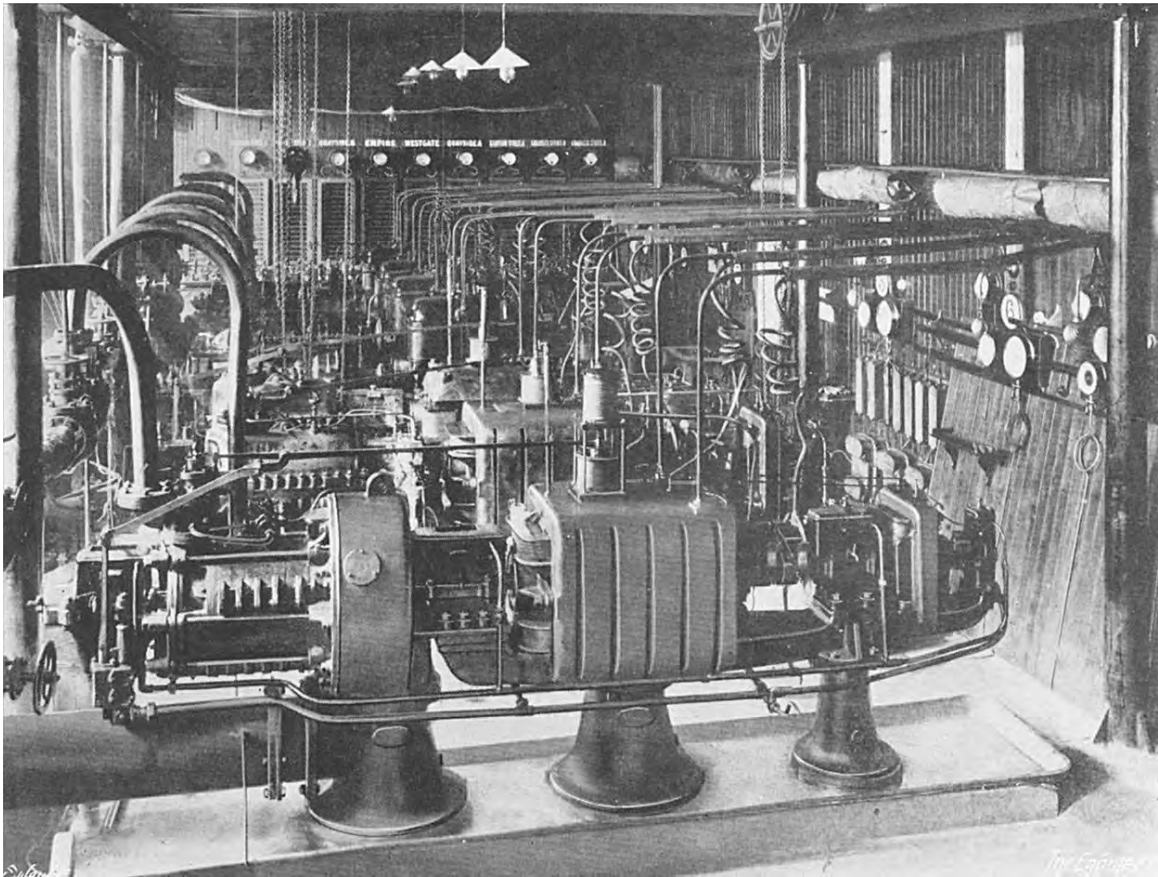

Fig.15 A photograph of Forth Banks Power Station taken in 1892 showing the original four axial flow machines in the background and subsequent radial flow sets in the foreground.

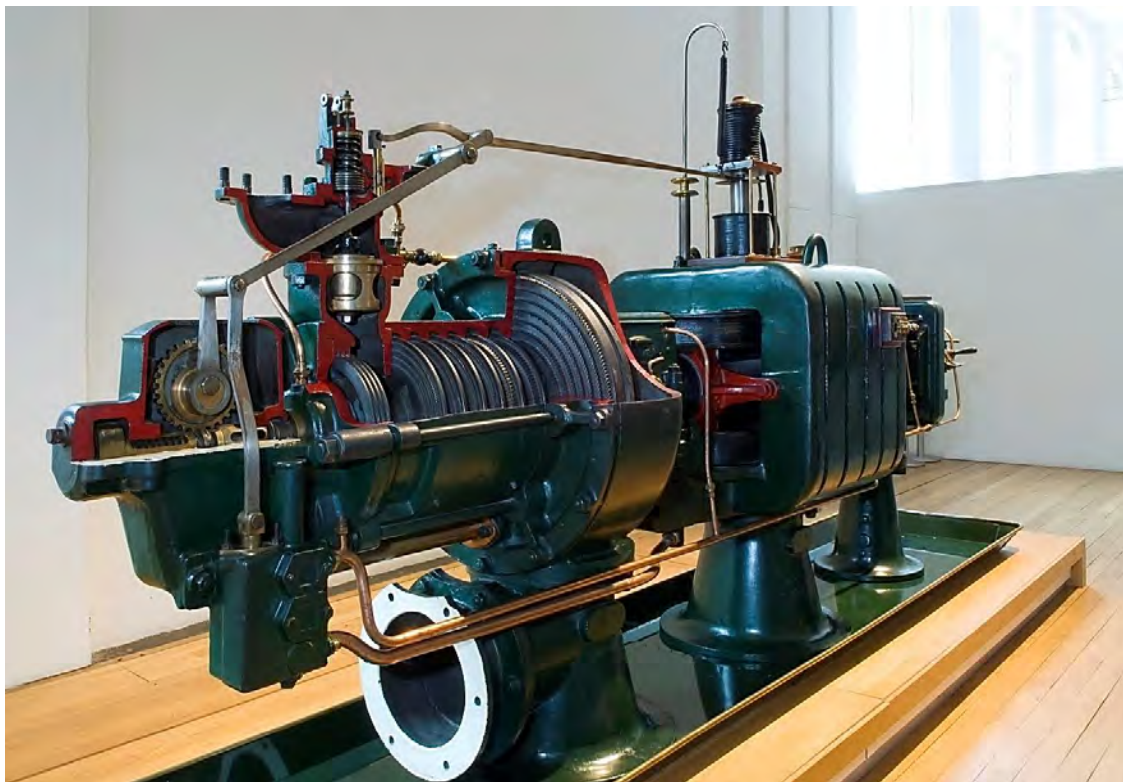

Fig.16 The first steam turbine-generator to use a condenser supplied to Cambridge in 1891
[Courtesy: Science Museum, London]

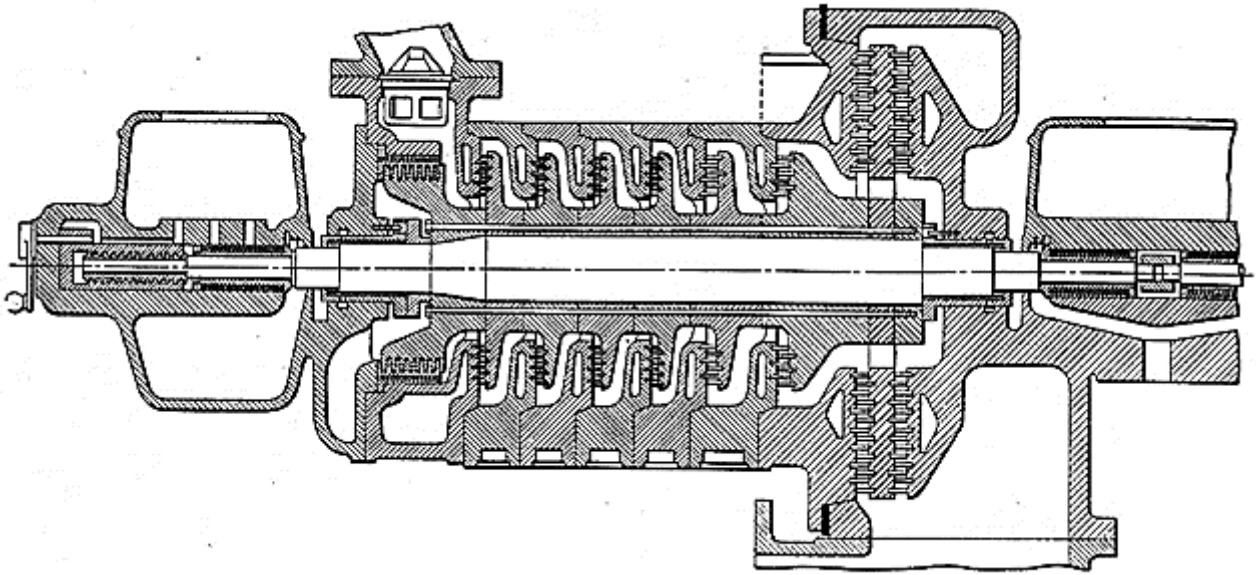

Fig.17 120 kW TG set supplied to Cambridge in 1891 [3]

One of the most important units was a 120 kW turbine-generator produced for Cambridge in 1891. This was the World's first condensing turbine-generator, figs.16 and 17. The Cambridge set ran at 4,800 revs/min and used steam at 140 lbs/in² gauge 361°F saturated (9.7 barg 183°C) although the machine could withstand temperatures up to 465°F (241°C) or more if necessary. The exhaust pressure was 1 lbs/in² abs (0.069 bar abs). The machine may be seen in the Science Museum, London.

This was the first turbine to achieve a steam economy comparable with a reciprocating steam engine of equivalent size. In other words, a steam turbine which did not operate at optimum velocity ratios, which had crude blading, poor blade seals and was limited by primitive construction achieved a performance level comparable with well-developed steam engines. This was the turning point in the competition between steam turbines and reciprocating steam engines.

It's an interesting design because:

- It used double flow low pressure blading to handle the huge increase in volumetric flow (m³/sec) produced by the low condenser pressure.
- It employed a dummy balance piston. This feature did not exist in 'Jumbo' two years earlier.
- A seven collar thrust bearing could be moved in service to adjust the tip clearances of the blades. This was a principle which would be used many times during the next 80 years to achieve and maintain high efficiency.
- It was the first turbine with casing glands packed with steam. This was necessary because the internal pressure was now sub-atmospheric.

In total, 120 radial flow turbines were produced between 1889 and 1894. The most powerful land turbine in this period was a 200 kW unit supplied to Portsmouth in 1893. The most powerful radial turbine Parsons designed was the original engine for Turbinia manufactured in 1894. This produced around 1,650 shp (1.23 MW) to drive a single propeller at 1,600 - 1,700 revs/min, fig.18. So, within 10 years of the prototype machine, turbine size had increased by over 160-times.

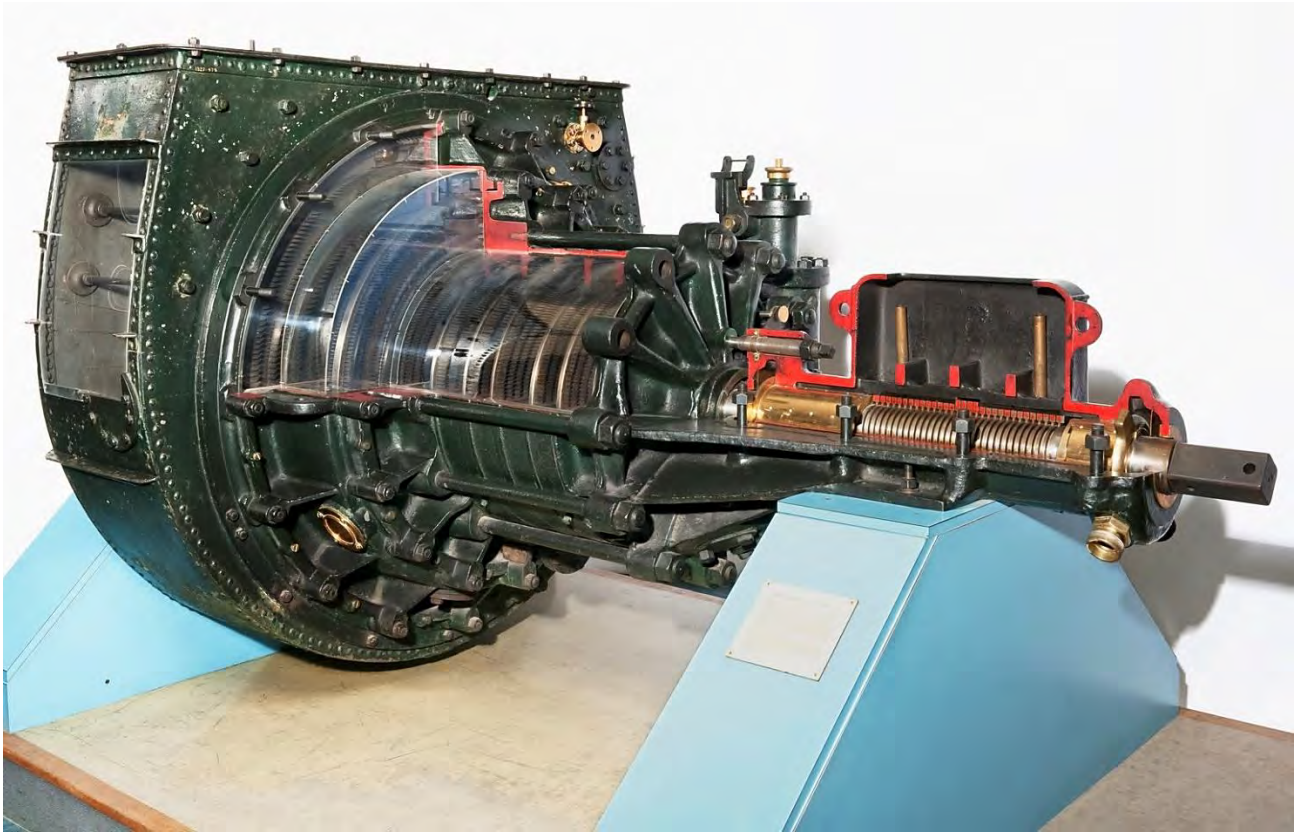

Fig.18 The original radial flow turbine installed in Turbinia 1894
[Courtesy: Science Museum London]

While Clarke, Chapman and Parsons had parted company, they were still on amiable terms. The reason Parsons didn't retain the rights to the axial flow turbine was simply the fact that the three men had been unable to agree the value of the patents. In 1894, a value was agreed and Parsons regained access to his original patents. Since the axial flow turbines were typically 12% more efficient than the radial flow designs, Parsons immediately stopped developing radial flow turbines and concentrated on axial flow.

One of the first axial flow machines to be built at Heaton Works was a 350 kW 3,000 revs/min unit for Manchester Square Power Station in London, ordered in April 1894, figs. 19 and 20. This unit operated at 150 lbs/in² gauge (10.3 barg) slightly superheated and exhausted to atmosphere. This machine was considered to be enormous at that time.

In 1893, the station had ten Willans high speed reciprocating steam engines. People living nearby complained about excessive noise & vibration and took legal proceedings forcing the station to modify or close the plant. Modifications were attempted but were ineffective. The turbine cured these issues.

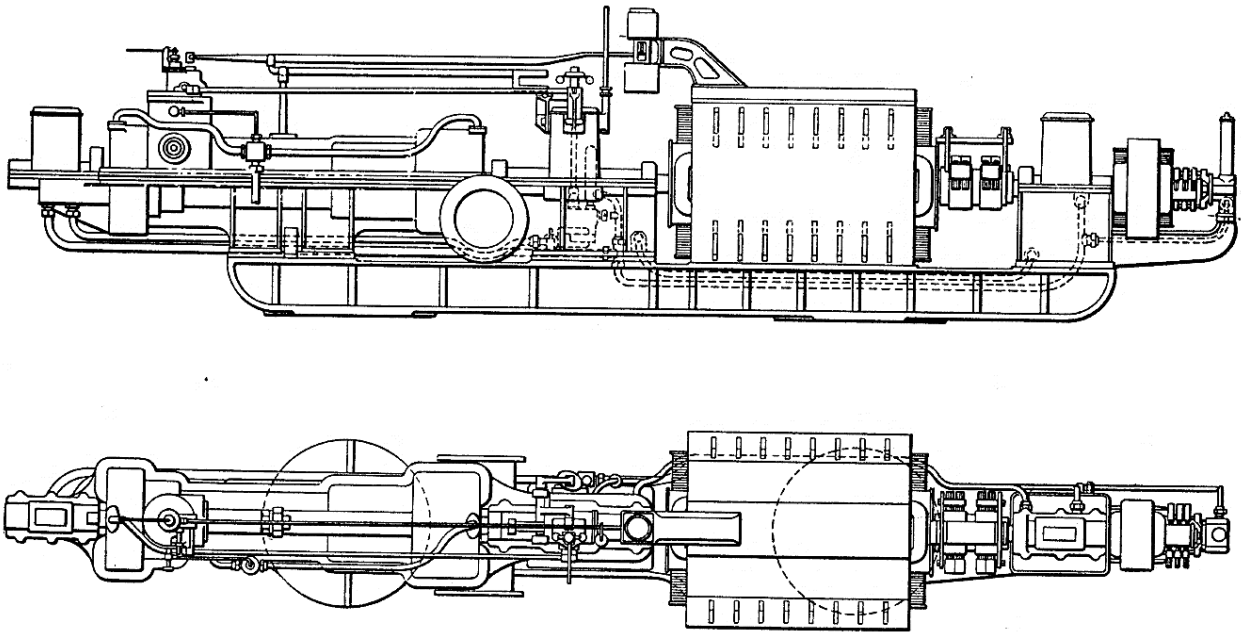

Fig.19 Side and plan views of the Manchester Square 350 kW unit [3]

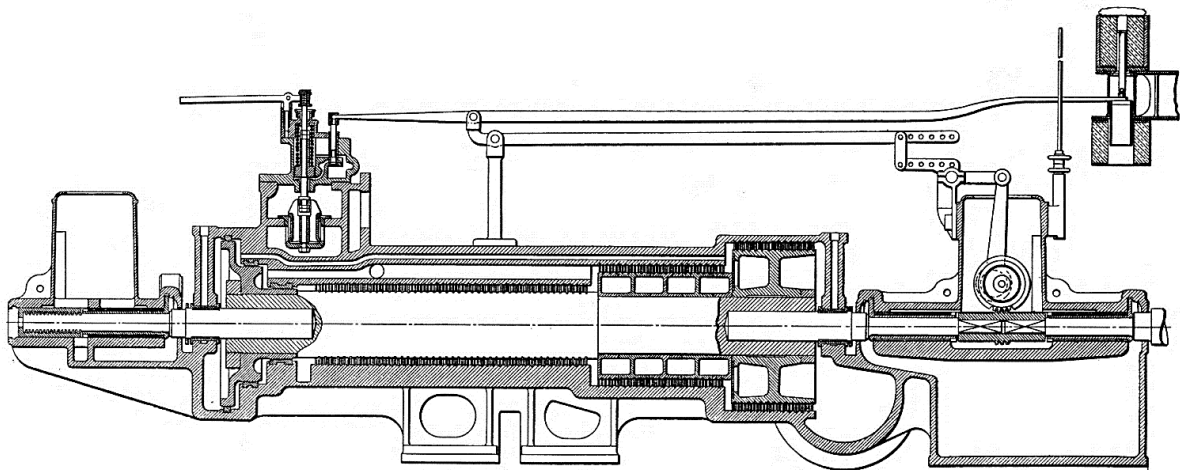

Fig.20 Cross-section through the 350 kW turbine [3]

Key features of the 350 kW turbine:

- A disc construction rotor was used, each step in diameter was $\sqrt{2}$ times larger than the preceding diameter.
- The single flow design helped to increase blade heights and so reduced tip leakage & secondary losses.
- Each step in the blade path was balanced by its own step in the balance piston.
- All blades were 1" tall (25.4 mm) cut as a series of slots (like the teeth of a comb) in bars of delta metal, then the bars were curved to match the rotor or casing and caulked into grooves.
- Delta metal was high strength brass – this was used because earlier blades were prone to fracture.
- V shaped fins in the glands were coated with lead or solder and allowed to rub in service to form their own running clearance ie this was the first use of abradable seals in turbines.

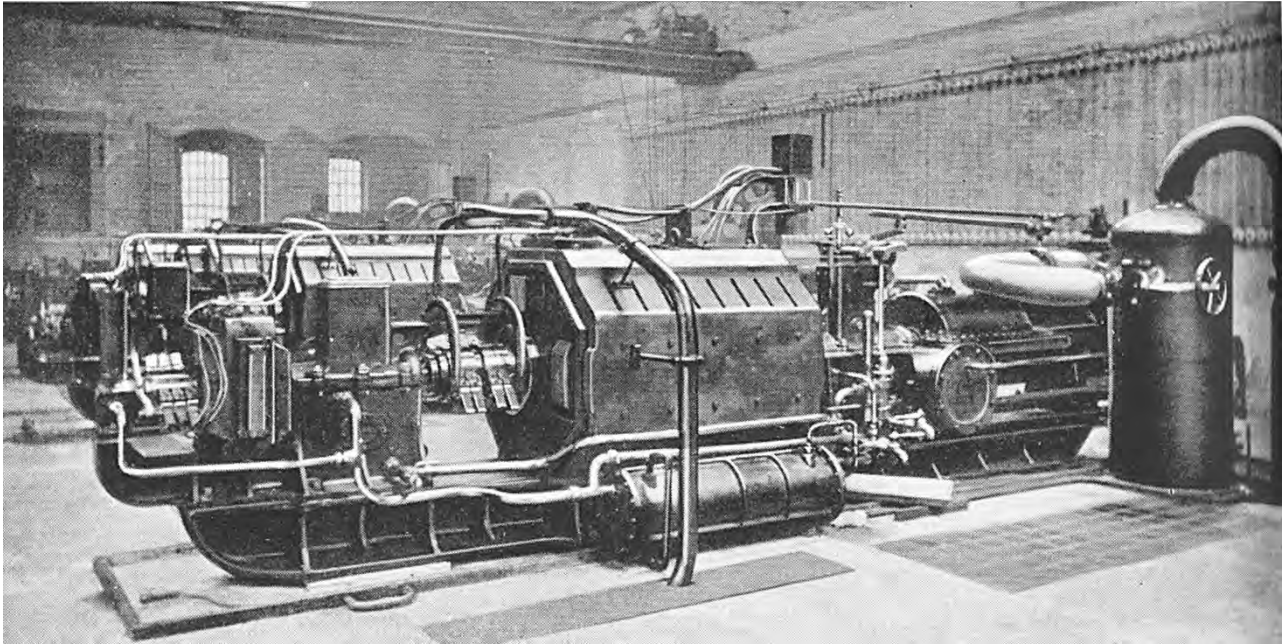

Fig.21 Photograph of 350 kW turbine-generators at Sardinia Street PS in London, a sister station to Manchester Square PS [3]

The turbine operated with low vibration and noise as desired, but it also brought the key advantages of improved efficiency, greater reliability, small size and low running cost. One of the most attractive features was the ability of the turbine often to keep running after sustaining damage, when a reciprocating engine could not. For example, when water carry-over from the boiler entered a reciprocating steam engine, severe damage generally occurred which forced the machine out of service for immediate repair. When water entered a Parsons turbine, a number of stages of blading might detach, but the machine would often keep running with no loss of output. Since the power produced by a turbine is nominally the mass flow rate (kg/sec) multiplied by the available energy per kg of steam (J/kg) times the blading efficiency, when a group of blades was lost in these early machines, the following effects occurred:

- With fewer stages in the blade path, the turbine could swallow MORE steam i.e. the flow rate increased.
- The inlet (boiler) and outlet conditions (exhaust pressure) remained unchanged, so the available energy per kg stayed constant.
- The blading efficiency fell slightly since the stage loading increased, but the change was insignificant compared with the need to keep producing power.
- The stresses in the blades increased but they were sized conservatively and could generally withstand this.

So, after blade loss, often the turbine could produce the same or even more power and stay in service like this for several months until the station was ready to replace the missing stages. When reblading was required, it could be carried out quickly at site. This made the unit very popular.

The success at Manchester Square led to immediate orders for further units from the Metropolitan Electric Supply Co. By 1896, two 500 kW units had been installed at Amberley Road station, and eleven 350 kW sets units had been supplied for Sardinia Street and Willesden stations.

At this time, there were around 70 separate electricity generating companies in London. Achieving such a good result with Manchester Square and its sister stations led to great interest from other

companies and the reputation of Parsons machines rapidly spread, starting a growth in demand for steam TGs in the UK. With many studies by leading engineers and academic institutions confirming the advantages of turbines over reciprocating engines, even Willans and Robinson started taking steps to manufacture TGs. By the beginning of 1896, 623 Parsons TGs had been supplied to customers.

The reputation of Parsons TGs started to grow outside the UK also, with several companies taking licences to make Parsons machines. George Westinghouse was one of the most notable people who took a licence in 1896.

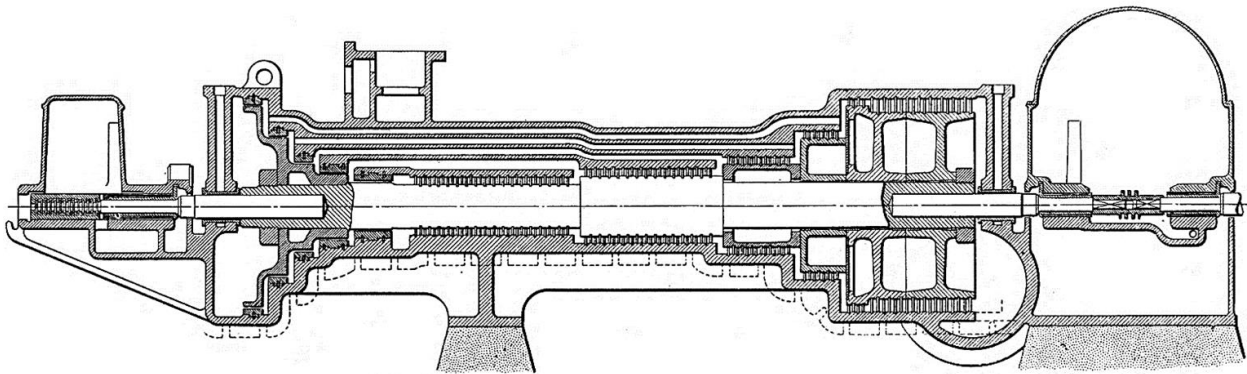

Fig.22 A 120 kW steam turbine sent to Westinghouse in the USA as a reference design in 1896 [3]

Parsons decided to send a turbine-generator to Westinghouse as a reference machine for familiarisation. This was a 120 kW TG set designed to run at 5,040 revs/min which had been ordered initially by the London House-to-House Electric Lighting Supply Co, fig.22. Subsequently, it became the first steam TG to produce electricity commercially in North America.

Since the speed was so high and the output relatively low, the first blade group was mounted on a small shaft diameter and there were five steps in diameter to accommodate the increase in the volume of steam as the pressure fell. It was not quite a conventional design, but it served its purpose and was immediately available. The rating 120 kW at 5,040 revs/min was dynamically equivalent to 338 kW at 3,000 revs/min which compared well with the Manchester Square machine (350 kW at 3,000 revs/min). It was therefore representative of the limit of the technology at that time, but it could be seen that the Manchester Square arrangement with a 3 step rotor was a less demanding design to produce.

While de Laval had used gearing by necessity on his steam turbines since 1886, Parsons built his first geared steam TG in 1896. This was a 150 kW set supplied to Forth Banks PS, figs.23 and 24. The turbine ran at 9,600 revs/min driving a generator at 4,800 revs/min to produce AC electricity at 80 Hz. The high speed meant that the turbine was dynamically equivalent to a 1.54 MW steam turbine at 3,000 revs/min ie 4.4 times the rating of Manchester Square. The machine operated successfully but Parsons decided to build synchronous, ungeared machines for subsequent large units.

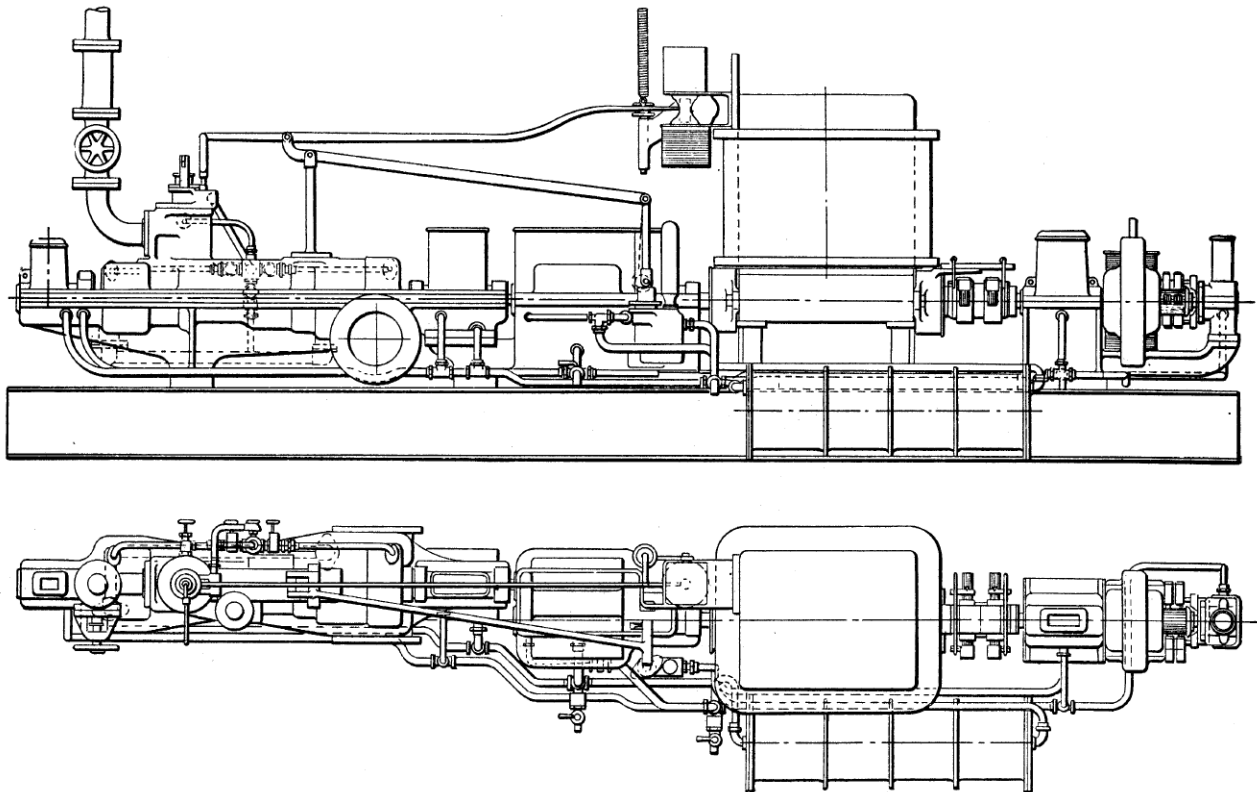

Fig.23 150 kW geared turbine-generator for Forth Banks 1896 [3]

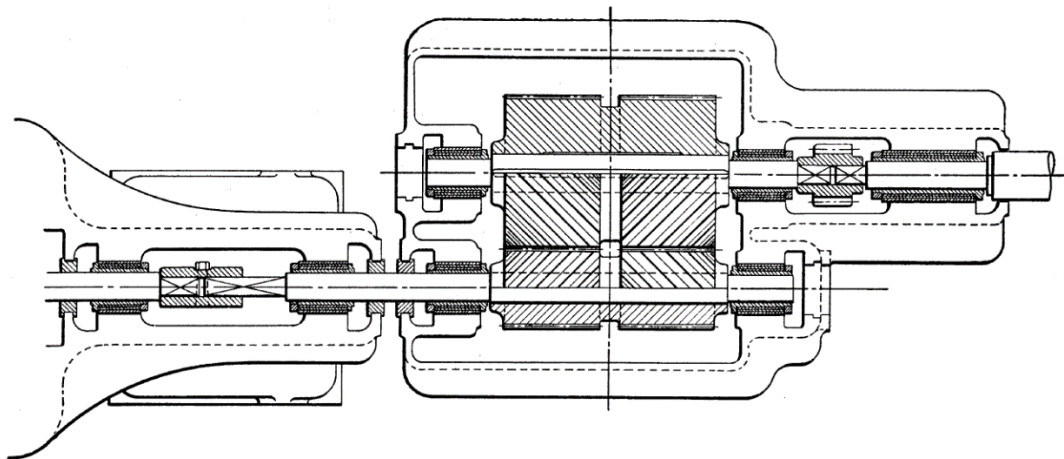

Fig.24 Configuration of the gearing in the Forth Banks TG [3]

The next major step in technology came in 1900 with the manufacture of two 1,250 kW units for the City of Elberfeld in Germany, figs. 25, 26 and 27. These were tested both at Heaton Works and at site under the scrutiny of Sir WH Lindley, Professor M Schröter from Munich Polytechnicum and Professor HF Weber from Zurich Polytechnicum. The machines achieved a steam consumption of 8.63 kg/kWh (16% better than guarantee) which was unequalled by any other type of steam engine.

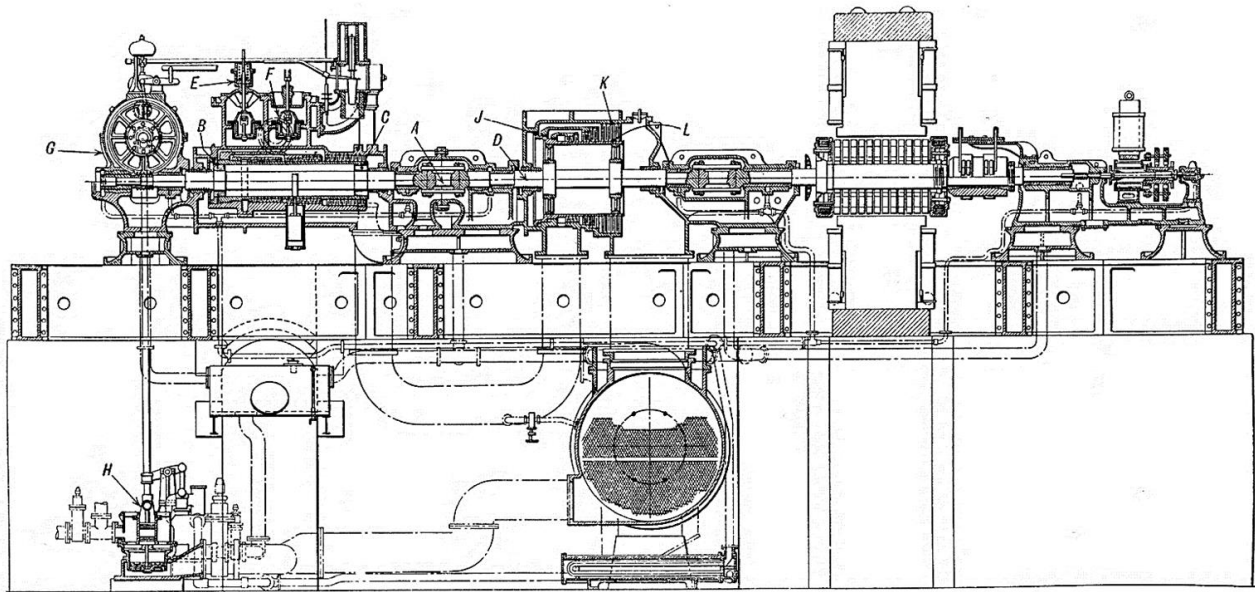

Fig.25 Cross-section through the Elberfeld turbine-generator [3] Steam was admitted through valve E and passed through the entire bladepath for loads up to 1,000 kW. Valve F opened allowing steam to bypass the first blade group (and so increased the swallowing capacity of the turbine) for loads up to 1,250 kW. The huge bedplate was used at the insistence of Sir WH Lindley who later admitted that it was unnecessary. [3]

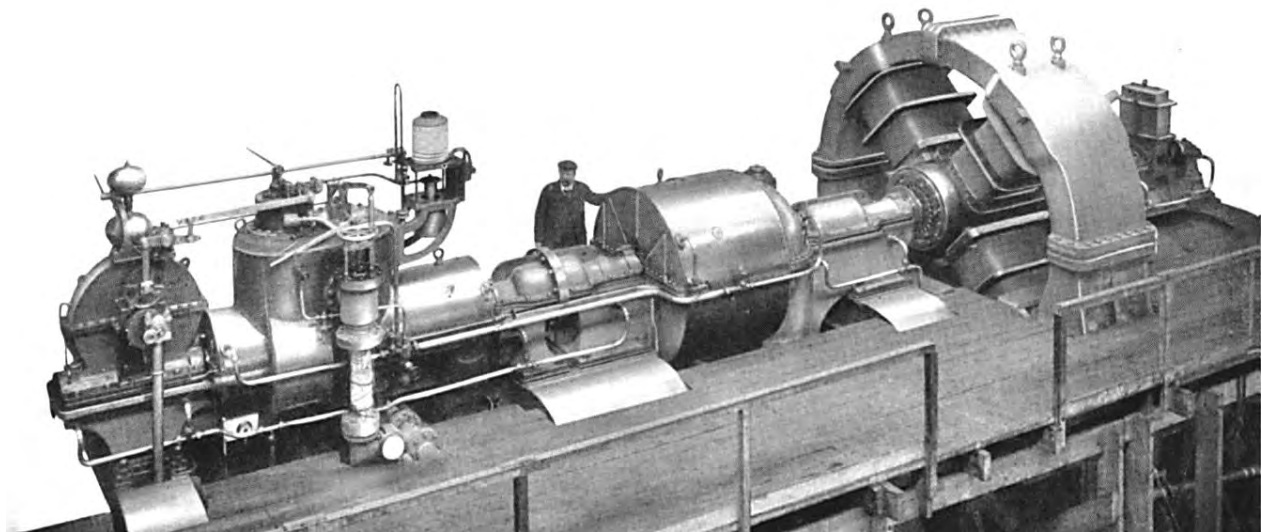

Fig.26 Elberfeld machine assembled in Heaton Works [3]

A locomotive boiler was used to reheat the steam before it entered the LP turbine during tests at Heaton Works. The steam temperature was raised by only 35°C to 127°C, far below the main inlet temperature of 232°C, and the reheat boiler caused an 8% pressure drop from 0.72 to 0.66 bar abs at the LP turbine inlet. Nevertheless, this achieved a 5% improvement in steam consumption. This gain wasn't enough to justify using reheat at the power station, but it was notable as the first use of reheat in trials on any steam turbine.

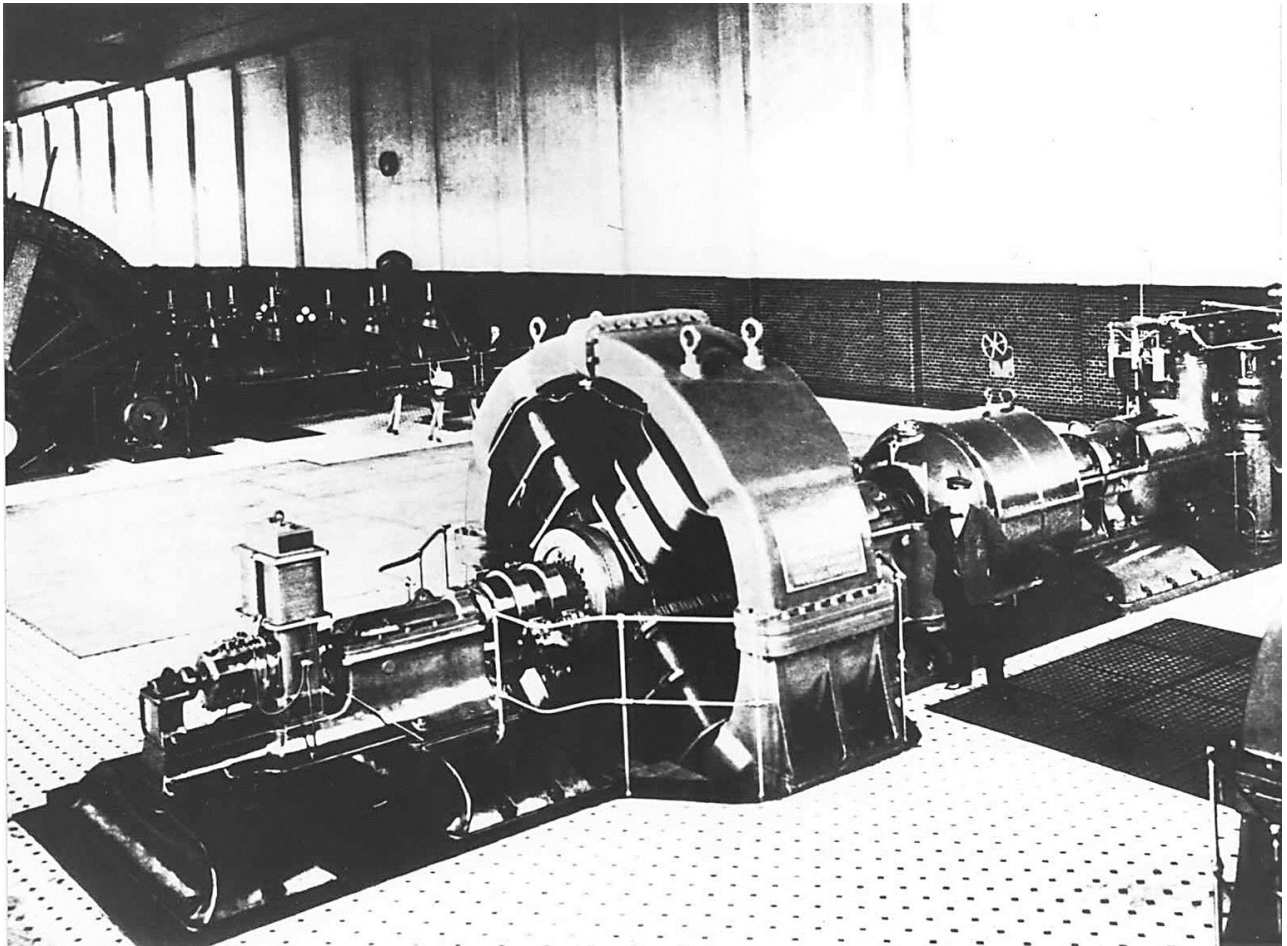

Fig.27 One of the Elberfeld 1.25 MW TG sets installed at the station

The excellent performance and the favourable operating characteristics of the units caused a sensation in engineering circles and quickly established the reputation of Parsons turbine-generators within Continental Europe. This led to a further increase in orders with more companies taking a licence to design and manufacture steam TGs. In particular, a joint venture was established between Parsons and Brown Boveri named the Aktiengesellschaft für Dampfturbinen System Brown Boveri-Parsons which held the exclusive rights to manufacture Parsons steam turbines for land use in Switzerland, Germany, France and Russia. In addition, the Mannheim site of Brown Boveri became involved in the Turbinia Deutsche Parsons Marine AG to build turbines for marine use. Brown Boveri built their first steam TG – a 250 kW unit – in 1901.

The Elberfeld units were twice as large as any other TG built up to that time and were considered to be of immense size by the industry. Separate HP and LP turbines were used for the first time in a land steam turbine, although separate cylinders had been employed in the second engines installed in Turbinia in 1896.

The speed of the Elberfeld turbines was only 1,500 revs/min, so (applying the principles of dynamic scaling) we can see that these 1,250 kW units were comparable in terms of technology with turbines of 313 kW at 3,000 revs/min. By reducing the speed, Parsons had made these units much less demanding to design.

In the next technology step, in 1902 Parsons designed a 1,500 kW turbine with only one cylinder, figs 28 and 29, which was installed in Neptune Bank PS in Newcastle-Upon-Tyne. Since companies in the North East of England had agreed to use 40 Hz electricity to satisfy the needs of

both traction (trams usually used 25 Hz electricity) and lighting (higher frequencies were preferred to prevent the lights from flickering), this machine ran at 1,200 revs/min.

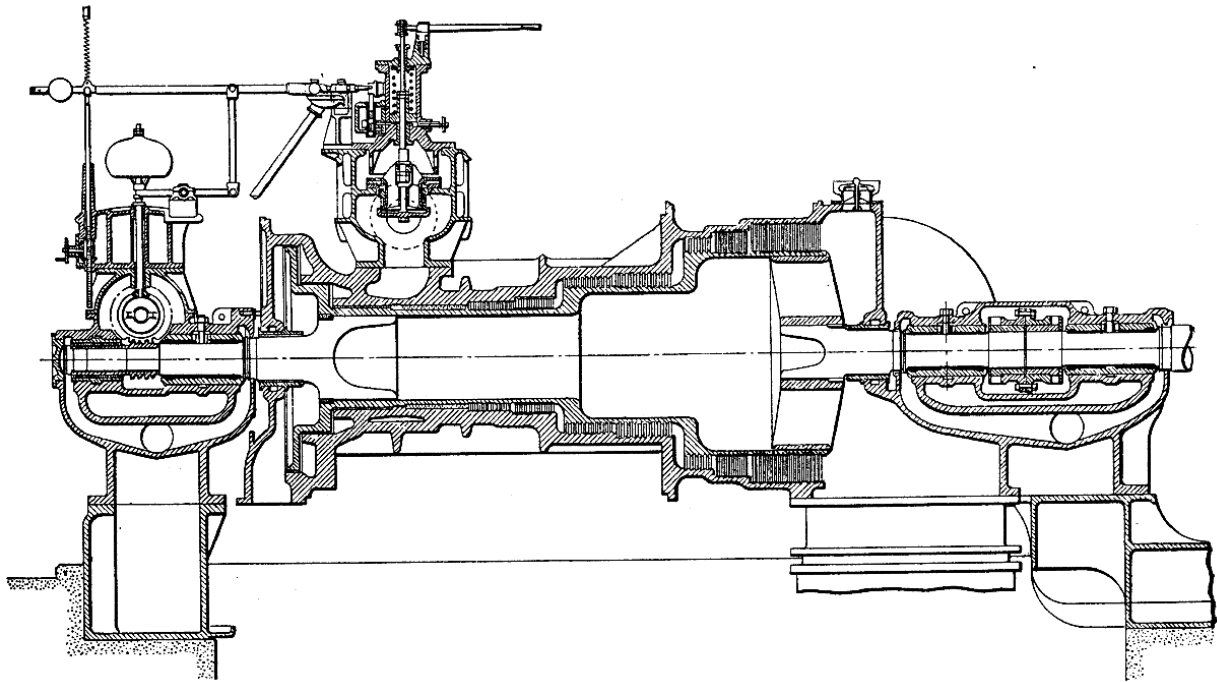

Fig.28 Cross-section through the 1,500 kW turbine for Neptune Bank 1902 [3]

Neptune Bank PS was opened in 1900 initially with three 800 kW 100 revs/min triple expansion, four cylinder, marine-type steam engines. Following news of the excellent performance at Elberfeld, the Parsons TG set was installed next.

This station played an important role historically. In 1902, Parsons had proposed to Cunard that steam turbines should be used as the main engines in the giant passenger liners *Mauretania* and *Lusitania*. Cunard established a committee of leading engineers to compare and assess the performance of steam turbines and piston engines. Neptune Bank was one of the main stations which they studied. They confirmed that the Parsons unit was 23% more efficient than the reciprocating engines at full load and maintained an advantage down to 75% load. Performance at lower loads in the trials was compromised by the fact the operators reduced the turbine speed dramatically with load simulating the behaviour of a ships' engine, a condition which did not occur during electricity generation of course and which wasn't required in an express passenger liner which usually sailed at constant speed. Cunard proceeded to install two 25.3 MW turbines in each of the ships, which proved to be a huge success. As a result, the ships held the record for the fastest crossing of the Atlantic Ocean from 1906 until 1929.

With a demand for electricity generation units in the 1 to 5 MW range after 1900, turbines were competing more with slow speed marine engines than the Willans type engine. With opportunities such as Neptune Bank to compare different engine types side-by-side, the steam turbine soon demonstrated its superiority.

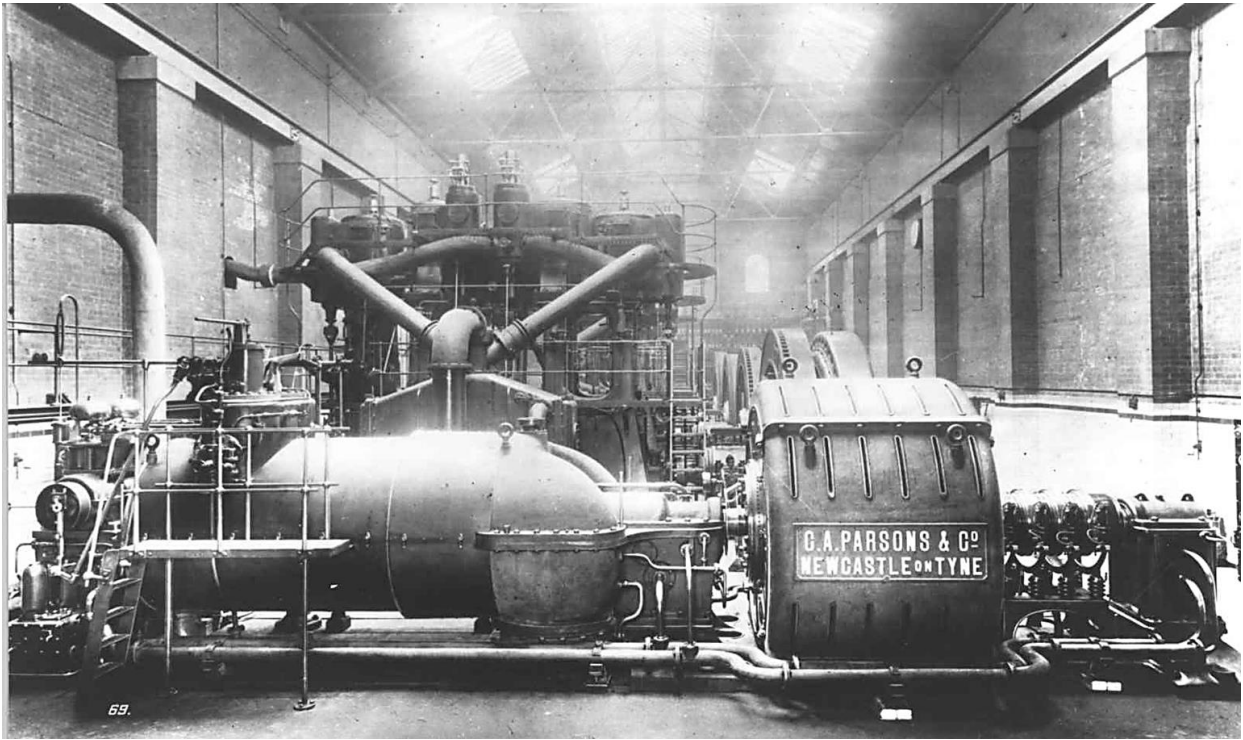

Fig.29 The 1,500 kW Neptune Bank TG set in the foreground with an 800 kW marine-type reciprocating steam engine in the background [3]

In 1903, steam TGs with an economical rating of 3.5 MW at 1,200 revs/min were installed at Carville A Power Station in Newcastle-Upon-Tyne, figs.30 and 31. These proved to have a maximum capability of 6 MW, setting a new record for TG power output. The inlet conditions were 200 lbs/in² gauge 540°F (13.8 barg 282°C).

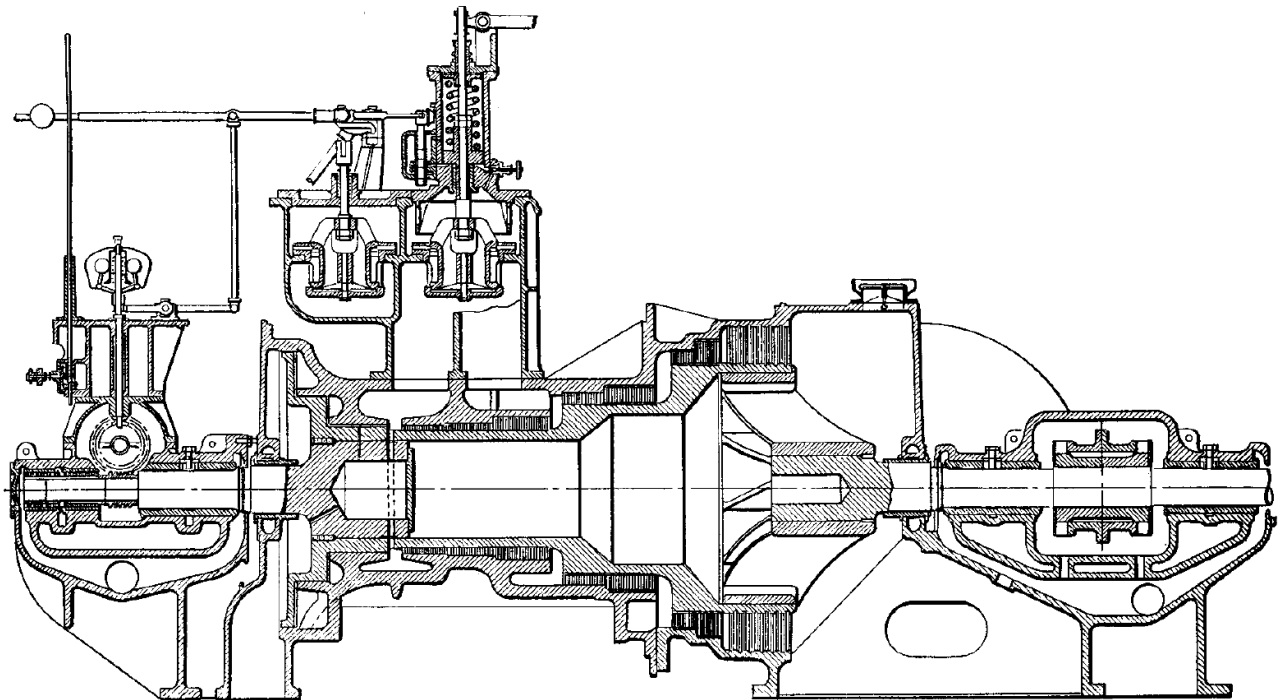

Fig.30 Cross-section through the Carville A turbine [3]

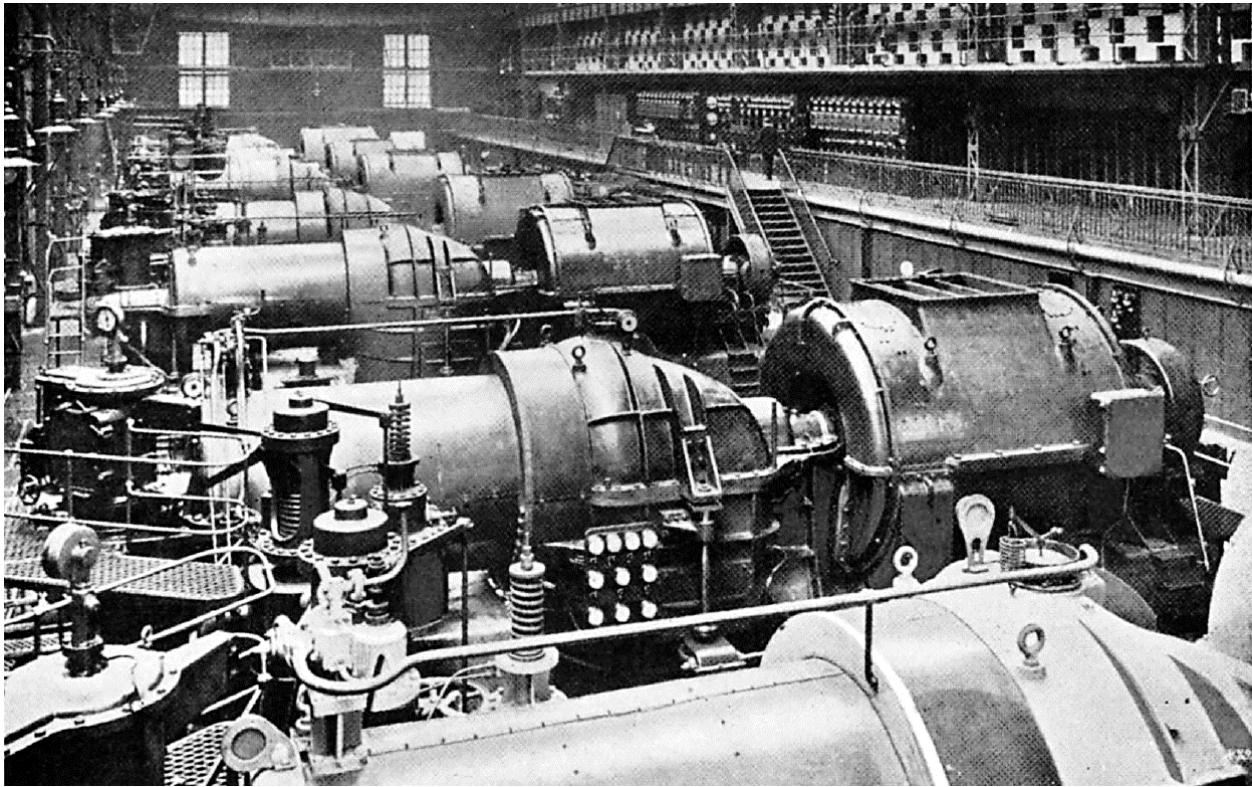

Fig.31 Carville A turbine hall, photograph taken in 1907 [3]

The steam consumption of these units (7 kg/kWh) was 19% better than Elberfeld (8.63 kg/kWh). Six turbines were installed by 1906. The third, fourth, fifth and sixth units employed 71 rather than 59 stages to improve the velocity ratio of the blading. This reduced the steam consumption to 6 kg/kWh, a further saving of 14%. These units were considered to be the most efficient in the World for several years. By 1907, the station employed these units plus another 2 machines of 4 MW rating and two 1.5 MW sets transplanted from Neptune Bank to give a nominal installed capacity of 32 MW (and a much higher overload capability). Only ten years earlier that would have represented approximately 50% of the total generating capacity of the UK.

By 1904, the reciprocating steam engine was considered to be entirely obsolete for electricity generation in the UK [3]. The last new reciprocating machine to be installed was a 5 MW unit at Greenwich PS in London in 1904. No further sets were ordered for any central power station in Great Britain, although existing machines remained in service until the National Grid was formed starting in 1926. The last large reciprocating steam engine in a UK power station was taken out of service in 1927.

The steam turbine was now dominant in terms of efficiency, power output, reliability, cost, upkeep, etc. One of the most prominent factors was plant size. Fig.32 shows a comparison in size between a Carville A TG set and a similarly sized unit with a reciprocating steam engine.

Blading technology had also moved on substantially. In the 1890s, blades with true aerofoils were introduced and by 1900, Parsons had adopted standardised designs – most notably the 400 series aerofoil, fig.33 – which achieved an aerofoil efficiency of 90%. This was used widely in both land and marine steam turbines.

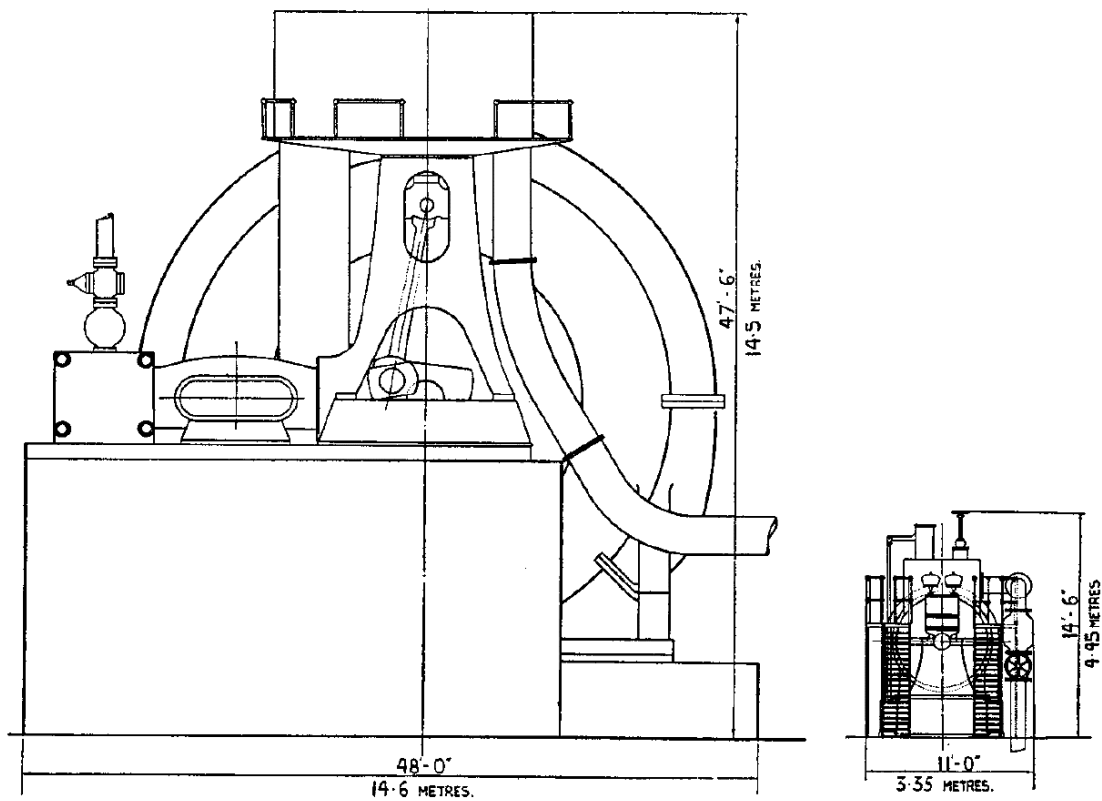

Fig.32 Comparison in size between a Carville A 3.5 MW TG set, *right*, and a reciprocating steam engine of similar power output, *left* [3]

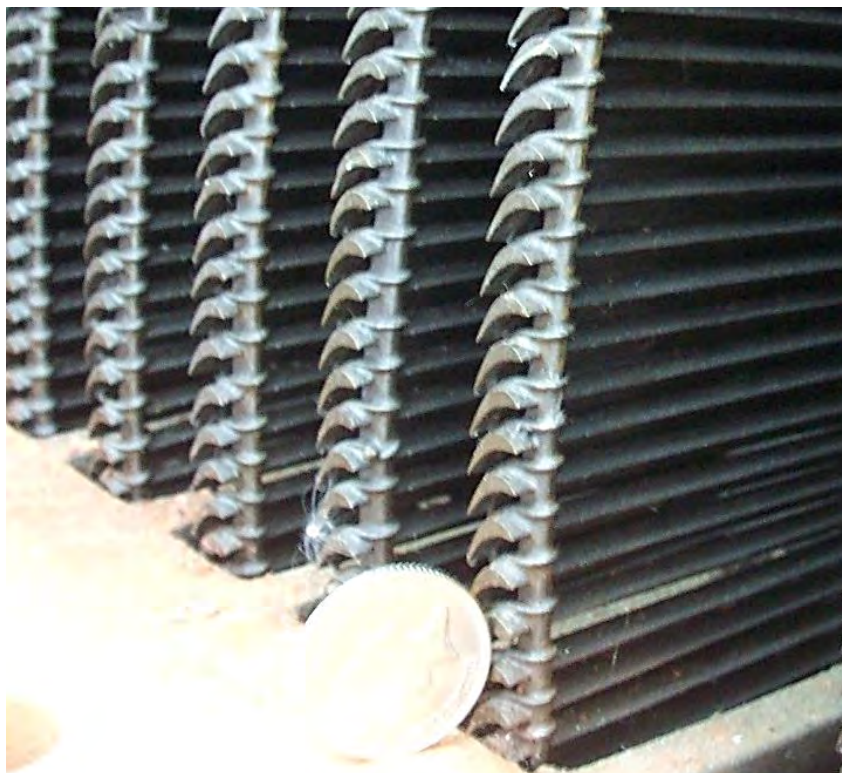

Fig.33 Photograph showing the type of blading used in turbines around 1900 – 1904 with a British 10 pence coin (24 mm diameter) in the foreground for scale

Factors which affected decisions on machine construction

From 1904, the power output of land steam turbines continued to grow. The main design questions were 'which configuration should be used' and 'at what speed'? Four configurations were considered by Parsons:

- Single cylinder turbines.
- Two cylinder turbines driving a common generator at a single speed on one shaft ie tandem compound.
- Two cylinder turbines each cylinder driving a dedicated generator on separate shafts ie cross-compound.
- Two cylinder turbines running at different speeds driving a common generator via a gear wheel ie geared cross-compound.

In the next section, we'll see which arrangements were chosen.

Other considerations included the relationship between machine speed & electricity frequency, the specified power output, no. of stages required, turbine exhaust area and the inlet pressure and temperature.

Speed & electricity frequency

Turbines usually powered generators with either two or four poles although a machine with six or more poles was occasionally used. If 25 Hz AC electricity was required, for example, 25 Hz = 25 cycles per second = 1,500 cycles per minute, then the turbine ran at a constant speed of 1,500 revs/min with a two pole generator or 750 revs/min if four poles were used. Speed and system frequency were therefore linked.

Low frequency AC was preferred for traction eg trams, railways and large motors in factories. A frequency of 25 Hz was adopted almost as a World standard for traction very quickly. This frequency had also been adopted by some water turbine companies eg the electricity produced using water from Niagara Falls was 25 Hz AC.

London Underground chose a frequency of 33.3 Hz and was an exception.

Higher frequencies were preferred for electric lights to stop the lamps from flickering. Since there was no National Grid before 1926, each generating company made their own decision on preferred frequency, generally using a figure between 40 and 80 Hz. AC electricity at 80 Hz implied the turbines had to run at either 4,800 or 9,600 revs/min which was difficult for large sets and so the highest frequencies were soon discontinued.

In North East England, 40 Hz AC was chosen as a good compromise for both traction and lighting.

If DC electricity was required, then the turbine-generator could run at any speed.

In the UK before 1926, it was a legal requirement for every district to make both AC and DC power supplies available to anyone who wanted them. There were two reasons for this:

- AC was preferred for arc lamps because the reversal of current shared the loss of carbon between the two electrodes and extended the life of the lamps. The power supply was held at a constant current (typically 10.5 amps).
- DC was preferred when incandescent light bulbs were used because batteries could be used to keep the lights on when reciprocating steam engines broke down. This also allowed generators to be much smaller and to run at constant, near optimum load as they were effectively being used just to recharge the batteries; they didn't need to be

sized to meet peak load. This improved the fuel consumption of the machines by a factor of two to three. Incandescent bulbs required electricity at constant voltage and so these had to run on separate circuits from arc lamps.

This led to a wide variety of operating speeds depending upon the customer until the National Grid adopted 50 Hz AC as a standard in the UK and other countries adopted their own standards, usually 25, 50 or 60 Hz.

Required power output

When customers specified higher power outputs, the principal effect was to increase the steam flow rate passing through the turbine. This required the flow area of each blade row to be increased. Consequently, larger machines used taller blades and larger shaft diameters to achieve this, with a moderate increase in blade throat width from inlet to exhaust also providing some extra area.

Of course, the rotational speed placed a restriction on the maximum shaft diameter which could be used. In addition, it was known that blades which were taller performed better than shorter blades, so the diameter of the inlet stages was kept small to ensure the front stages had an adequate blade height.

As machine sizes exceeded 10 MW, and as turbine speeds rose, it became necessary to specify a double flow blade path just to handle the volume of steam in the low pressure blading.

No. of stages required

Turbine blading produces peak efficiency at an optimum ratio of blade speed to steam speed U/C_0 where:

$$U = \text{blade speed} = \pi D \omega$$

$$D = \text{shaft diameter}$$

$$\omega = \text{shaft speed in revs/sec}$$

$$C_0 = \text{steam speed leaving the fixed blade row or nozzles calculated on an isentropic basis}$$

Where the optimum value of $U/C_0 = 0.98$ for reaction blading, 0.48 for Rateau single row impulse blading and 0.24 for Curtis two row impulse blading, approximately. The ratio U/C_0 is referred to in this paper as the 'stage loading'.

For a given blade speed, when the mathematics are worked out, this means that a reaction turbine requires twice as many stages as a Rateau turbine, eight times as many stages as a turbine using two row Curtis stages and eighteen times as many stages as a turbine using three row Curtis stages.

In conjunction with this, the efficiency of reaction stages is higher than Rateau stages and far higher than Curtis stages.

So, as machines became larger and the shaft diameters increased or the speed of the units increased, fewer stages were required. Conversely, if the speed had to be kept down, say to provide 25 Hz electricity for tramways, then the stage count might need to be high.

The type of blading used in each turbine type could be mixed (as we'll see), typically with an impulse stage at the front of the blade path to reduce the stage count. If the impulse stage was set on a large diameter, then one large impulse stage could replace over 30 reaction stages, for example, albeit with a loss in efficiency.

In the coming sections, we'll see how the blading type and stage count were varied due to this underlying logic.

Exhaust area

One of the key advantages of a steam turbine over a reciprocating engine was the ability to use the lowest available exhaust pressure, typically 0.5 to 1 lbs/in² abs (0.034 to 0.069 bar abs), whereas large reciprocating steam engines had to discharge at typically 9 to 10 lbs/in² abs (0.62 to 0.69 bar abs) due to the limited area of the exhaust ports. This meant that the pressure ratio from inlet to exhaust of a steam turbine was much greater than a piston engine, and so, much more energy per kg of steam could be extracted as power.

Very low exhaust pressures, of course, resulted in very low steam density and hence large volumetric flow rates at the turbine exit. In the early condensing machines, the volume of steam at outlet could be over 100 times that at inlet, and in later machines, the volume at exhaust could be over 2,000 times that at inlet even after extracting steam for feedwater heating. This required a large exhaust area in the most powerful machines.

The development of the tallest last stage blades and the highest blade tip speed which could be permitted within mechanical limits were therefore key issues in the development of turbines. These factors defined the maximum exhaust area (and hence maximum power output) which could be achieved and how many bladepath flows were required in the low pressure stages. Of course, an undersize exhaust could be used, but this increased the speed of the steam leaving the bladepath into the condenser and represented lost kinetic energy. Also, it was still necessary to keep the blades close to their optimum stage loading, so simply using an excessively large exhaust area could lose performance too. Consequently, in machines which were not close to the mechanical design limits, the exhaust area was optimised not just maximised, but last stage blade development directly influenced the possible size of machines.

A further consideration was the rate of erosion in the exhaust stages. Since saturated steam was used in the earliest machines, water was present everywhere in the bladepath. As steam pressures increased, more energy was extracted and wetness levels increased in the downstream stages. Superheat and the eventual adoption of reheat improved this, but designers were continually concerned about the risk of potentially excessive erosion due to high wetness and high blade tip speeds and this affected the size of last stage blades they were prepared to build.

Inlet pressure and temperature

Higher inlet pressures increased the pressure ratio over the machine and so increased the energy in J/kg which could be extracted from the steam. In turn, this meant that the corresponding steam speeds could increase. To maintain a satisfactory stage loading U/C_0 , the stage count had to increase unless the required power output needed a larger shaft diameter or the designer chose to use one or more impulse stages to counteract this. Stated in simple terms, the no. of stages used was determined by the pressure ratio of the turbine, and not primarily by the power output. Higher power outputs tended to increase the blade heights.

Higher steam temperatures reduced the strength of materials in service and so determined the choice of materials used. They also increased the energy which could be extracted slightly and so had a secondary effect on stage count.

The second era of growth in power output 1904 to 1930

Initially, single and twin cylinder, single shaft machines were built.

In 1908, two units of 7.5 MW maximum output were ordered for Ultimo PS in Sydney Australia. These were required to provide electricity at 25 Hz for tramways and so ran at 750 revs/min. To maintain a reasonable blade speed, the diameters of the shafts were physically very large, up to 66" (1.68 m). The first shaft was produced as a casting, but the second was produced as a hollow forging, figs.34 & 35, and was one of the largest forged shafts produced by Parsons before 1930 [3].

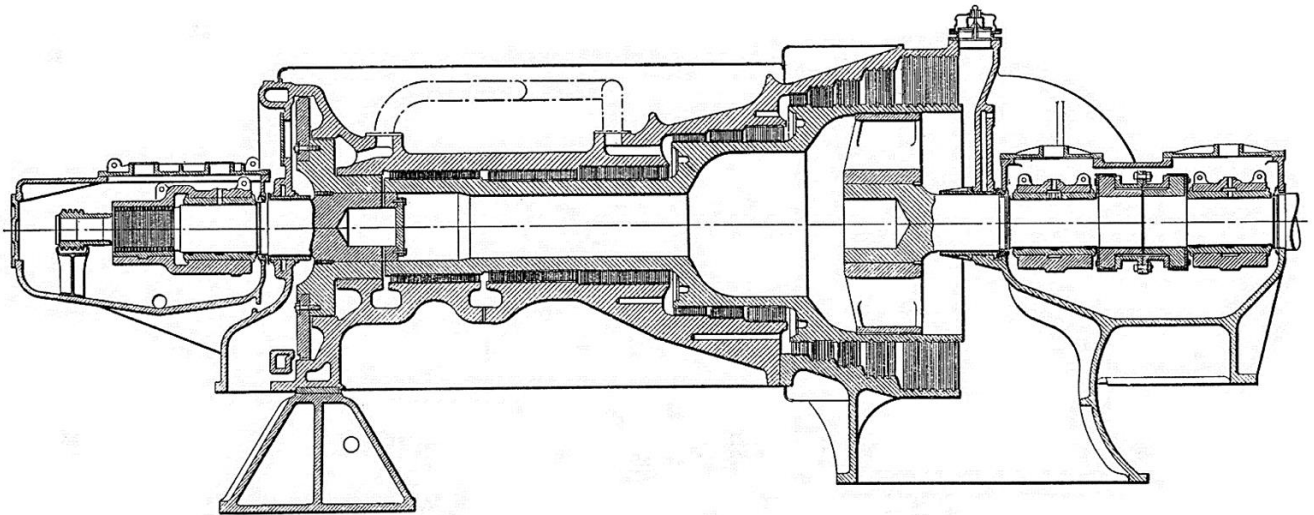

Fig.34 Sydney Ultimo turbine 5 MW economic, 7.5 MW maximum load at 750 revs/min [3]

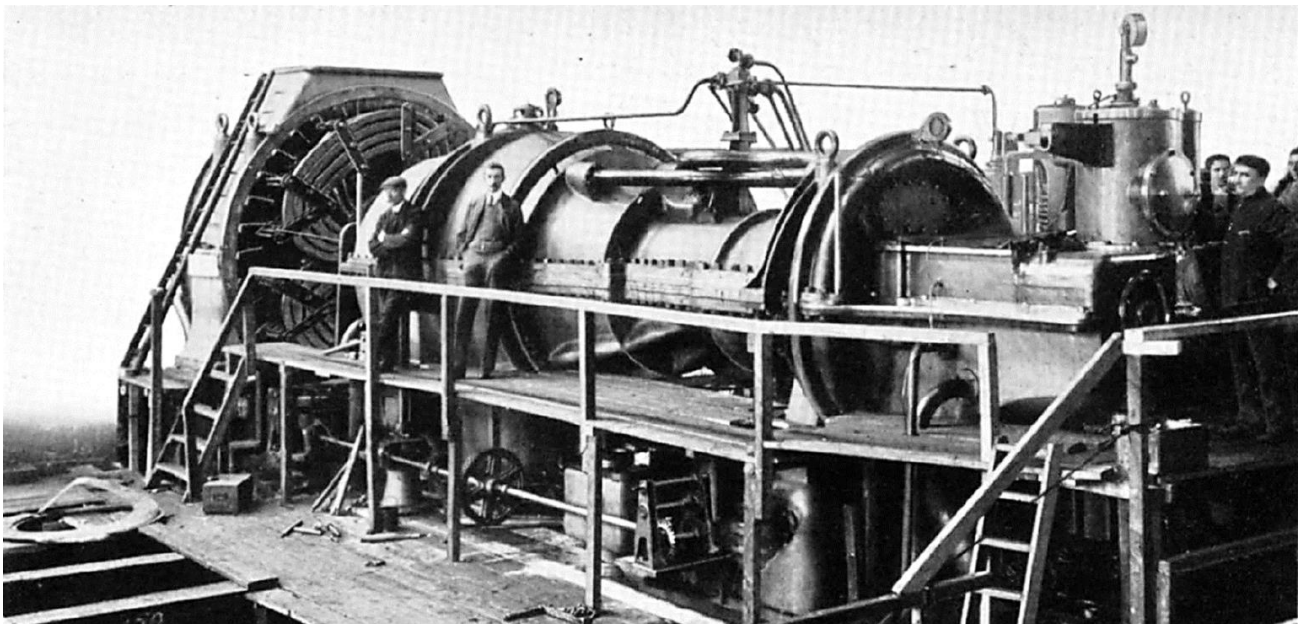

Fig.35 One of two Sydney Ultimo turbines under construction [3]

At this time, reaction blades were manufactured in segments, where strips of metal were rolled to form the aerofoils. In the Ultimo machine, the aerofoils were then caulked into slots in brass bars which formed the root fixings and lacing wires were attached. However, this soon changed to a

system where the root blocks were also rolled and the segments were assembled by using a wire passing through all of the root pieces, before brazing the parts together. The segments were then mounted in circumferentially serrated grooves in the rotor or casing, using small pieces of material as packing pieces between the segments and the grooves to fasten the blades in place. This latter arrangement was proposed by Willans & Robinson (after they became Parsons licensees) to help with the manufacture of the engines for RMS Mauretania, which used an enormous number of blades. It was so successful, it was subsequently used for the majority of reaction stages used in all Parsons turbines from 1908 until around 2005 including machines up to 800 MW rating.

Commencing in 1908, eight units of 10 MW maximum output at 1,000 revs/min were supplied to Lots Road PS, one of two stations which powered the London Underground. These were ordered to replace Westinghouse TG sets which had proven to be unsatisfactory. There were three key consequences:

- The fact that Westinghouse had supplied TG sets to the UK breaching the terms of the Parsons license led to an ending of the relationship between the companies (until the companies formed a new partnership in 1992).
- The Parsons machines were so successful, it led to further orders of even larger size. Lots Road subsequently used only Parsons turbines from that time until the station closed in October 2002.
- The turbines were essentially similar to the Elberfeld units ie two cylinder with single flow LP turbines, fig.36. Together with similar units of 9 MW at 1,500 revs/min supplied to South Africa, this would be last time this configuration would be used.

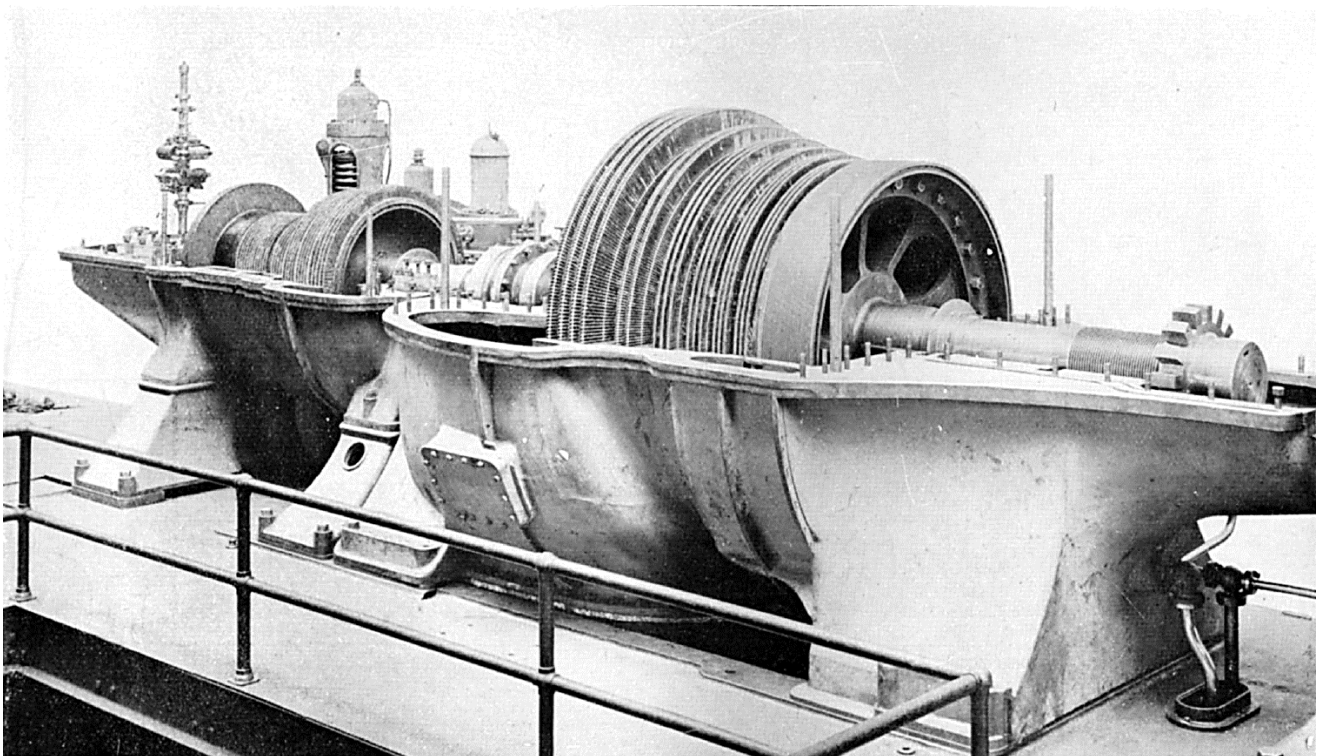

Fig.36 One of the Lots Road 10 MW 1,000 revs/min turbines [1]. The HP turbine shaft was a solid, single piece forging while the LP turbine shaft was hollow and assembled on 'spider' shaft ends.

In steam turbines, the pressure in the inlet stages varies in proportion to load, approximately. So, at 50% load, the pressure at inlet to stage 1 is approximately 50% of the full load value. Since early boilers operated at constant pressure (and many machines took steam from a common steam range), this meant that the inlet valves throttled at part load and the drop from full pressure in the steam range to a partial pressure inside the machine represented potential energy which could not be converted into power. Valve throttling losses were therefore a key factor while running at part load. Between 1900 and 1910, different inlet arrangements were introduced to minimise these losses. At first, bypass governing was used. This was an arrangement in which the first blade group could be bypassed using an extra inlet valve. While usually described as an 'overload valve', the design was intended to produce two power output levels at which there were no valve throttling losses – one load with the steam flow passing through the entire bladepath and the second when the flow could enter via the bypass (with the respective valves wide open). In the early 1900s, an alternative arrangement known as nozzle governing was adopted in which the first row of fixed blades was arranged in groups of blades or 'nozzle arcs', each arc was supplied by its own valve. Each group of nozzles was brought into service in sequence, changing the flow area of the first stage. By varying the available flow area – making the area smaller at lower steam flows – this had the effect of dropping the pressure across the stage rather than the valve. So, the associated potential energy was released in an orderly fashion in the stage rather than as chaotic flow in the valve, allowing it to be converted into power.

If the nozzle arcs were sized for very low loads, then the pressure drop across the stage could be very high and the stresses in the blades increased markedly. The blades therefore had to be robust which meant that a Rateau or Curtis stage was needed. This was convenient because the use of one of these stages also reduced the number of reaction stages required.

Sir Charles Parsons wasn't eager to use nozzle governing at first but was persuaded after insistence by his leading engineers, his licensees and the industry. This configuration worked reasonably well except for one notable case. In 1910, Parsons supplied two 7.5 MW 1,000 revs/min turbines operating at 170 lbs/in² gauge 500°F (11.7 barg 260°C) to Deptford PS in London. These were intended to be all-reaction bladed machines, but the low speed and relatively high pressure resulted in a large stage count. There wasn't enough space for this. Parsons therefore decided to use a Curtis stage at inlet. He preferred a two row impulse wheel with a diameter of 10 feet 6 inches (3.2 m), but the largest wheel forging he could obtain was 9 feet 6 inches (2.9 m). He was also concerned that windage losses could be excessive. Parsons therefore decided to use a three row wheel with a diameter of 7 feet 6 inches (2.3 m). In the next three decades, three row Curtis stages were used frequently for marine (astern) turbines and achieved peak efficiencies of around 40 – 50%, but with the short nozzle arcs and more primitive aerofoils used at Deptford, this stage will have produced most of the power output of the turbine with an efficiency potentially less than 30%. In addition, high dummy piston leakage occurred due to casing distortion. The units therefore failed to meet the steam consumption guarantee until modifications could be made after World War I.

The Deptford turbine design is shown in fig.37. So, while this design fell short of expectation, other machines of similar layout using two row Curtis stages (and later, Rateau stages) operated perfectly satisfactorily.

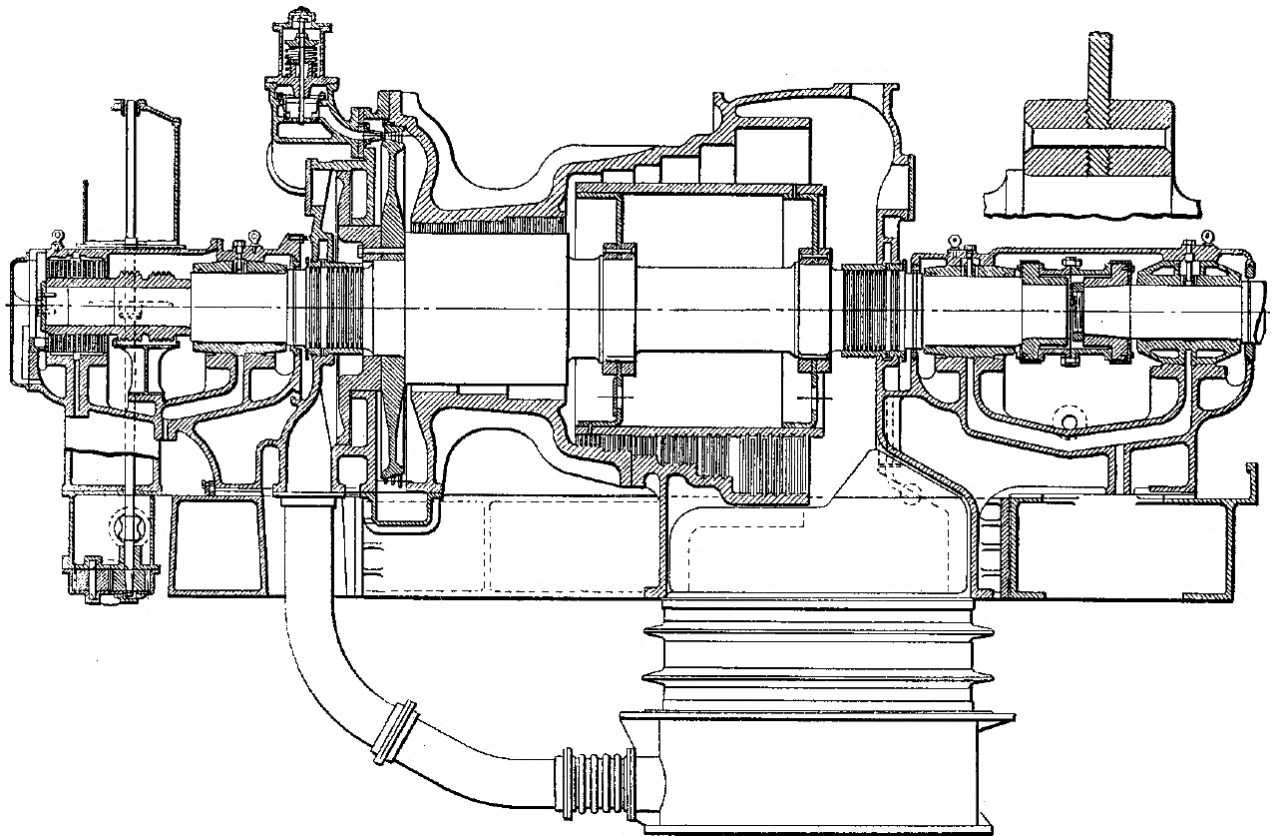

Fig.37 7.5 MW turbine at 1,000 revs/min supplied to Deptford PS in 1910. [3] The three row Curtis stage was set on a diameter 2.26 times the first reaction stage diameter, and so, had the capability of replacing up to 90 reaction stages, albeit with a low stage efficiency.

This was a period in which Sir Charles built turbines with various configurations. In 1910, he built a 4 MW TG set with a cross-compound, separate shaft arrangement for Bankfoot PS in Newcastle, fig.38. Compared with the 1,000 revs/min turbines supplied to Lots Road and Deptford, this 4 MW unit with turbines running at 2,400 revs/min was dynamically equivalent to 23 MW at 1,000 revs/min ie much more demanding technically. This is why a double flow LP turbine was required at this machine size and why two alternators had to be provided. The inlet conditions of 200 lbs/in² gauge 538°F (13.8 barg 281°C) normally would have needed a high stage count, but the high speed counteracted this and kept the blade paths short.

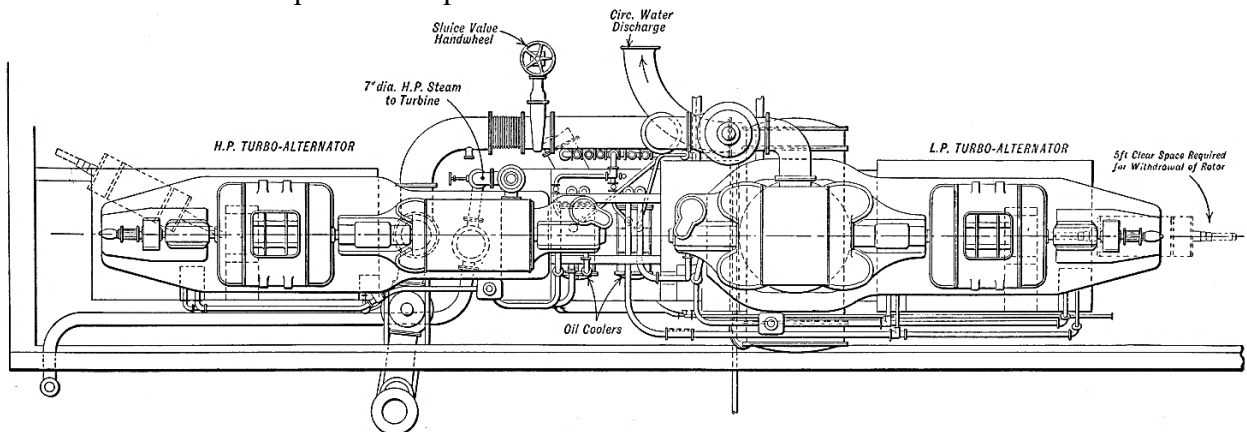

Fig.38 Plan view of the 4 MW 2,400 revs/min cross-compound TG for Bankfoot PS in Newcastle-Upon-Tyne 1910 [3]

The Bankfoot turbine showed that grey cast iron could deform when the steam was superheated. In subsequent machines, Parsons turbine casings operating at 450°F (232°C) or above were usually made from carbon steel.

In 1912, a 25 MW Parsons unit was built for Fisk Street PS in Chicago, figs 40 and 41. This was the largest and most efficient TG set in the World at that time. The electricity generation system in Chicago was undergoing dramatic change due to Samuel Insull, President of the Commonwealth Edison Company in Chicago, fig.39. Insull understood the potential savings in operating cost which could be achieved from large scale generation and started ordering very large TG sets. The first steam TGs installed at Fisk Street were General Electric designs with rated outputs of 5 MW at slow speed. These were amongst the first Curtis turbines produced by GE and became operational in 1903. They employed four row Curtis stages and used a lot of steam. Around 1909, Insull described these initial turbines as “pipes that passed steam” [5]. Six years later, Insull installed new 12 MW GE Curtis TGs to replace the earlier units. This improved the plant efficiency, but Insull had an even greater target in mind. When he ordered the Parsons 25 MW set, he increased the gains from ‘economy of scale’ and also obtained the efficiency advantages of a reaction turbine. Insull had seen Parsons TG sets in operation during a visit to Europe in 1901, and in 1912, considered that only Parsons could build this size of unit reliably [6].



Fig. 39 Samuel Insull in 1910

The unit had to supply electricity at 25 Hz, so Parsons decided that it should run at 750 revs/min. This allowed a large exhaust area to be provided, which was needed because the cold cooling water temperature in Chicago allowed a good vacuum to be achieved in the condenser and it limited stresses in all parts of the shaft train. With inlet conditions of 200 lbs/in² 588°F (13.8 barg 309°C) and a slow running speed, the stage count required two cylinders, although the large shaft diameters helped to keep the bladepath lengths reasonable.

The HP turbine bladepath increased from a base diameter of 972 mm at inlet to 1,651 mm at outlet. The shaft was a hollow forging with a stub shaft at the outlet end which was shrunk and bolted in place, fig. 40. In later years, this would become known as ‘hollow and stub’ construction and would be used for the majority of large Parsons units up to 500 MW at 3,000 revs/min & 800 MW at 1,800 revs/min until the 1970s. This had the advantage of reducing shaft weight and hence bearing loads and it removed centreline forging defects, even though in 1912, engineers didn’t yet appreciate how important this would become. Bearings which developed a hydrodynamic oil film hadn’t been invented yet, so shafts ran in contact with the white metal of the bearing shells using oil only to reduce the coefficient of friction and to carry heat away. These bearings ran hot; consequently, many units used water cooled bearing casings, otherwise thick black oil smoke could fill the turbine hall [3].

The base diameter of the LP bladepath was 2,184 mm. The LP shaft was manufactured as a drum mounted on a central spider with flexible diaphragm plates supporting each end to allow for thermal expansion. Again, this saved a lot of weight.

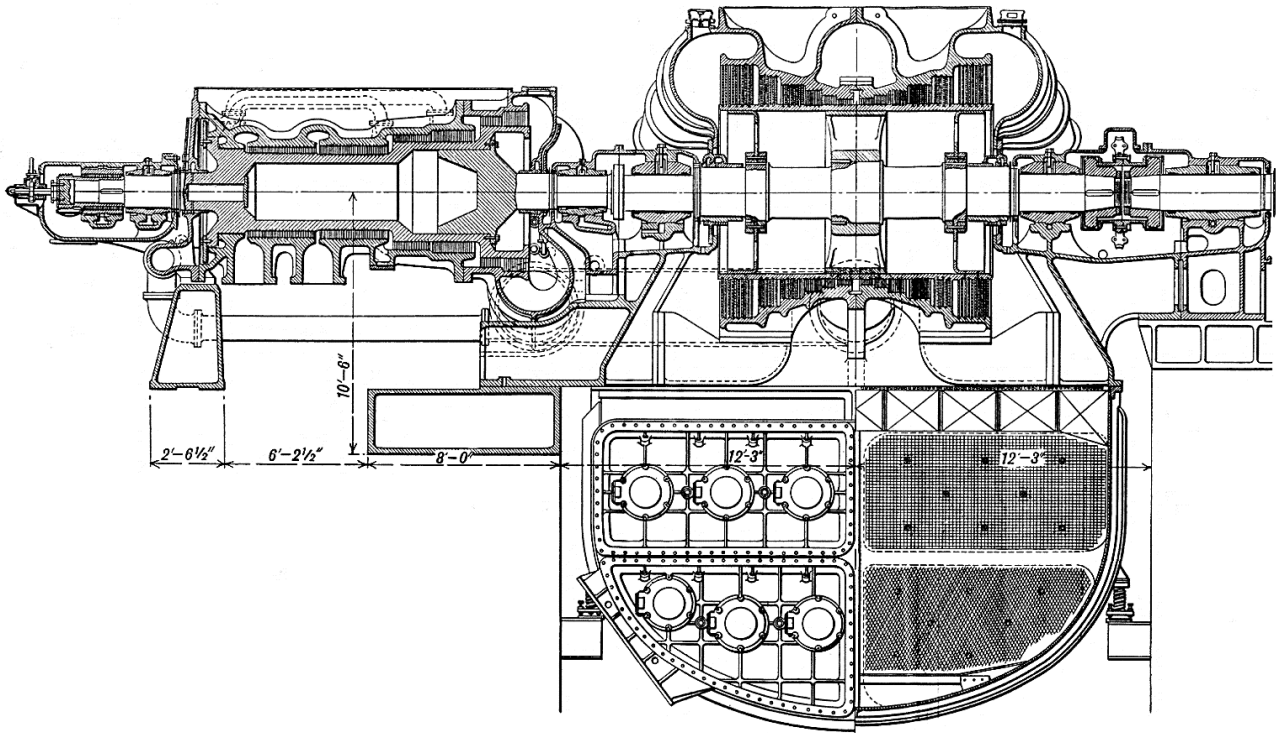

Fig.40 Cross section through the 25 MW 750 revs/min turbine for Fisk Street, Chicago [3]

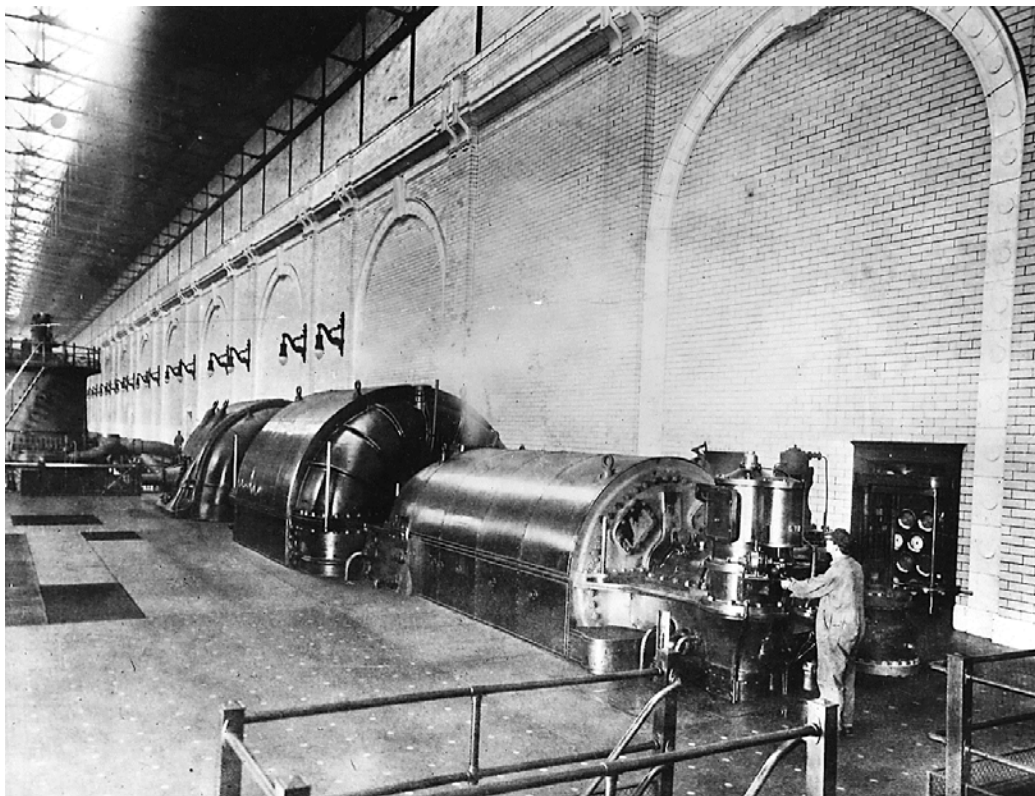

Fig.41 Parsons 25 MW TG set 'Old Reliability' in the foreground with vertical axis Curtis turbines in the background, Fisk Street PS Chicago [3]

The blades of the Chicago unit were made from drawn copper where the steam was superheated and brass where the steam was wet. In 1905, thin-tipping had been introduced to minimise damage if any rubbing occurred and this was applied here.

During tests, the steam consumption was 4.74 kg/kWh, setting a new record which corresponded with a cycle efficiency of 25.68%. Commonwealth Edison was very pleased with both the performance and behaviour of the machine. In the late 1930s, the unit was still in service and was fondly referred to as 'Old Reliability'.

Also in 1912, Parsons manufactured a geared cross-compound TG rated at 4.5 MW for the Pilkington glass company in St Helens. In this machine, the HP and LP turbine were arranged side by side running at 2,400 revs/min each driving three separate DC generators mounted in tandem on a common generator shaft at 370 revs/min via gearing, fig.42.

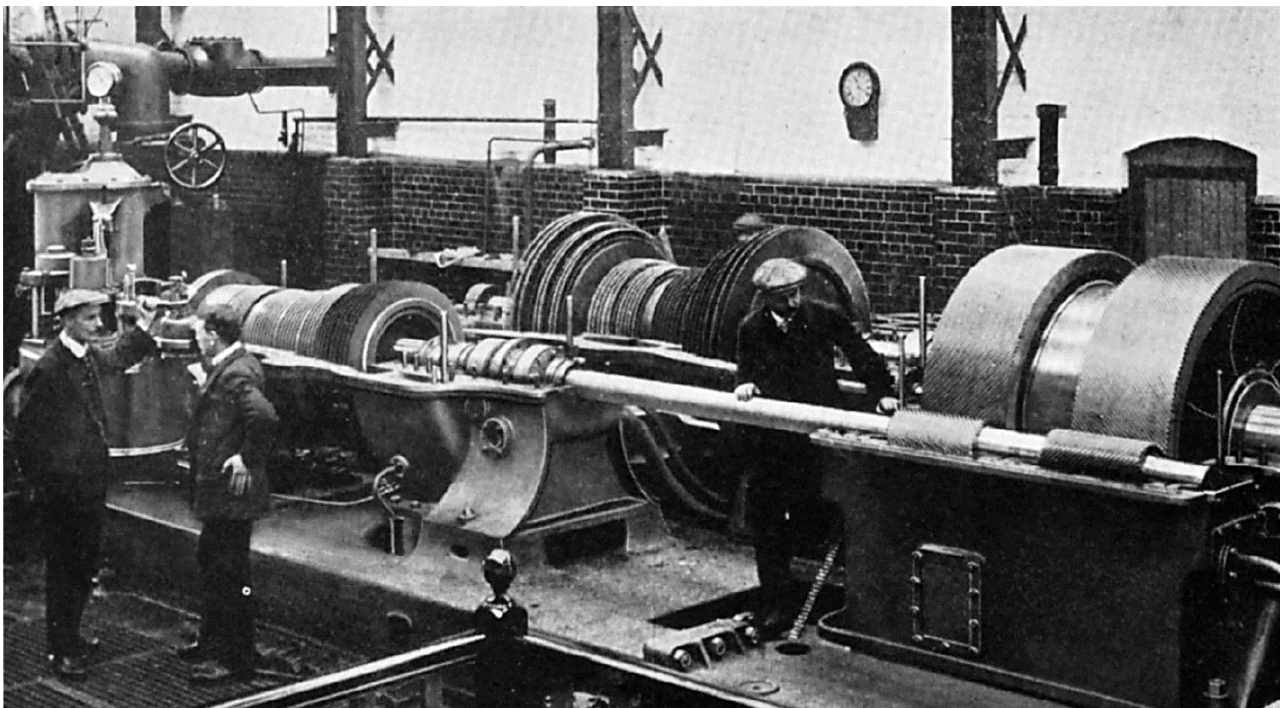

Fig.42 Pilkington 4.5 MW geared cross-compound turbine 1912 [3]

The Pilkington machine did not push the limits of TG technology but it included the first use of 'end-tightened' blades, fig.43, which was a key feature of Parsons turbines - this would be used until the 1970s with great effect.

For most of the 20th century, power generation engineers were concerned about turbine casing distortion because it couldn't be calculated reliably before suitable computer models and 3D finite element analysis became available. Until then, people used every technique possible to measure casing movements and estimate stresses and strains eg strain gauges were used during water testing and in service, photo-elastic models were made, etc as each technique became available. Design engineers identified casing geometries which were known to have good deflection behaviour, and even with this, they preferred to avoid having tight radial seal clearances in case rubbing occurred. In impulse turbines, often there were no radial seals on the moving blades justified on the basis that most of the pressure drop occurred across the diaphragms (fixed blades). In reaction turbines, seals could not be omitted from any blade row, but a similar result was achieved by adopting end tightened blades which had only axial sealing fins and no radial seals, fig.43.

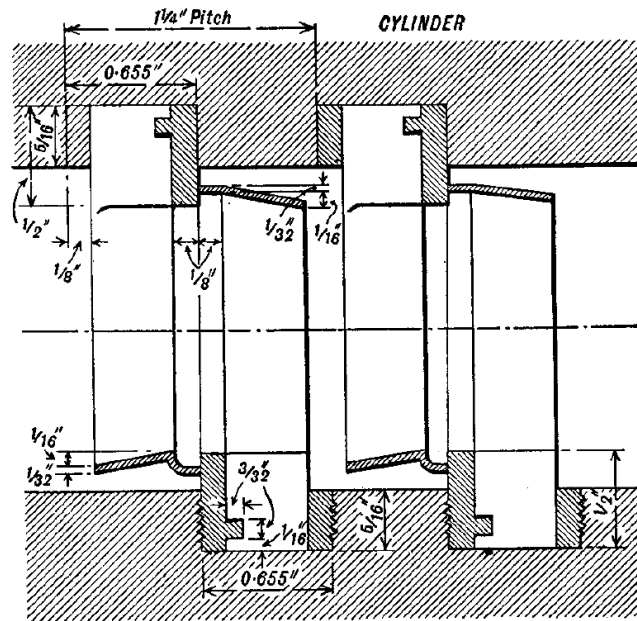

Fig.43 The earliest end-tightened blading [3]

Since the axial seals could operate with much tighter clearances than any practicable radial seal, these axial sealing fins could control the tip leakage rate effectively. On the Pilkington machine, the efficiency gain was around 4 to 5% compared with radial clearance blades, and it became very rare for blading to be stripped off due to contact. To minimise wear, Parsons provided a thrust bearing on each turbine shaft; the bearing on the HP turbine shaft could be moved in service to open the axial clearances during start-up or before a large load change, and then the clearances could be closed again once the machine was fully heated. Claw couplings allowed each shaft to move independently. Any wear could now be corrected by moving the shaft to restore the design clearances even as the machines grew old. Hollow and stub rotor construction matched the thicknesses of the shaft and casing approximately and so minimised differential axial expansion along the blade path. Together with the use of reaction blading, this led to Parsons turbines achieving and sustaining high efficiencies.

End tightening was used in the HP blade path, with laced, radial clearance blades in downstream stages where the tip leakage rate was naturally low and where it was desirable to eject water from the blade path by centrifugal action.

In 1913, a more highly rated version of the Chicago unit was supplied to Lots Road, figs.44 and 45. This machine operated at 15 MW economic load, 18 MW normal full load with a maximum capability of 22.5 MW. Since the London Underground operated at 33.3 Hz, the turbine ran at 1,000 revs/min. Using dynamic scaling to compare with the Chicago unit (25 MW at 750 revs/min), the rating of the Lots Road set was dynamically equivalent to 40 MW at 750 revs/min. The higher rating combined with the smaller diameters needed at the higher speed changed the construction of the machine. The HP turbine rotor was now a solid monobloc forged shaft (with bolted on discs for the dummy piston) and the LP turbine shaft was manufactured using discs shrunk on to a central pencil shaft.

In addition, Lots Road used a tilting pad thrust bearing. This bearing type was invented in 1905 by AGM Michell in Newcastle (and simultaneously by Albert Kingsbury in the USA). The Michell design became known to Parsons and was quickly adopted. Confidence in the bearing was high enough to use it on the Lots Road machine. In this case, the bearing was installed in a fixed seat but on subsequent machines it was soon provided with a means to vary its axial position in service so it

could be used with end tightened blades. The Michell bearing was studied by many engineers and the principle of using the shaft speed to develop a hydrodynamic oil film so that the shaft did not come into contact with the stationary parts in service became understood. This led to journal bearings which used the same principle.

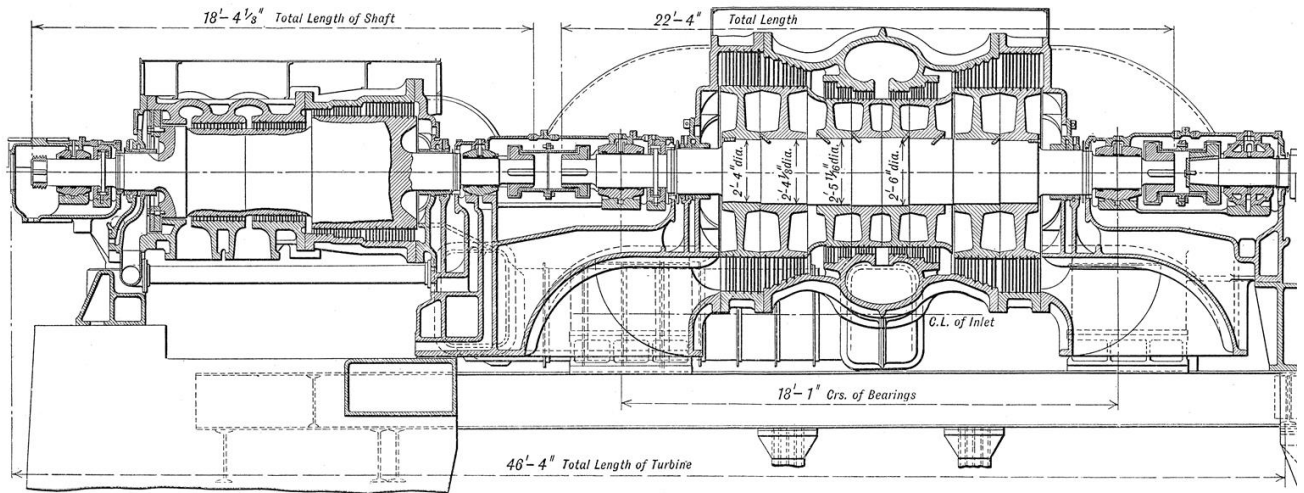

Fig.44 Lots Road turbine with a maximum capability of 22.5 MW at 1,000 revs/min 1913 [3]

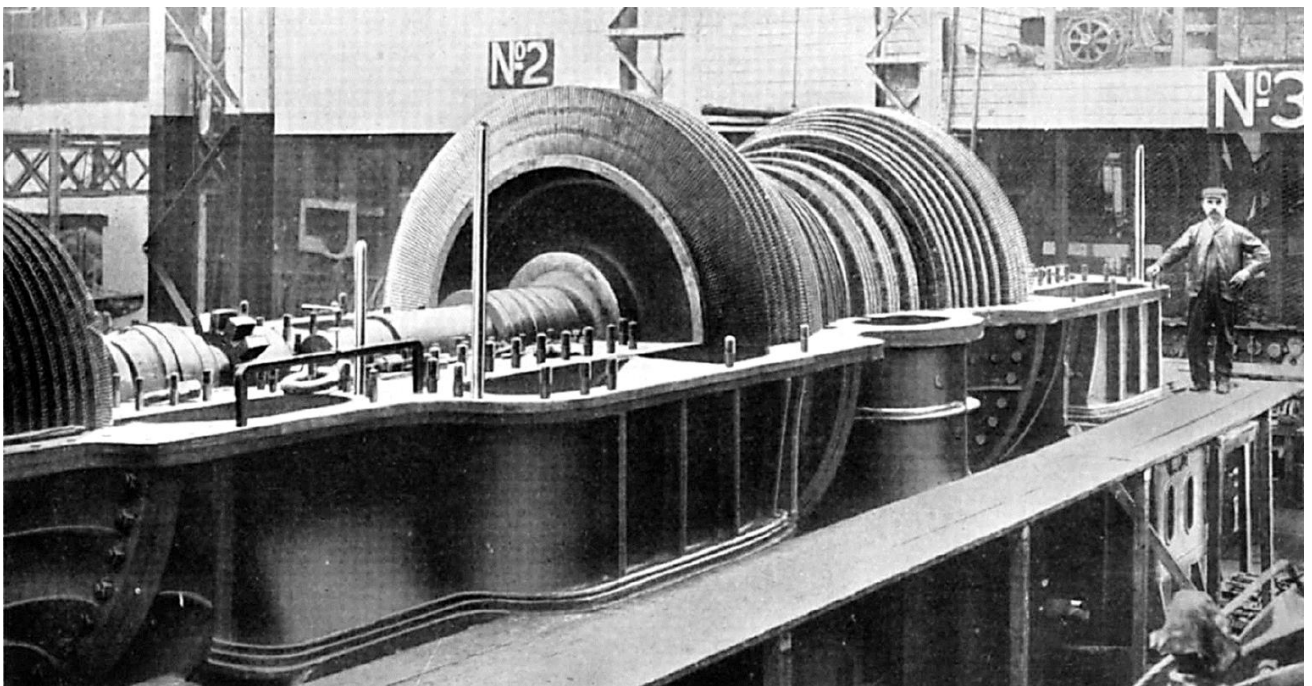

Fig.45 Lots Road LP turbine

So, by 1913, the principal features which became common to nearly all large Parsons steam turbines for the next 50 years had emerged:

- Generally a single line, tandem compound machine would be used, but cross-compounding could be employed if there was a special reason.
- The units used predominantly reaction blading for high efficiency with end tightening in the HP turbine to give an advantage.
- HP turbine shafts were either solid monobloc forgings or hollow-and-stub construction.
- LP turbine shafts were monobloc for small sizes and disc construction for larger units.
- In two cylinder machines, the LP turbine was double flow.

- Either bypass governing or nozzle governing was used to minimise valve throttling losses at part load. This also allowed machines to pick up load quickly if another generating set suddenly broke down in the days before the National Grid provided spare capacity.

The blades were made from copper and brass. In time, these would be superseded by stainless steel but this material was only just being developed for the first time in Sheffield in 1913 and was not yet available.

In 1914, Carville B power station was constructed in Newcastle-Upon-Tyne. Here, the steam conditions were raised to 250 lbs/ins² 706°F (17.2 barg 374°C). Five 11 MW units running at 2,400 revs/min were installed, fig.46. This output was far higher than had been contemplated previously at this speed (dynamically equivalent to 63.4 MW at 1,000 revs/min when compared with Lots Road or 112.6 MW at 750 revs/min when compared with the Fisk Street machine).

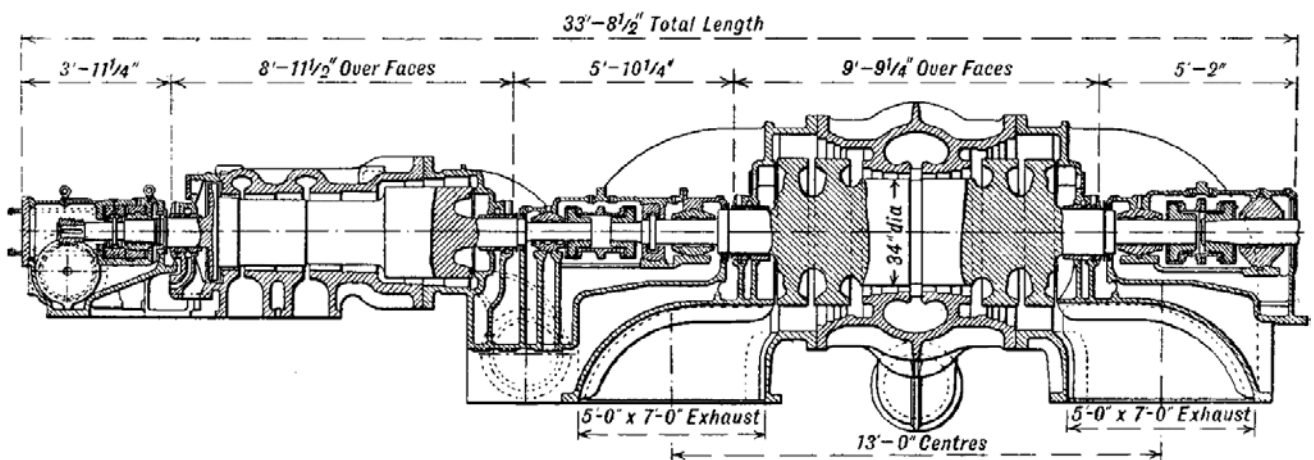

Fig.46 Cross-section through a Carville B turbine 11 MW at 2,400 revs/min 1914 [3]

The greatest challenge was the generator design, with a power factor of 0.75 and a requirement to withstand 25% overspeed, this was rated at 14.7 kVA with a maximum speed of 3,000 revs/min. Industry experts thought that this was impossible to design. Keeping to the established limit on surface speed, the generator shaft had to be twice as long as previous designs. Satisfactory rotor dynamics behaviour was proven by spinning a 12th scale shaft forging at speeds up to 36,000 revs/min. In addition, a new form of rotor cooling had to be developed. Details are given in [3].

For the turbine, the high speed allowed monobloc forgings to be used for both the HP and LP shafts. In the LP turbine rotor, care was taken to profile the integrally formed discs to reduce stresses. Bypass governing was retained in the HP turbine except that at the higher steam conditions, it was decided to mount the inlet valves in separate steam chests off the turbine to minimise the risk of distortion in the main casing.

Reheat was applied to one of the units at the station, using a tubed heat exchanger fed with live steam from the main steam range. The HP turbine exhaust steam temperature was raised from 158°C to 207.6°C. The pressure drop over the reheater was 17 mbar ie 2.2% of the absolute pressure. The improvement in heat rate was 0.515%.

The units produced excellent performance and the station was reported to be the most efficient power plant in the World for several years [3]. However, there were some teething issues due to the higher temperature as follows:

- The lengths of the shroud sections fitted to the end tightened blades were very long. As the shrouds heated up ahead of the blades, they expanded circumferentially placing the blades at the end of each section in bending, which reversed on each start-stop cycle. The blades failed due to low cycle fatigue and shorter shroud sections had to be fitted.
- The blades in the HP turbine were made from manganese copper which had a substantially different coefficient of expansion to the carbon steel rotor and casing. Blades started to work their way out of the grooves. It was decided to use mild steel for the high temperature section and to assemble the blades in shorter segments with expansion gaps.
- The brass strips which formed the dummy piston seals also started to move out of their grooves due to differential expansion. This was solved by using shorter strips with controlled expansion gaps.
- The pipes which routed the dummy piston leakage steam back into the blade path had to be made more flexible.

In addition, the use of 70/30 brass for the last stage LP turbine blades limited their length to around 8" (203.2 mm) which resulted in leaving losses equal to around 6% of the available energy from the steam, twice that which might otherwise have been achieved. Consequently, the blades were later changed to a mild steel design.

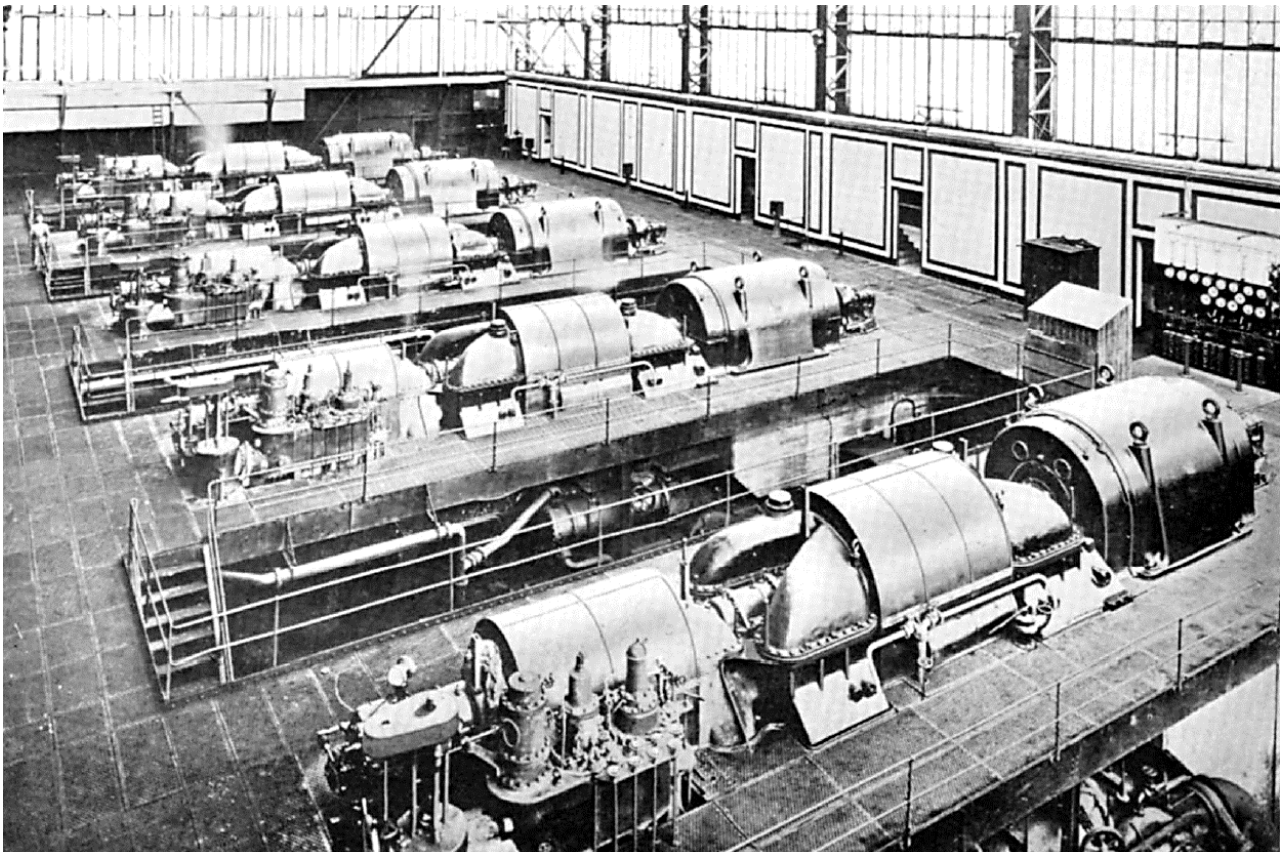
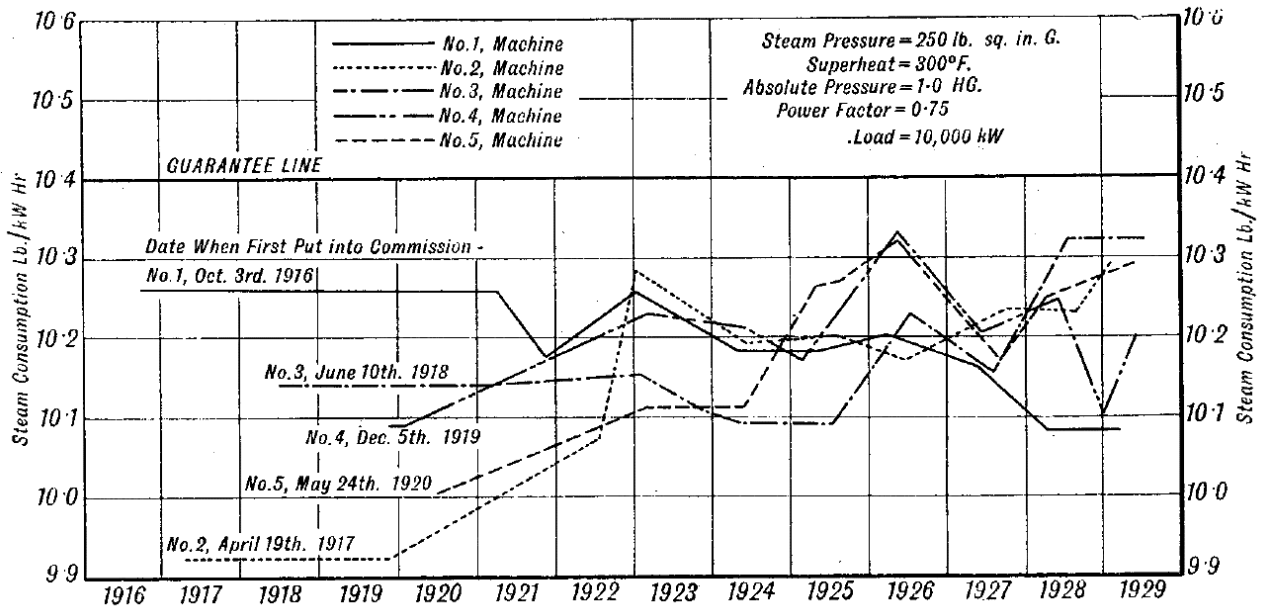

Fig.47 Five 11MW 2,400 revs/min TG sets in Carville B [3]

The advantages of the end tightened blades were clearly demonstrated from performance measurements over the life of the plant, fig.48. These 40 Hz units operated from 1916 until 1931 when the National Grid required all UK power stations to change to 50 Hz or to close. As may be seen, the performance of most of the units barely changed over this 15 year period.



	When put into commission.	Total hours run.								
		1919-20-21.	1922.	1923.	1924.	1925.	1926.	1927.	1928.	1929.
No. 1	October 3rd, 1916	26,297	—	31,202	38,772	44,610	48,883	55,206	61,305	67,185
" 2	April 19th, 1917	12,824	26,825	29,960	37,641	43,685	49,141	54,960	60,120	65,240
" 3	June 10th, 1918	14,500	—	26,978	33,469	39,414	44,836	50,413	55,040	60,057
" 4	December 5th, 1919	427	—	19,866	27,521	34,292	37,213	43,174	49,006	54,397
" 5	May 24th, 1920	400	—	15,960	23,313	27,848	34,071	39,975	44,101	49,567

Fig.48 Performance measurements over the life of the 40 Hz turbines at Carville B. The guaranteed steam consumption of the machines was 10.4 lbs/kWh. All units performed better than this at all times. [3]

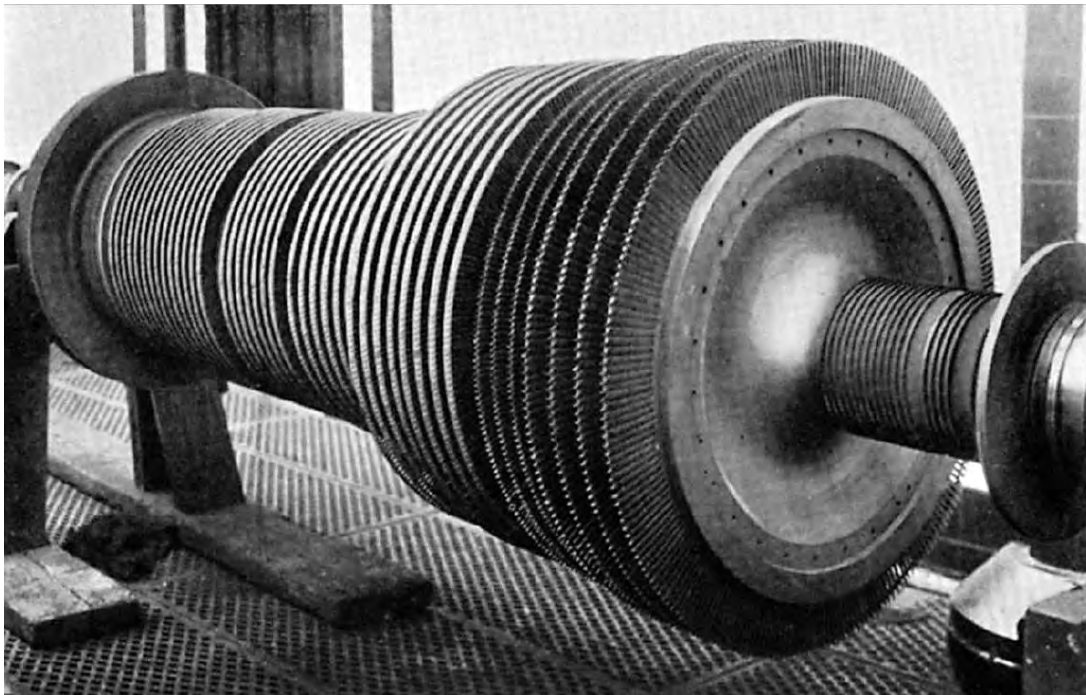

Fig.49 Carville B HP turbine rotor [3]. The extent of the end tightened blades is evident from the blade shrouds.

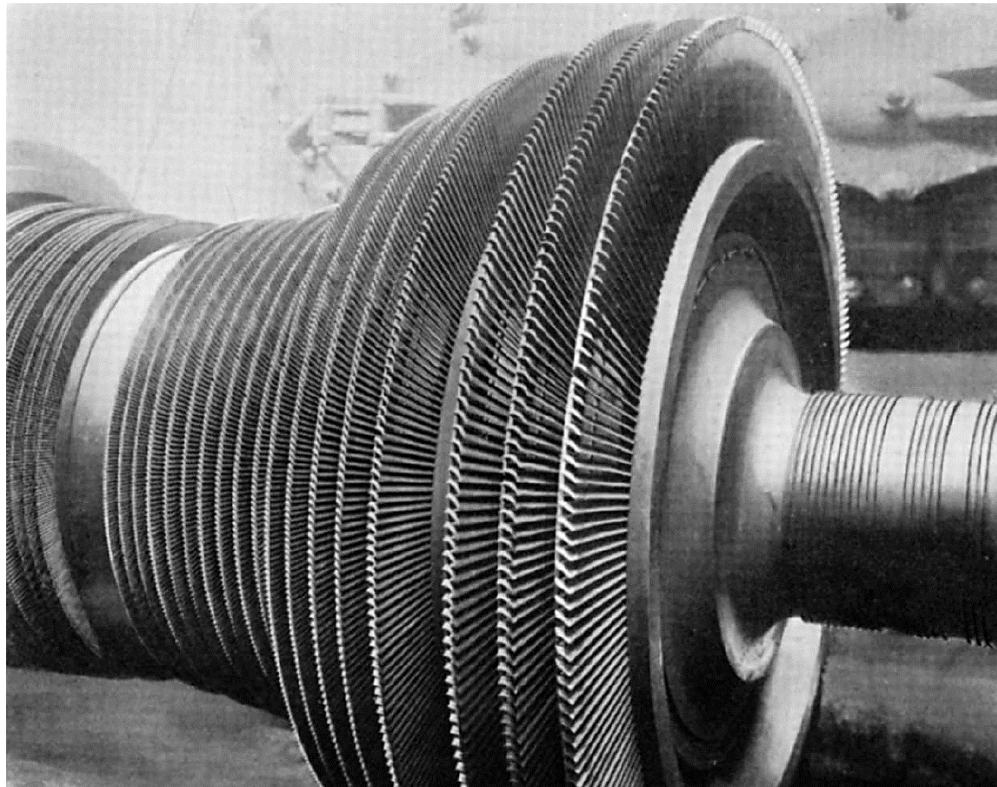

Fig.50 One flow of a Carville B LP turbine rotor showing the short last stage blades [3].

In 1916, Parsons built a 3 MW geared cross-compound unit for the Blaydon Burn waste heat station of the Priestman Power Co. on the west side of Newcastle. This was the first turbine-generator ever to use feedwater heating. Two heat exchangers were used which took steam from the HP turbine exhaust and from part way along the LP blade path, figs 51 & 52.

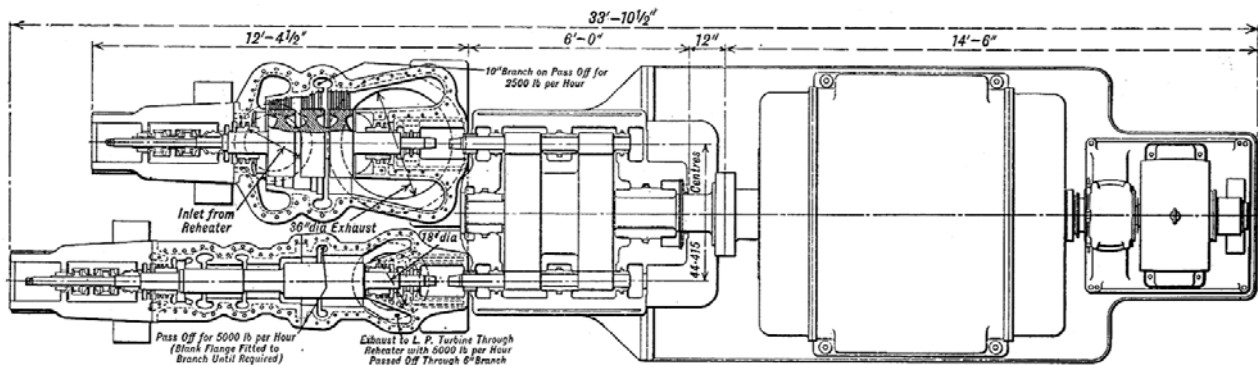

Fig.51 Plan view of the 3 MW Blaydon Burn turbine-generator. The first steam TG in the World to use regenerative feedwater heating [3]. The shafts speeds were HP turbine 5,000 revs/min, LP turbine 4,200 revs/min and generator 800 revs/min.

The steam conditions were 190 lbs/in² gauge 600°F (13.1 barg 316°C) at HP inlet, 23.5 lbs/in² abs 281°F (1.6 bara 138°C) at HP exhaust with reheating to 400°F (204°C) at LP inlet. No dummy pistons were used; instead, the axial end thrust was carried by two thrust bearings per shaft. The HP shaft was so narrow, one engineer at Heaton Works called it “a piece of bladed wire”. The generator was the first to be cooled using a closed air circuit. Boiler feedwater passed through the generator air cooler to absorb heat before being routed to the two feedheaters.

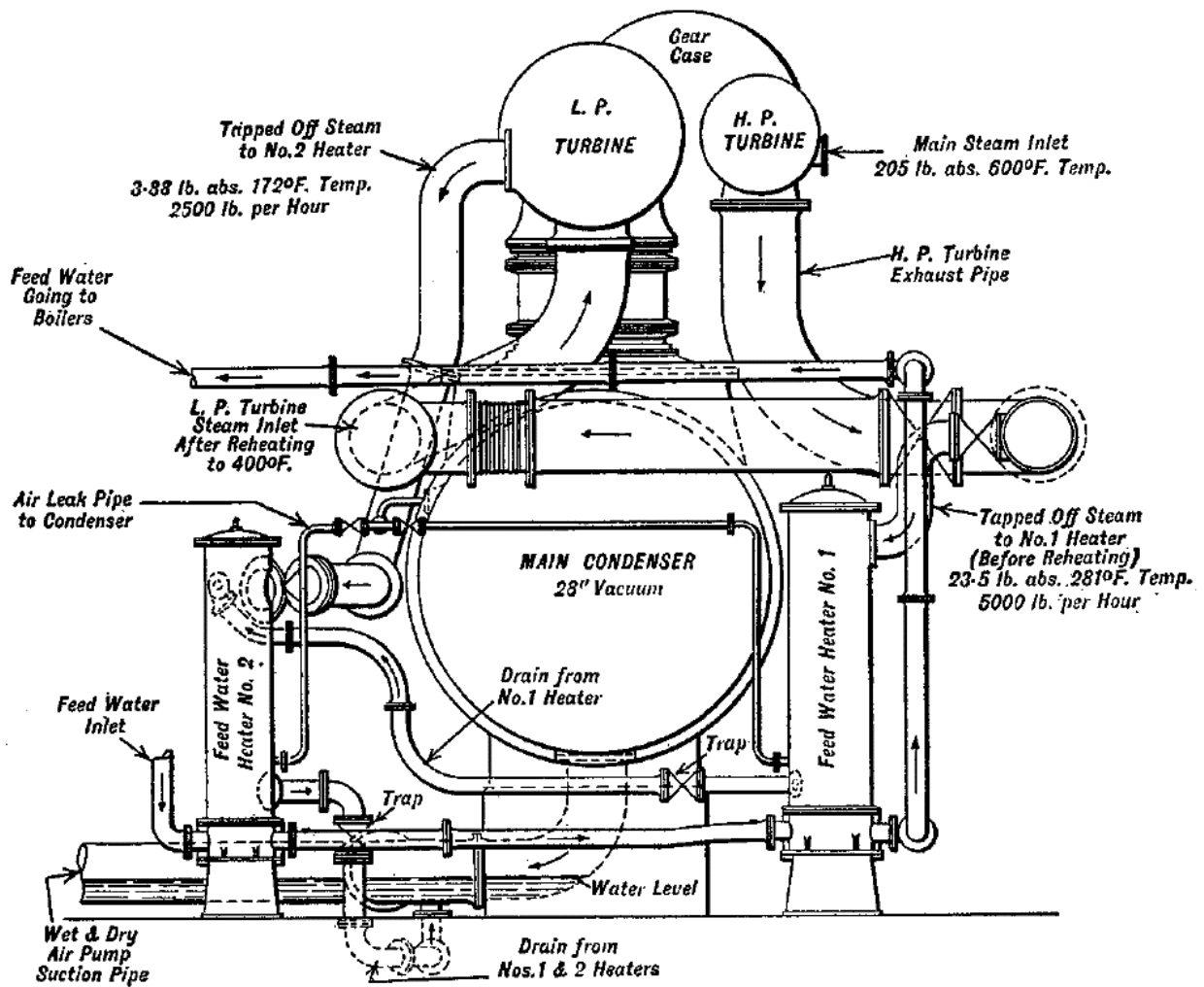

Fig.52 End view of the Blaydon Burn plant arrangement [3]

Between 1913 and 1922, single cylinder and two cylinder single shaft machines were the main focus of development.

The key steps in Parsons single cylinder turbine evolution in this period may be summarised as follows:

Year	MW rating	Speed revs/min	Station	Comments
1913	3 MW	3,000	Norwich PS	Parsons first 3,000 revs/min single cylinder turbine
1916	4 MW	3,000	Derby PS	
1917	15 MW	1,500	Bradford PS	Dynamically equivalent to 3.75 MW at 3,000 revs/min
1917	5 MW	3,000	Aberdeen PS	
1918	7.5 MW	3,000	Hackney PS	
1920	10 MW	3,000	Hammersmith PS	
1921	18.75 MW	1,500	Treforest PS	Equivalent to 4.7 MW at 3,000 revs/min
1922	21 MW	1,500	Dalmarnock PS	Equivalent to 5.25 MW at 3,000 revs/min

Table 1 Parsons most highly rated single cylinder turbines 1913 to 1923 [3]

The 1,500 revs/min units were amongst the largest single cylinder turbines running at this speed anywhere. They were physically huge using shrunk disc construction to achieve the required shaft diameters, fig.53. The 3,000 revs/min designs could use solid, monobloc forged rotors, fig.54, and were the more challenging to design. For the 7.5 MW Hackney turbine, the last stage blade material was changed to Monel metal, which was a NiCu alloy containing 65 to 70% nickel and 26 to 30% copper.

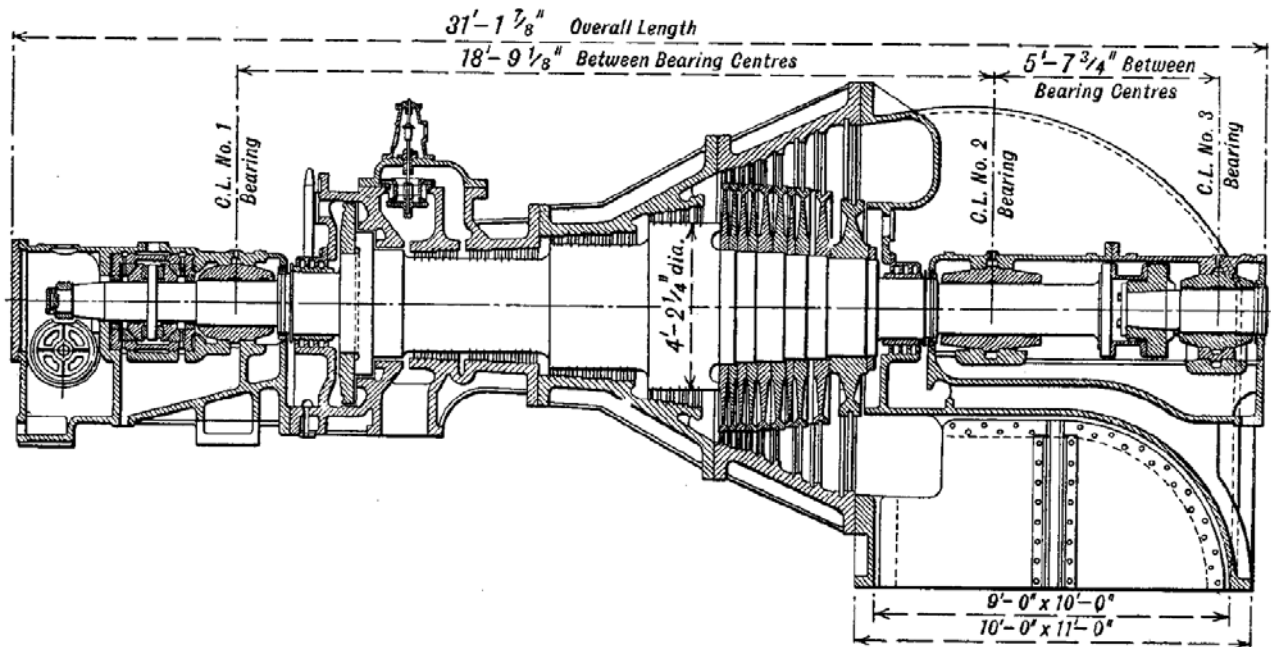

Fig.53 An example of a large 1,500 revs/min Parsons single cylinder turbine with a shrunk disc construction rotor, 18.75 MW Treforest 1921. The bladed rotor weighed 36 tons. The LP blade path now used an almost smooth, conical outer flow boundary with blades of progressively increasing height rather than being stepped with groups of blades of the same height [3].

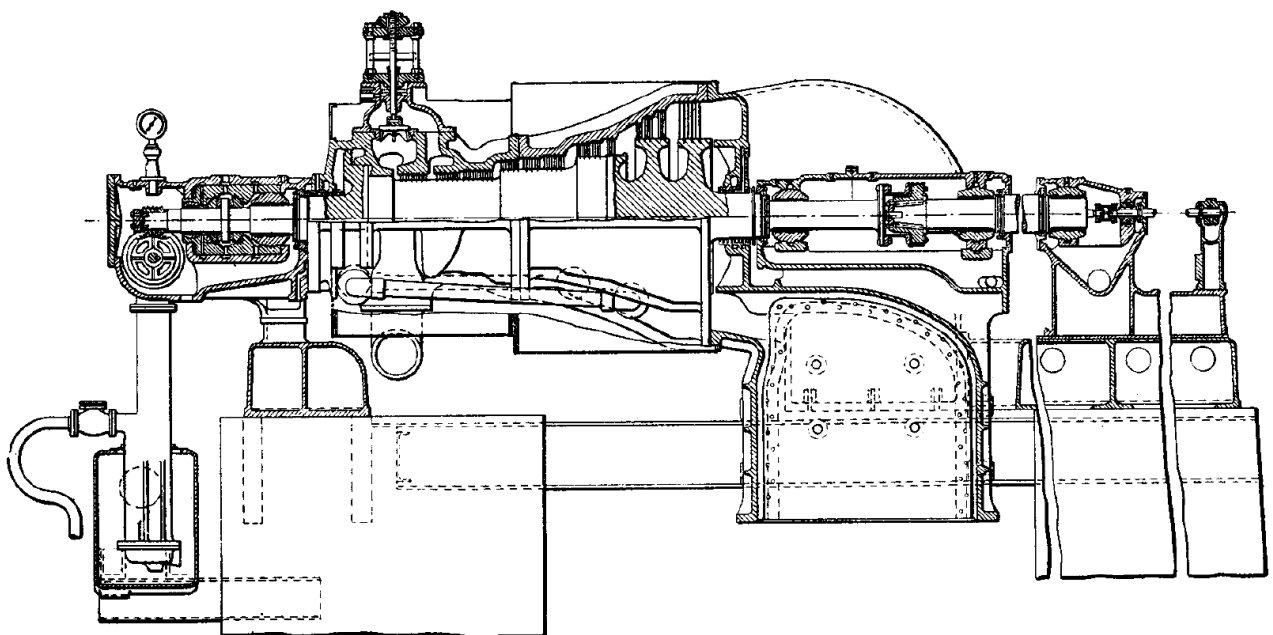

Fig.54 An example of a large 3,000 revs/min Parsons single cylinder turbine with a monobloc forged rotor, 7.5 MW Hackney PS 1918 [3]

Up until this time, blades were untwisted with a constant cross-section. In 1919, a 5 MW turbine was designed for Bankside PS in London in which the ratio of blade height to shaft diameter was 1:2.25. These were the first blades made by Parsons in which the aerofoils were tapered and twisted along their length. Together with the use of mild steel, this allowed the length of the last stage blades to increase. Last stage blades running at 3,000 revs/min increased from 6.5” (165.1 mm) on a shaft diameter of 25.5” (647.7 mm) in 1913 to 14.5” (368.3 mm) on a shaft diameter of 35.5” (901.7 mm) in 1920.

The corresponding steps in the development of two cylinder, tandem compound machines may be summarised as follows:

Year	MW rating	Speed revs/min	Station	Comments
1914	11 MW	2,400	Carville B PS	
1918	15 MW	2,400	Dunston A PS	
1919	18 MW	2,000	Lots Road PS	Twice the running speed of the previous Lots Road machines.
1919	12.5 MW	3,000	Mersey Power Co	Parsons first 3,000 revs/min tandem compound machines
1922	20 MW	3,000	Barking PS	

Table 2 Parsons most highly rated two cylinder, tandem compound turbines 1914 to 1922 [3]

The Dunston A turbines, fig.55, were a substantial increase in rating from Carville B, but the machines used the same casing casting patterns. Where Carville B LP turbines employed 8” (203.2 mm) tall last stage LP blades made from 70/30 brass mounted on a shaft diameter of 47” (1.2 m), the Dunston A units used blades 10.5” (266.7 mm) tall made from mild steel on a reduced diameter of 42” (1.07 m) to fit in the same casing.

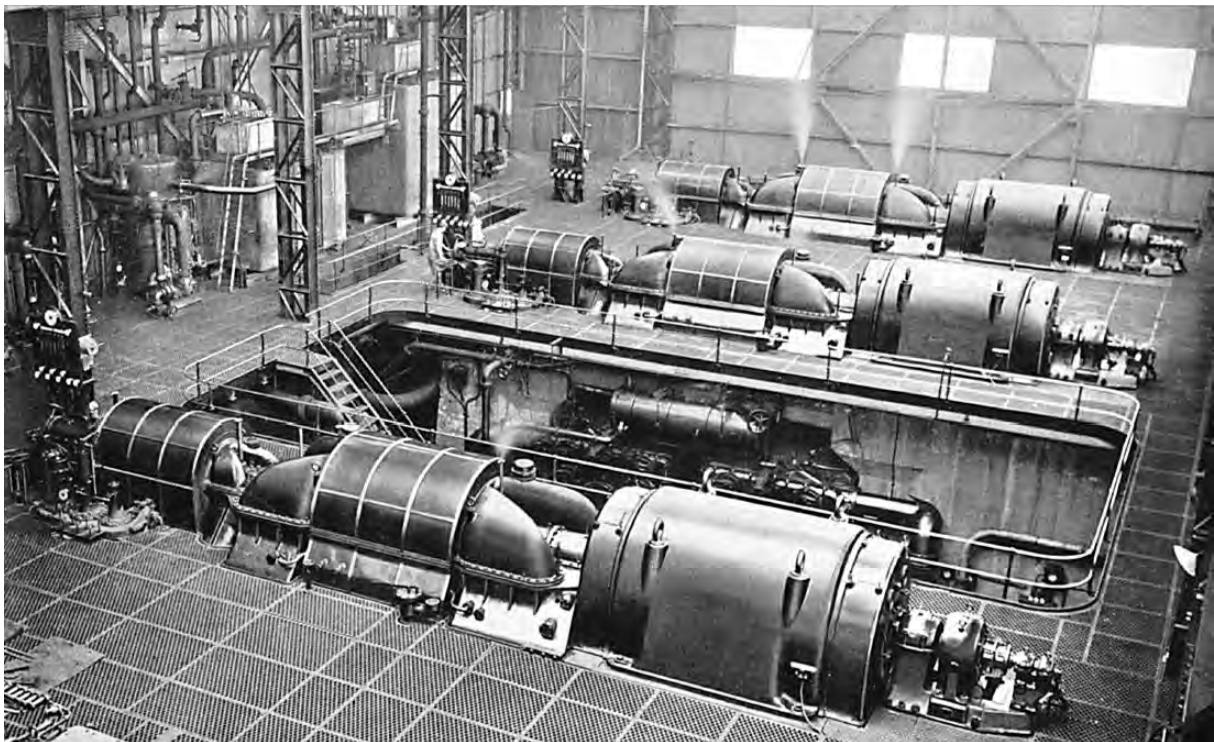

Fig.55 Three 15 MW 2,400 revs/min TG sets installed at Dunston A [3]
Both Dunston and Carville power stations were located close to Newcastle-Upon-Tyne and were operated by the same company NESCO.

Parsons first 3,000 revs/min tandem compound turbines were manufactured in 1919 for the Mersey Power Co, figs. 56 and 57. These were 12.5 MW units dynamically equivalent to 19.5 MW at 2,400 revs/min ie rated substantially higher than Carville B or Dunston A, but with a similar construction: end tightened blades in the HP turbine, monobloc forged rotors with profiling of the LP turbine rotor to reduce stress, etc. Steam conditions were 250 lbs/in² gauge 650°F (17.2 barg 343°C). The HP turbine rotor and casing were made from carbon steel. The LP turbine inlet pressure was reduced from 24 lbs/in² abs (1.66 bara) used at Carville B to 12 lbs/in² abs (0.83 bara) at Mersey Power. This ensured that the LP inlet stages were sufficiently tall and it transferred some stages to the HP turbine which saved cost (one flow of blades not two) and gained a little performance (taller blades in a single flow), but meant that the HP turbine glands had to be packed at all times using live steam as the internal pressure was sub-atmospheric.

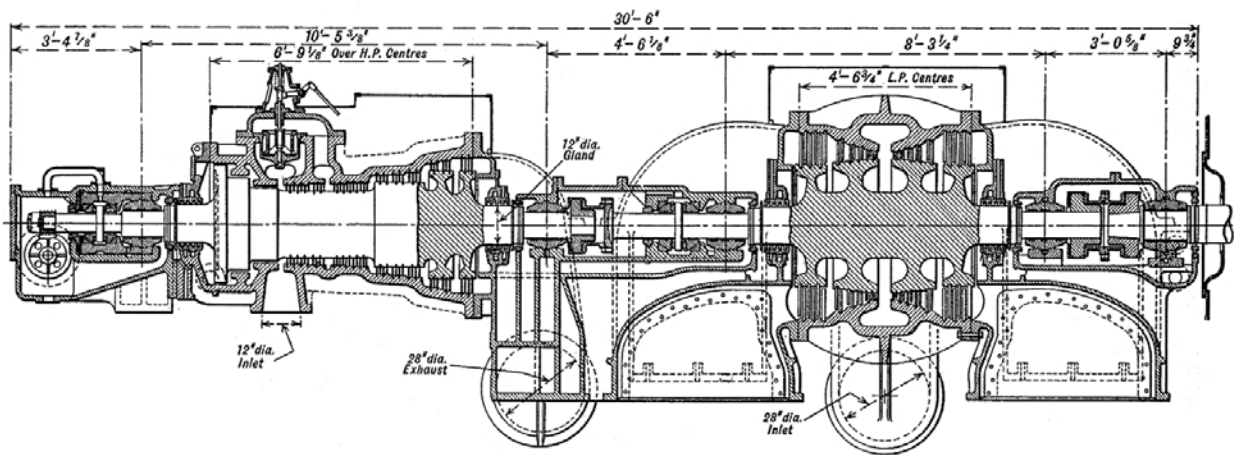

Fig.56 Cross-section through the 12.5 MW 3,000 revs/min turbine for Mersey Power Co 1919 [3]

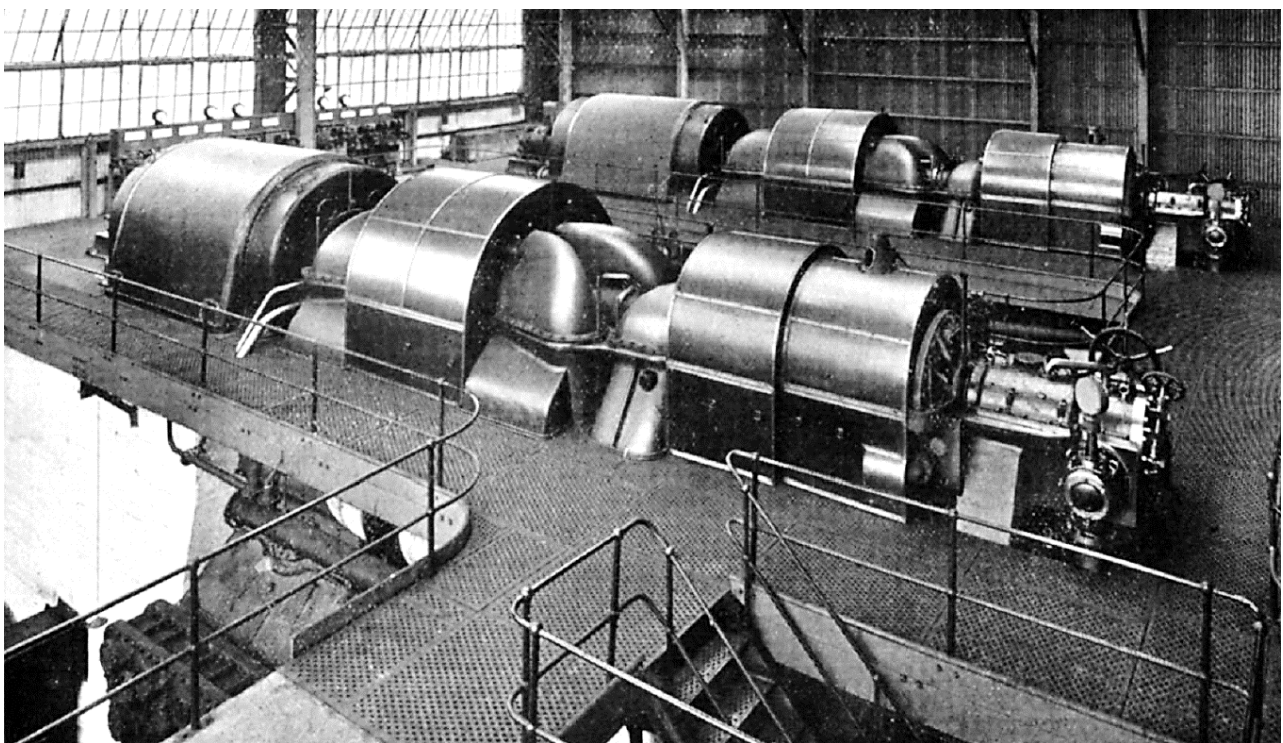

Fig.57 Two 12.5 MW 3,000 revs/min turbine-generators supplied to the Mersey Power Co [3]

In 1918, the County of London Electric Supply Co decided to build a power station which would eventually generate 600 MW at Barking. The first phase in the construction comprised two 20 MW and two 40 MW TG sets to give 120 MW, and these were ordered from Parsons. The 20 MW turbines were two cylinder, tandem compound designs of similar design to Carville B and Dunston A, but the rating of 20 MW at 3,000 revs/min (equivalent to 31.25 MW at 2,400 revs/min) was a considerable step increase.

For the 40 MW units, it was decided to use a cross-compound design with separate shafts so that the LP turbines and generators were the same as the 20 MW units, figs.58 and 59. Steam conditions were 350 lbs/in² gauge 700°F (24.1 barg 371°C) at the HP stop valve and 55 lbs/in² abs (3.8 bara) at the IP turbine inlet. On one of the units, the steam was reheated to 700°F. To accommodate the higher volumetric flow, the first blade group was omitted from the IP turbine of the reheat machine as shown in fig.58. This was the first use of reheat on a 'large' unit and the two machines were studied and compared in detail. The use of reheat reduced the steam consumption by 18% to 3.83 kg/kWh and improved the heat rate from 12,479 to 11,794 kJ/kWh, corresponding with a steam cycle efficiency of 30.5%. The units had 3 stages of feedheating.

The station was opened by King George V on 19th May 1925. A further two 20 MW and two 40 MW Parsons sets were ordered in 1926, all units having reheat. These later turbines used blade paths with conical rather than stepped flow boundaries.

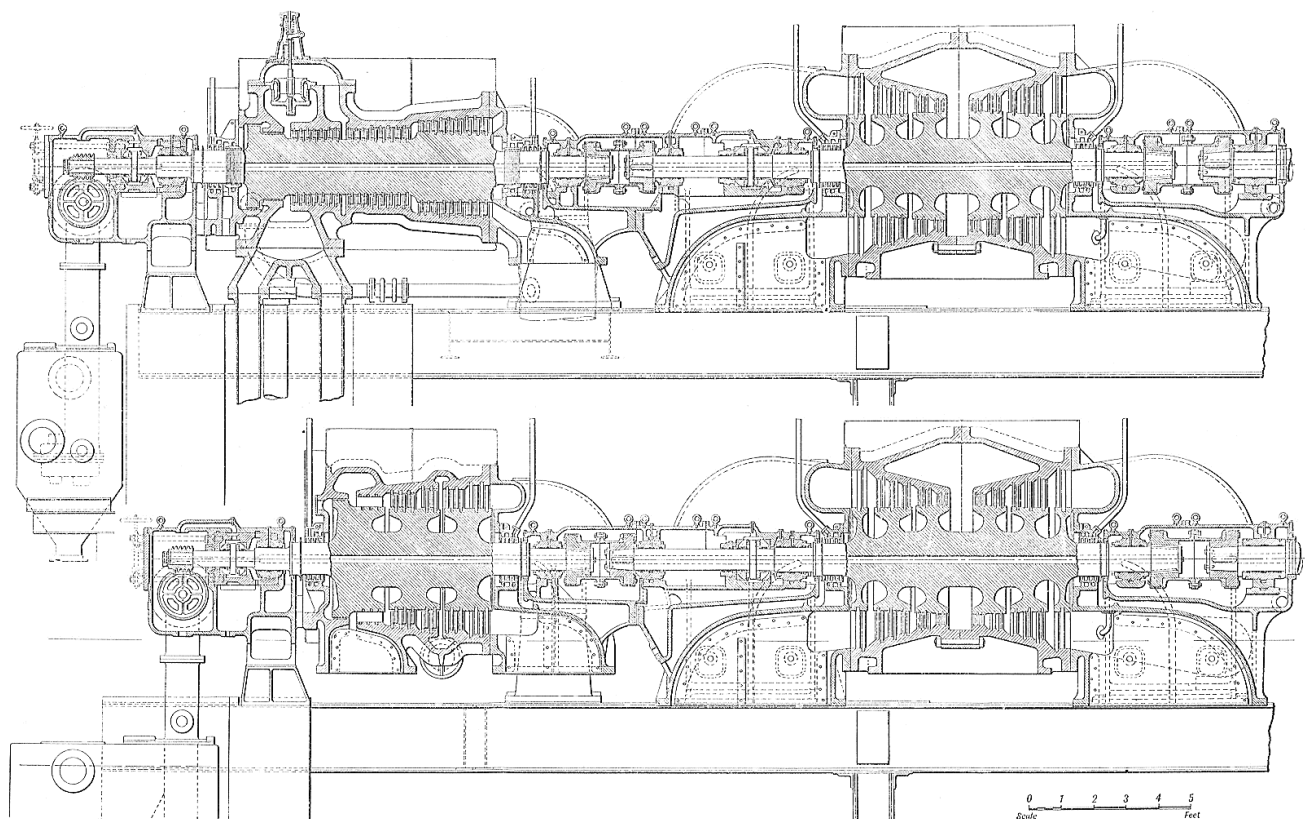

Fig.58 40 MW 3,000 revs/min cross-compound turbine for Barking PS, London 1922 [3]. The HP and LP1 turbines were located on the first line, with IP and LP2 turbines on the second. The generators of all Parsons early cross-compound machines were connected electrically just before start-up, so that the two lines ran to speed simultaneously with equal speed on each line, allowing the unit to be synchronised as if it was just a simple tandem compound machine.

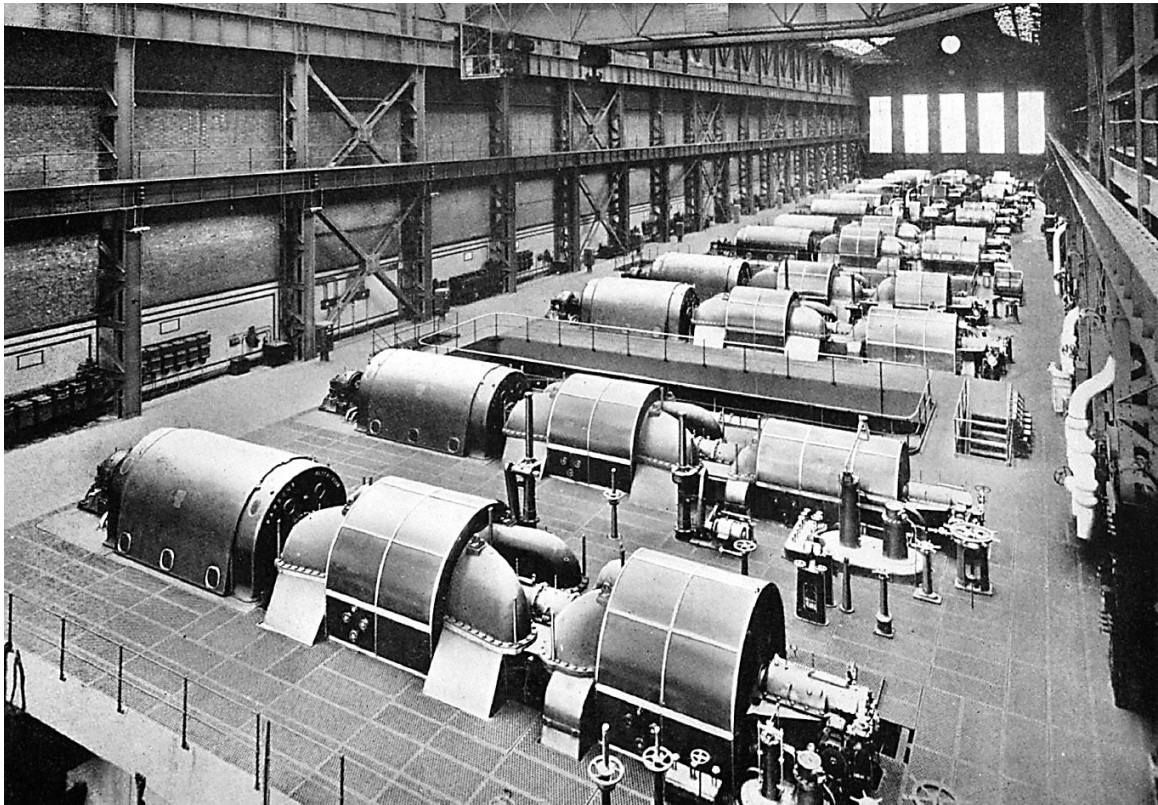

Fig.59 Barking A turbine hall showing four 40 MW cross-compound units in the foreground and four 20 MW single line units behind. [3] The 40 MW units were the largest turbine-generators operating in the UK at that time.

It was at Barking in 1925 that Sir Charles Parsons first met Claude Gibb, a young graduate trainee engineer from Australia, who was working in the UK to gain experience. Sir Charles was so impressed that he persuaded Claude to stay in England and arranged for his training and development. By 1929, Claude Gibb became Technical Director of CA Parsons & Co and by the 1940s, he was Chairman and Managing Director. Claude would cause the company to grow three-fold in size between 1945 and 1960 and initiate the rapid development of full speed machines from 50 to 550 MW in just 12 years, which will be described later.

In 1922, Samuel Insull and Commonwealth Edison Co ordered a 50 MW 60 Hz TG set for Crawford Avenue PS in Chicago. This was Parsons first 50 MW unit. Experience with the 25 MW machine at Fisk Street had been so good that no guarantees on steam consumption were required. The steam conditions were much higher than previous Parsons machines at 550 lbs/in² gauge 750°F (37.9 barg 399°C) with reheat to 700°F (371°C). It achieved a heat rate of 10,590 kJ/kWh corresponding with a cycle efficiency of 34.0% which compares with 13,984 kJ/kWh and 25.7% for the Fisk Street unit.

The turbine arrangement is shown in figs. 60 to 62. It was a cross-compound machine with an HP turbine driving a 16 MW generator at 1,800 revs/min on one line, an IP turbine driving a 29 MW generator at 1,800 revs/min and an LP turbine driving a 6 MW generator at 720 revs/min. As may be seen in fig.62, the LP turbine comprised just 5 stages of blades in one flow arranged directly in line with the discharge from the IP blading. It was originally intended that the HP and IP turbines would be mounted on the same shaft driving just one generator, with the LP turbine separate, and the whole machine looking outwardly as if it was a single line unit, but it was found that the existing building couldn't accommodate the overall length (space was reserved for further machines) so the arrangement shown in figs. 60 and 61 was adopted.

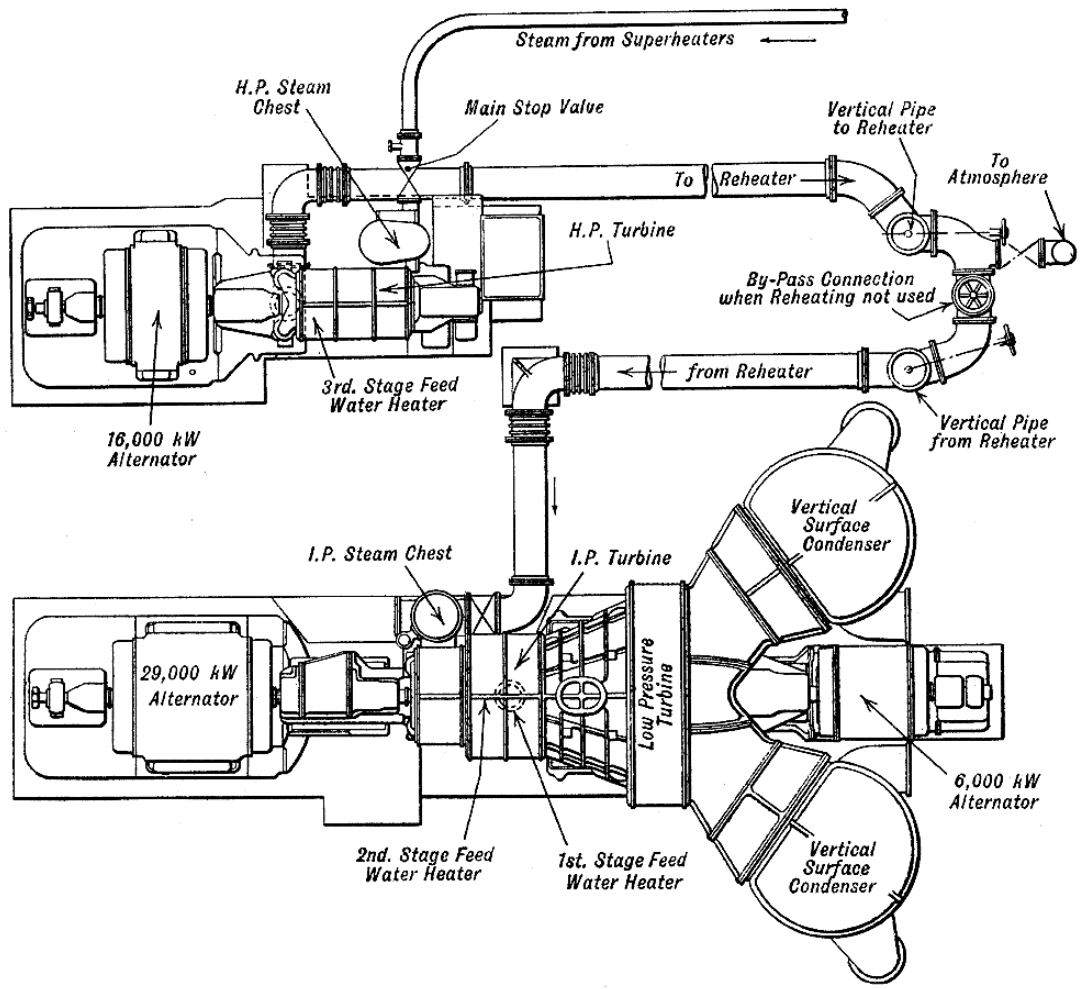

Fig.60 Arrangement of the 50 MW Crawford Avenue turbine-generator [3]

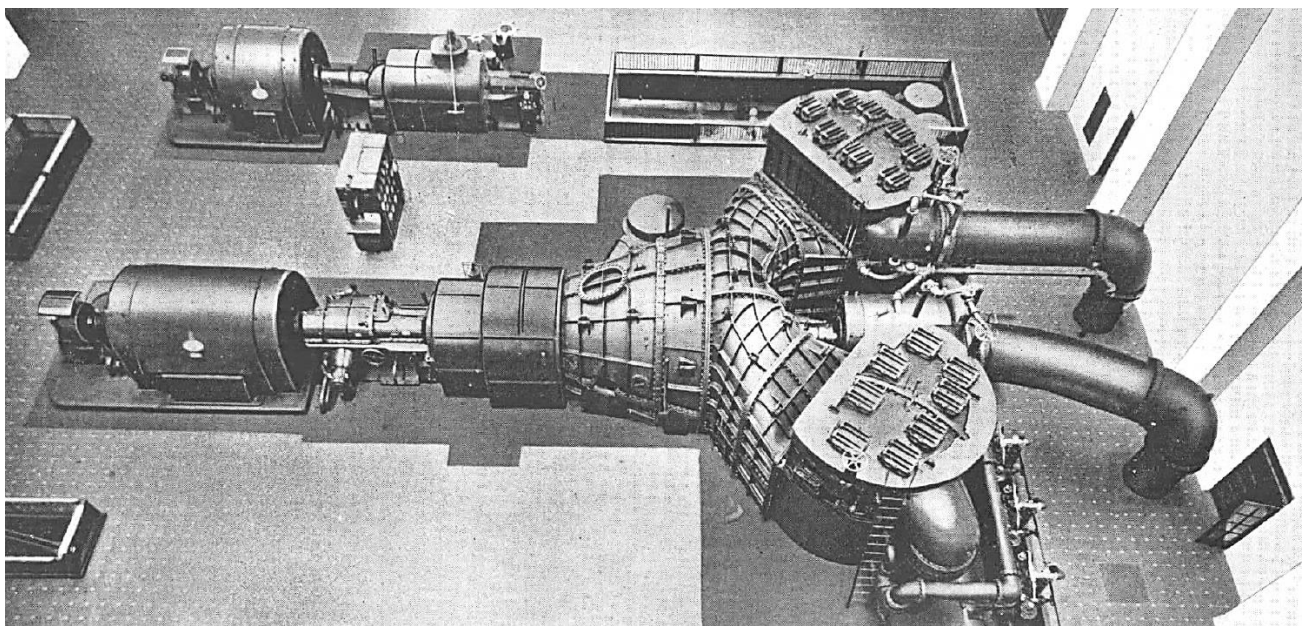

Fig.61 50 MW unit installed in Chicago 1925 [8]

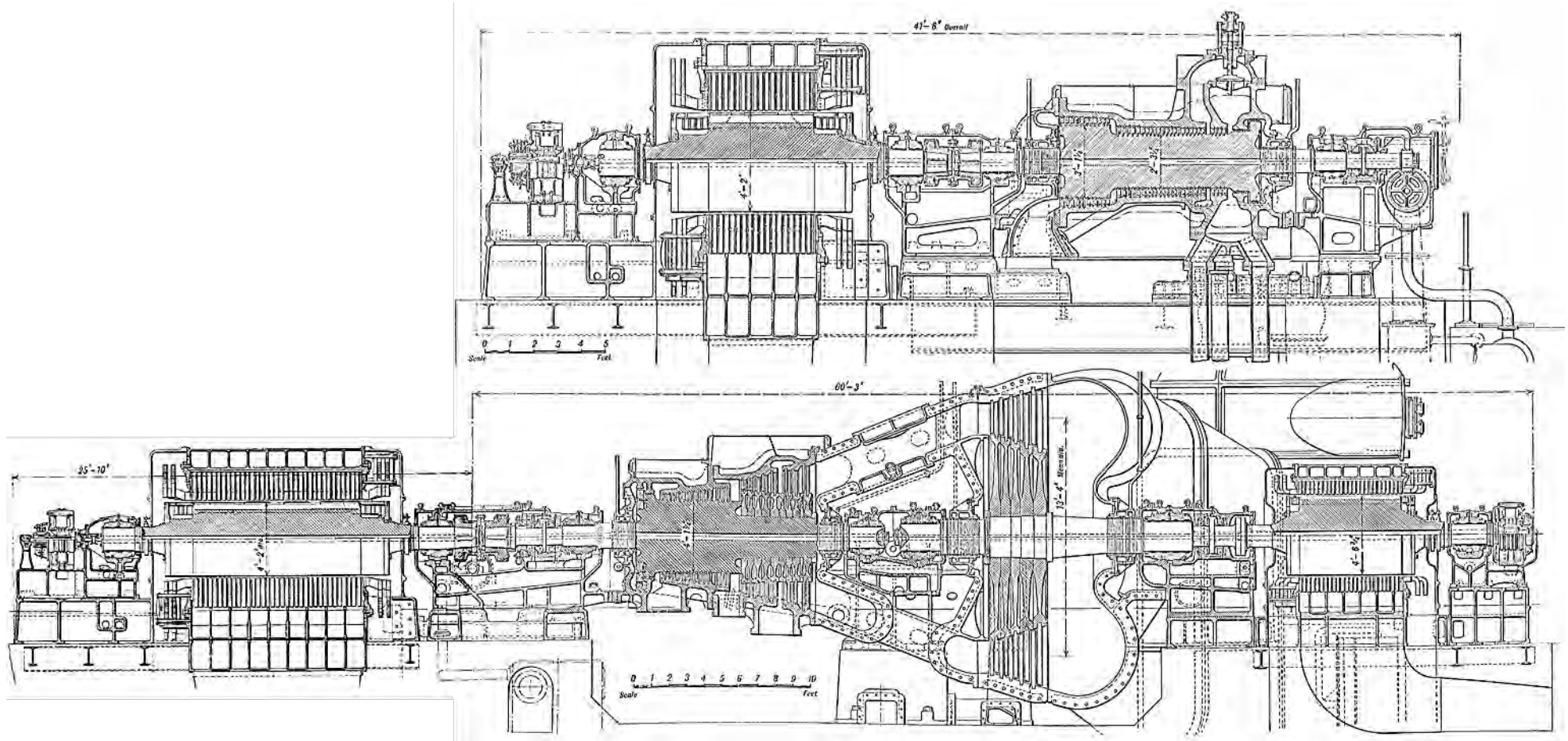

Fig.62 Cross-section through the 50 MW Crawford Avenue turbine [3]

The HP turbine was on the first line driving a 16 MW generator at 1,800 revs/min, *top*.

The IP turbine was on the *left hand side* of the second line driving a generator at 1,800 revs/min, *bottom*.

The 5 stage LP turbine was separate from the IP turbine and drove a 6 MW generator at 720 revs/min on the *right hand side* of the second line.

The high inlet pressure at Crawford Avenue normally would have required an increased stage count, but Parsons counteracted this by keeping the speeds of the HP and IP turbines high. The unit needed a large exhaust area due to the power output and the availability of low condenser pressures. By keeping the LP turbine speed down to 720 revs/min, the tip diameter of the last stage was 200" (5.08 m), the largest diameter exhaust CA Parsons & Co would ever build, with 40" (1.016 m) long blades which gave an exhaust area of 13 m², fig.63a. This compares with the Barking 40 MW sets which had a total exhaust area of just 5.76 m² even with four exhausts.

Each of the last stage blades weighed 21 lbs (9.5 kg), so it was decided to use moment-balancing to determine where each blade should be placed for best balance (ie the distribution of weight along the length of each blade was taken into account during assembly, not just the absolute weight of each blade), fig. 63b. This was the first time this was done at Parsons.

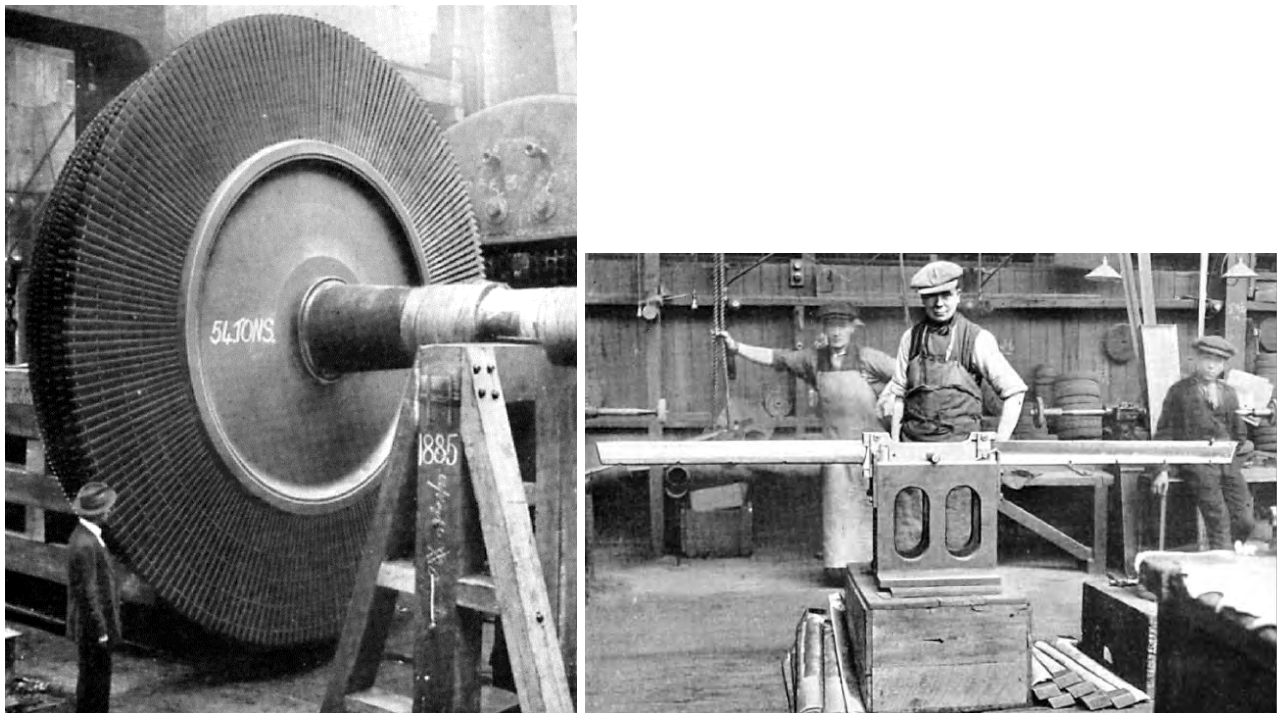

Fig.63a The assembled LP turbine rotor, *left*, and fig.63b moment balancing the Crawford Avenue last stage blades, *right* [3]

In 1922, a serious incident occurred in Shanghai which would affect the entire industry. A Parsons 20 MW 1,500 revs/min single cylinder turbine, similar to fig.53, ie a solid rotor with nine discs mounted at the exhaust end burst from heat treatment cracks (clinking) in the parent forging at 1,400 revs/min during run-up. The shaft was made from medium carbon steel with a maximum diameter of approximately 1,450 mm. This led to an industry wide investigation, and as a result:

- All future rotor forgings were provided with a central through-hole to allow inspection using a borescope (until ultrasonic inspection showed this was no longer needed for modern forgings in the 1970s).
- Overspeed testing in an armoured chamber to at least 120% rated speed before leaving the factory became mandatory.

A photograph of the Shanghai unit before it left Heaton Works is shown in fig.64.

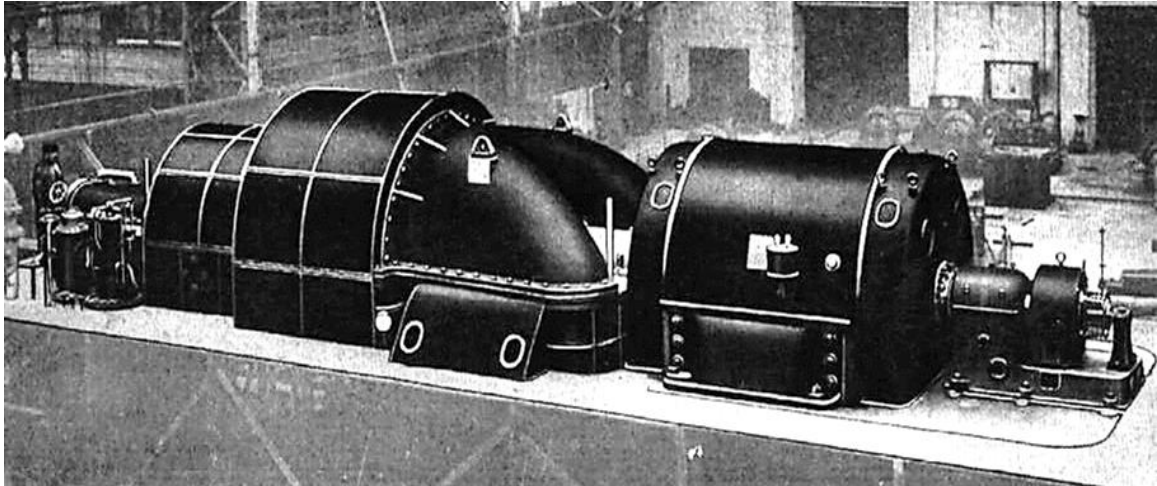

Fig.64 The 20 MW Shanghai unit assembled at Heaton Works

In 1923, a further 18 MW turbine was ordered for Lots Road. This ran at 2,000 revs/min, but with only one turbine cylinder rather than two. In this machine, the last 11 rows of moving blades were made from stainless iron. By 1925, stainless iron was used for all blading.

In 1924, a key design change occurred in a 10 MW single cylinder turbine for Derby PS, fig.65. In this machine, both the inner and outer flow path boundaries were entirely smooth and conical in nature. This became standard design practice.

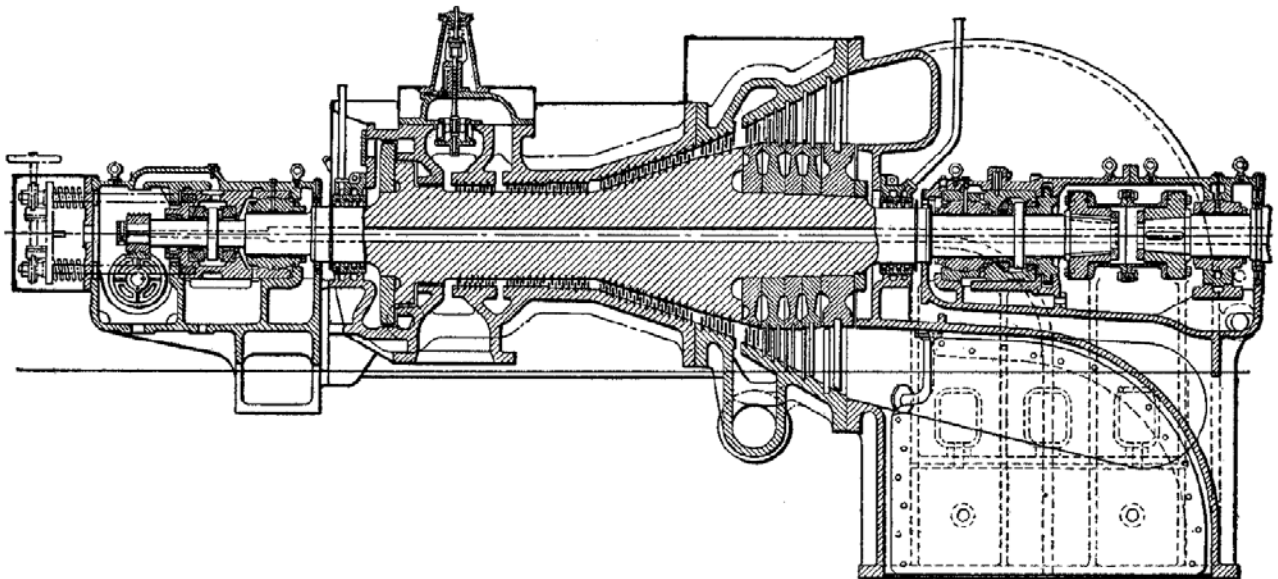

Fig.65 A 10 MW 3,000 revs/min turbine for Derby with conical flow path boundaries [3]

The cost of manufacture for single cylinder turbines was, of course, much lower than for twin cylinder machines. For this reason, in 1926, Parsons decided to increase the power output of single cylinder units by adopting a duplex exhaust, figs. 66 and 67. The first units were rated at only 12 MW at 3,000 revs/min for Congella PS in South Africa (plus an ability to operate at 20 MW for 2 minutes), but much larger units were to follow. Steam conditions were 250 lbs/in² gauge 700°F (17.2 barg 371°C) non-reheat. The bladepaths were fully conical and made from stainless iron. End tightening was used in the first 28 stages. The shaft was a carbon steel, bored monobloc forging. The machine was 2.6 m (28%) shorter than a comparable twin cylinder design.

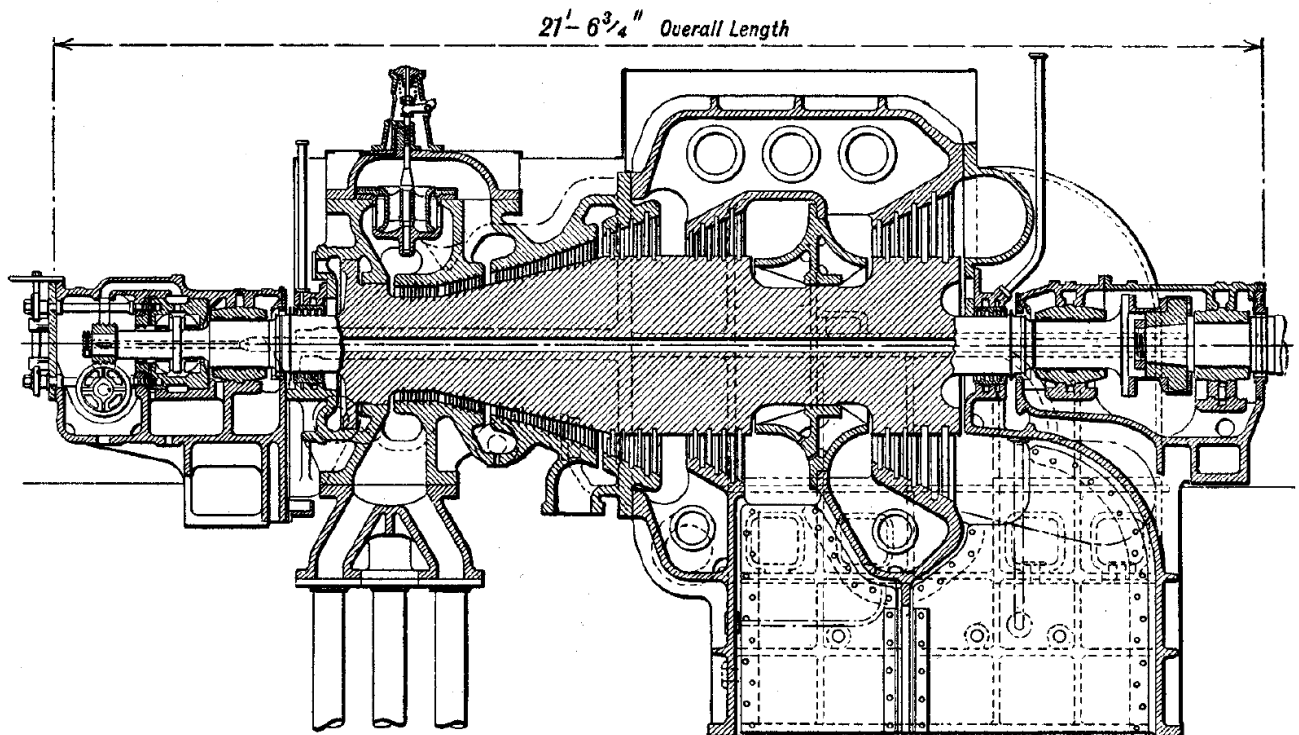

Fig. 66 Cross-section through a 12 MW 3,000 revs/min duplex turbine for Congella [3]

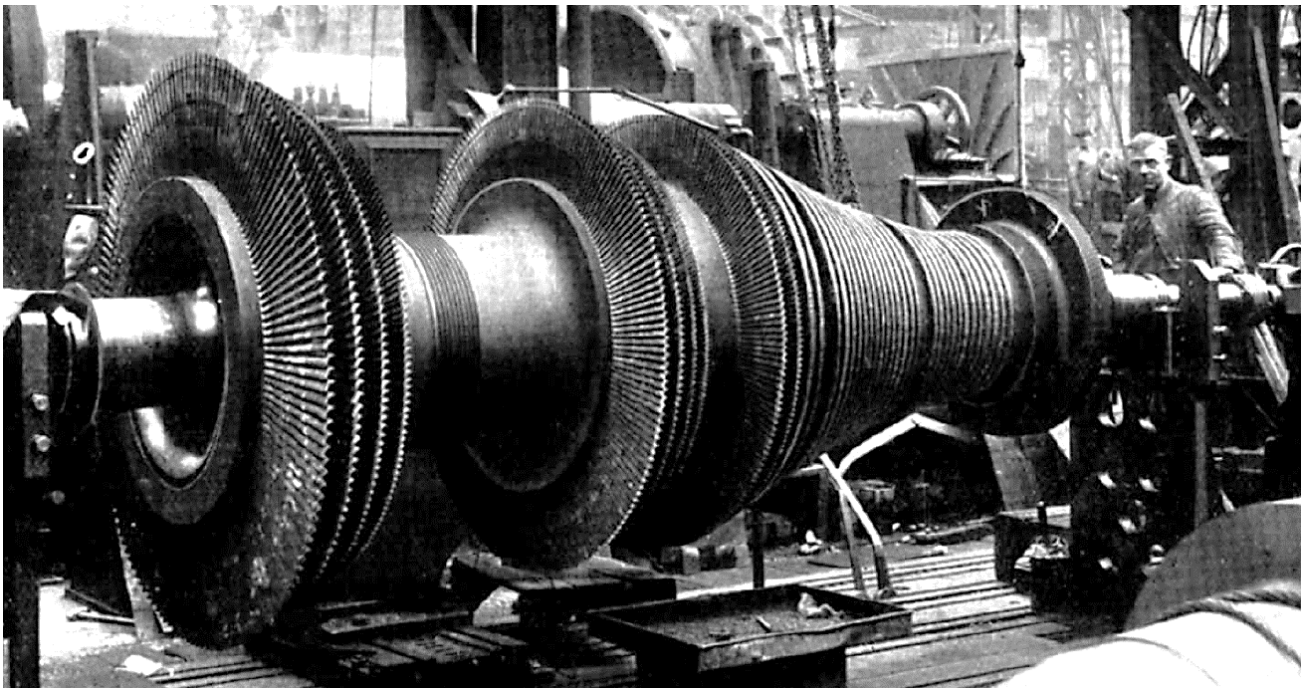

Fig.67 Bladed turbine rotor for Congella [3]

The next step increase in size for duplex turbines occurred in 1928 when a 20 MW 3,000 revs/min unit was designed for Derby PS, fig.68. This was similar to the Congella unit except that four shrunk-on discs were fitted in the second LP flow path. The principle of “adding an exhaust” was applied to two cylinder machines also. In 1926, a 25 MW 3,000 revs/min three exhaust turbine was designed for Brimsdown PS in London, fig.69. This employed last stage blades with a tip diameter of approximately 70” (1.78 m) which was representative of the limit for Parsons full speed blades

at that time. In duplex machines, it became normal to use blades with a tip diameter around 5” (127 mm) smaller in the first LP flow than in the second LP flow (and similarly a smaller first LP flow in three exhaust machines). Figs 68 and 69 show that shrunk disc construction was used in both the Derby and Brimsdown turbines which indicates that as machine size exceeded 20 MW at full speed in the late 1920s, it wasn’t possible yet to obtain single piece forgings for the largest units especially with the heightened awareness of the risks of forging flaws after the Shanghai failure. Nevertheless, forgemaster’s capabilities were also developing at a rapid pace to match the design engineer’s needs.

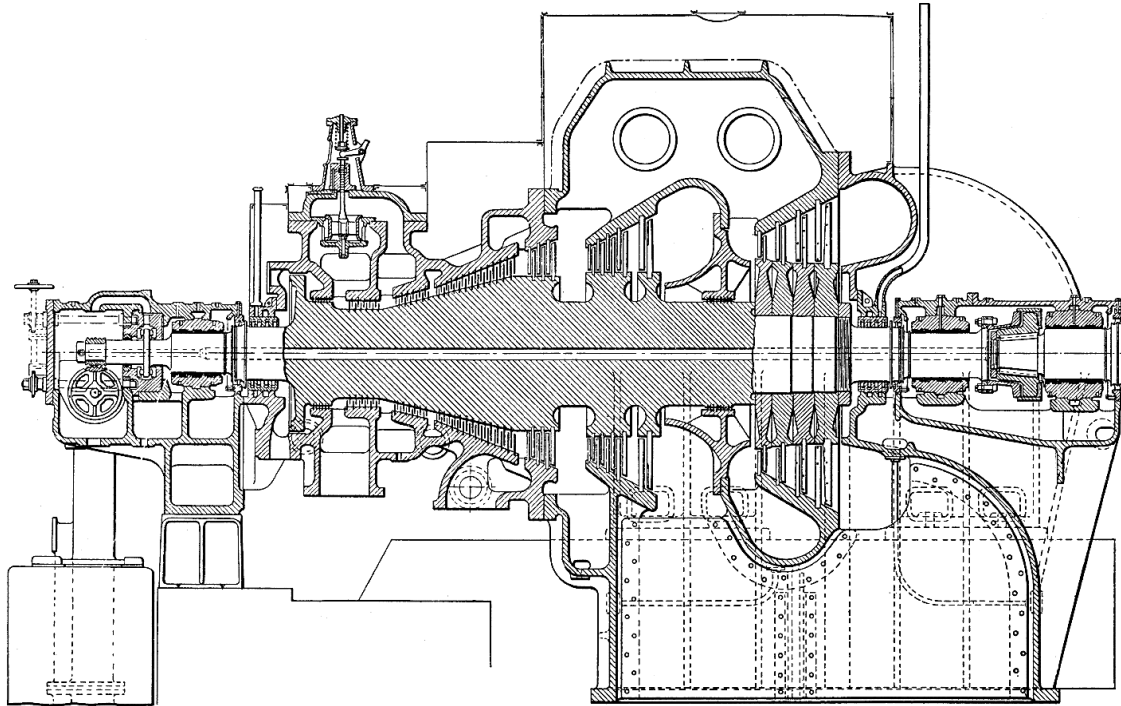

Fig.68 20 MW 3,000 revs/min duplex turbine for Derby 1928 [3]

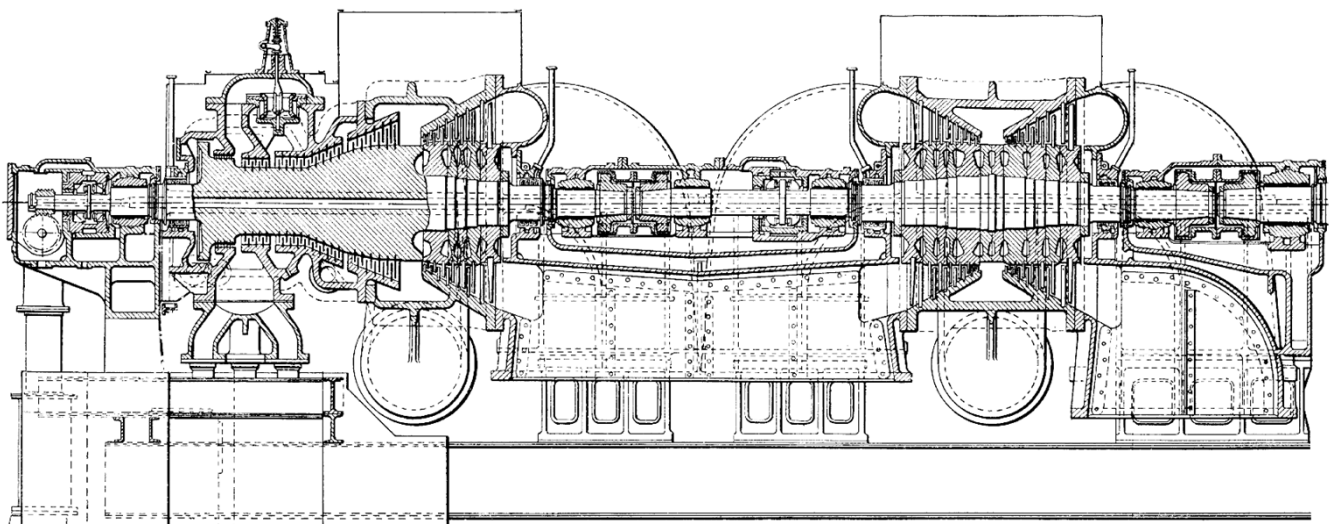

Fig.69 25 MW 3,000 revs/min three exhaust turbine for Brimsdown 1926 [3]

It was also normal practice for the main steam chest to be mounted off the machine and connected to the turbine casing by four loop pipes, following the Barking and Crawford Avenue designs. Fig.70 shows the steam chest of the Brimsdown units with one emergency stop valve (ESV) and one governor valve (GV). Since the steam pressure was only 290 lbs/in² gauge (20 barg) on this set and valve throat velocities were low, the ESV was a simple plate valve and the GV was a hollow

double beat valve (to minimise the valve actuator size). Neither valve had a diffuser. The hollow double beat valve for the bypass inlet was built into the turbine casing, as this was considered to be the safest arrangement ie this valve was arranged in series downstream from the steam chest such that all steam flow would be cut off when the main valves tripped shut.

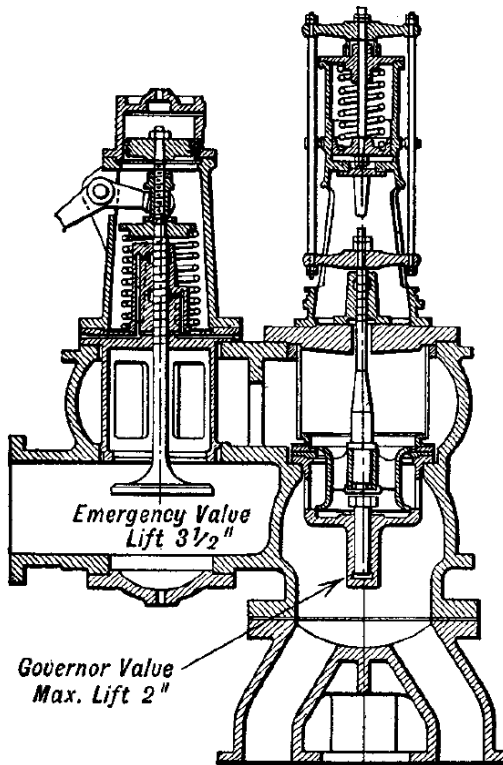

Fig.70 Main steam chest for the Brimsdown 25 MW units [3]

In 1929, turbines of 30 MW output at 1,500 revs/min were manufactured for Ijmuiden PS, Velsen in the Netherlands, fig.71. Inlet conditions were 400 lbs/in² gauge 752°F (27.6 barg 400°C). This design shows how much reliance was placed on disc construction rotors for units of this size running at half speed at this time.

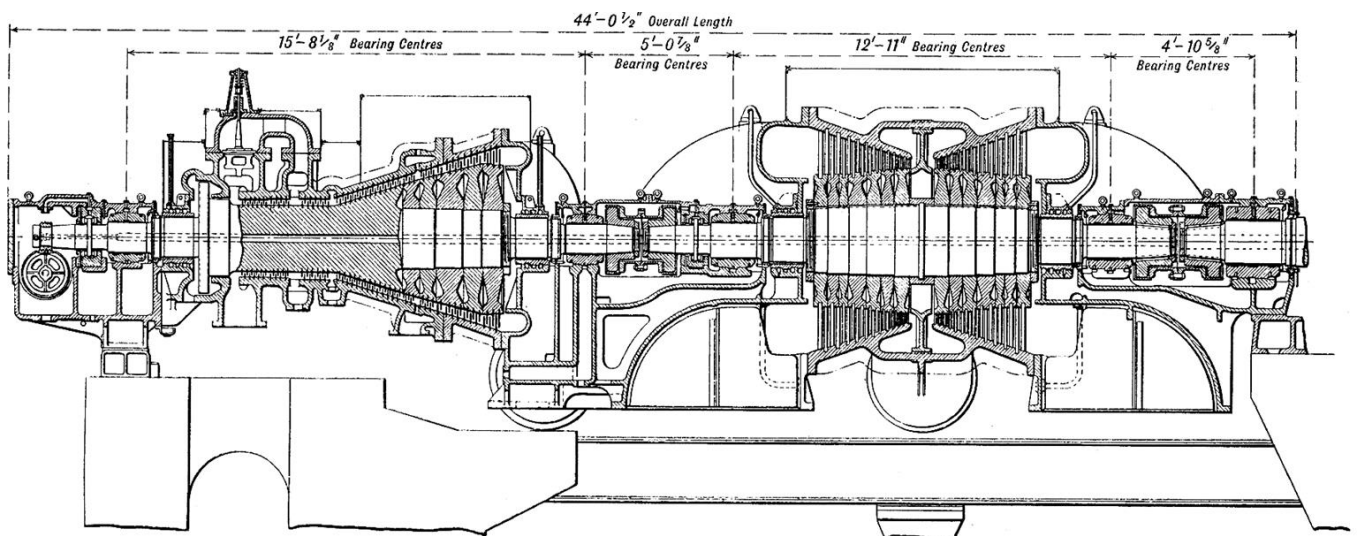

Fig.71 30 MW 1,500 revs/min turbine for Ijmuiden1929 [3]

In 1930, a 30 MW 3,000 revs/min turbine was designed for Hackney in London, figs. 72 & 74. At the higher speed, a monobloc forged rotor could be used in the HP turbine and in the LP turbine only five rotor discs per flow were required. The high speed also reduced the stage count even though an extra blade group was retained at the inlet for bypass governing. Steam conditions were 350 lbs/in² gauge 750°F (24.1 barg 399°C) non-reheat. All steam inlet valves were now mounted off the machine in a dedicated steam chest. The unit had generously sized exhaust hoods – a style which would become known as ‘elephant’s trousers’ in later years. These were also the first Parsons turbines to have tungsten steel erosion shields brazed on to the leading edges of the LP blades and the first to use gland steam condensers.

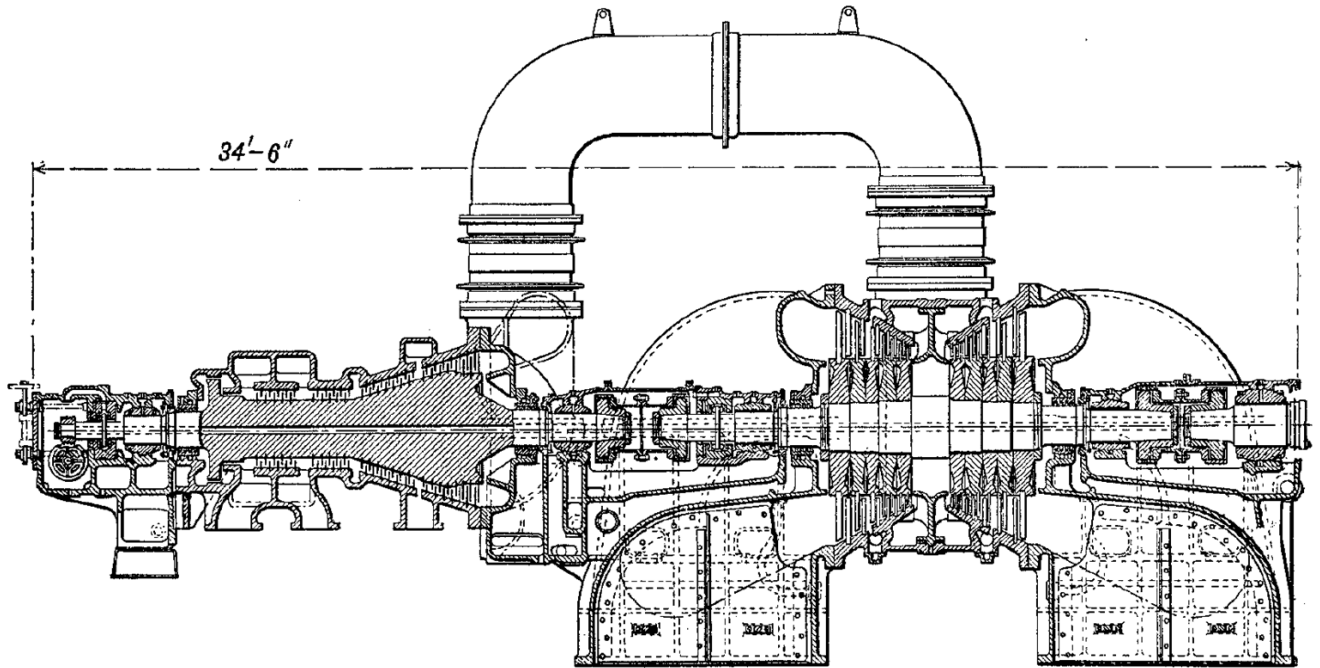

Fig.72 30 MW 3,000 revs/min turbine for Hackney 1930 [3]

End tightened blades were still used in the HP turbine, but with conical blade paths, the design had evolved, fig.73. For example, two fins were used on the fixed blades, one forming a seal and the other helping the tip leakage steam to re-entrain with the main steam flow.

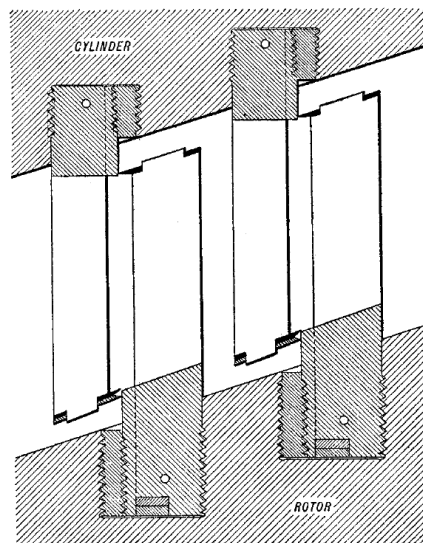

Fig.73 End tightened blading used in the Hackney 30 MW unit [3]

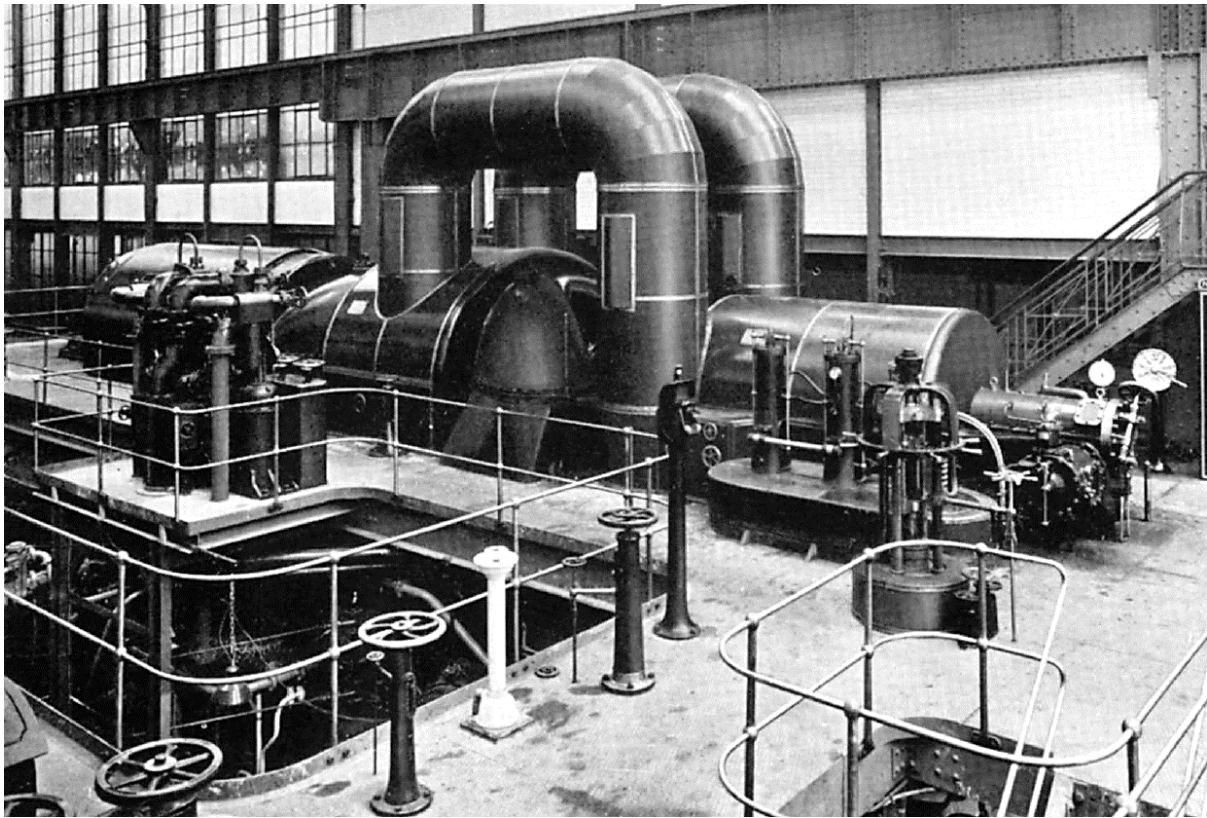

Fig.74 30 MW 3,000 revs/min TG unit at Hackney [3]

In 1930, three 50 MW reheat TG sets were ordered for Dunston B PS in Newcastle. These machines were the last to be designed and built under the direct supervision of Sir Charles Parsons before he passed away in 1931. He decided to use a two cylinder turbine with a single flow exhaust running at 1,500 revs/min, fig.75.

As may be seen, the HP turbine employed hollow and stub construction with three inlet belts for bypass governing. At loads up to 30 MW, steam entered via the inlet adjacent to the dummy piston. For 40 MW, the middle inlet was opened and the first blade group was bypassed. For 50 MW, the inlet furthest downstream was opened to bypass the first two blade groups. The HP turbine inlet conditions were 600 lbs/in² gauge 800°F (41.4 barg 427°C). Reheat conditions were 120 lbs/in² abs 800°F (8.3 bara 427°C). Both the HP and LP turbines used end tightened blades. The units had four stages of feedheating. The heat rate was 9790.4 kJ/kWh corresponding with a cycle efficiency of 36.8%.

The LP turbine rotor used disc construction both for the blade path and the 3 stage dummy piston. The diameter of the exhaust end disc was 78" (1.98 m) and the LP dummy piston was 75.125" (1.91 m). Since Curtis turbines had suffered badly from resonant vibration of the bladed wheels, leading to fracture of the discs in service, Parsons arranged for the discs of all machines to touch each other at the rim to ensure any vibration was damped out. In practice, of course, the discs will have become slightly narrower in width during the run to speed due to Poisson's ratio effects, so small gaps would have developed in service, but the 'touching rims' at least produced a smooth flow boundary, plus oxide would eventually fill the small gaps in service giving the desired contact.

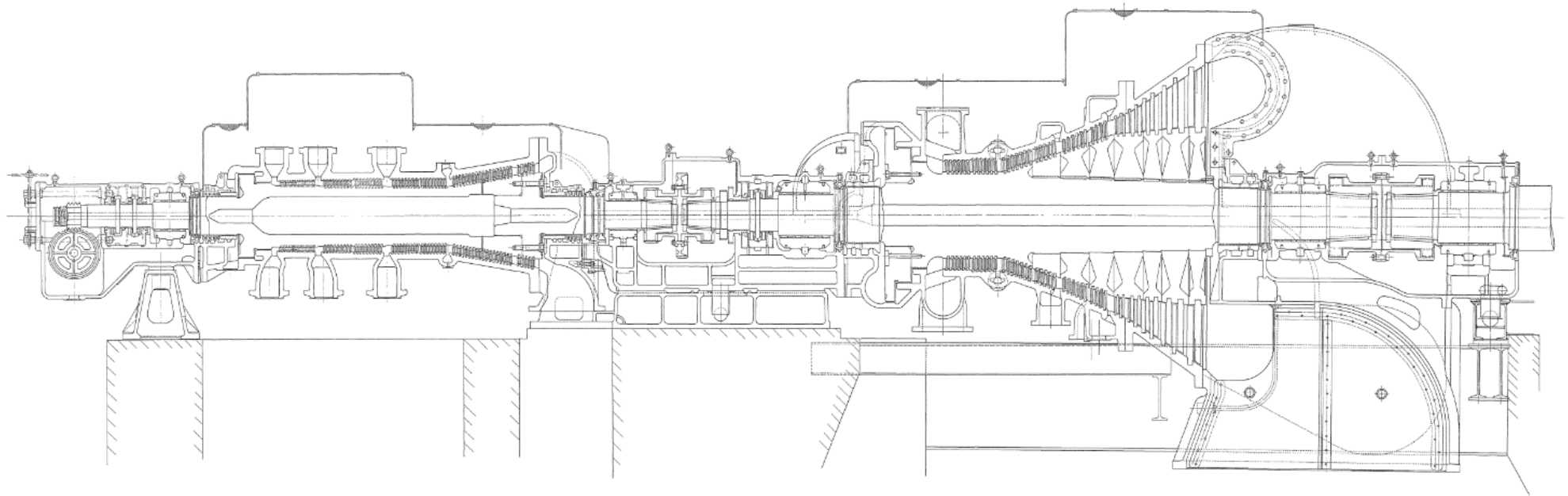

Fig.75 Cross-section through the Dunston B 50 MW 1,500 revs/min turbine 1930 [3]

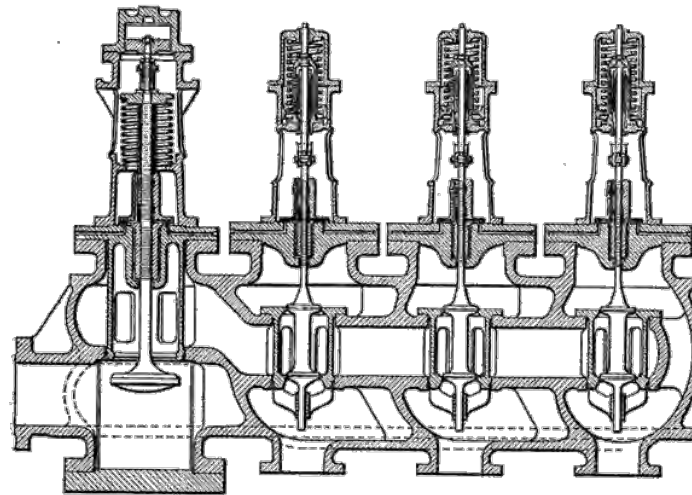

Fig.76 Dunston B steam chest showing one emergency stop valve and three governor valves [3]

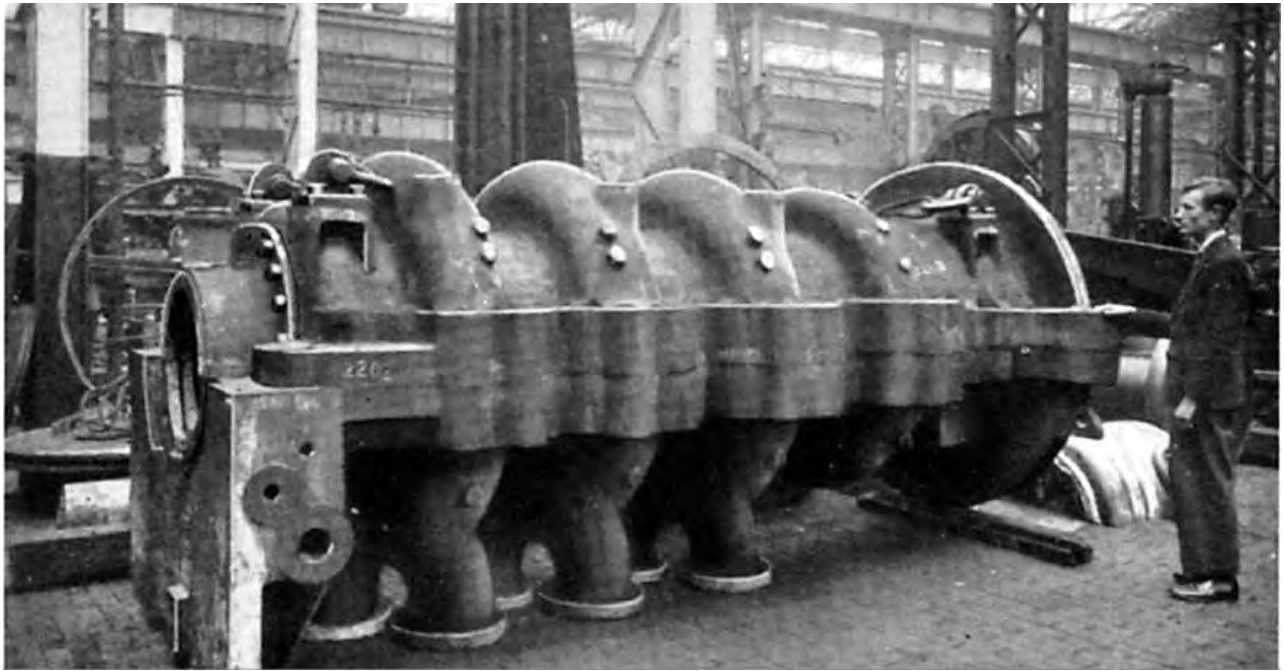

Fig.77 External view of Dunston B HP turbine casing [3]

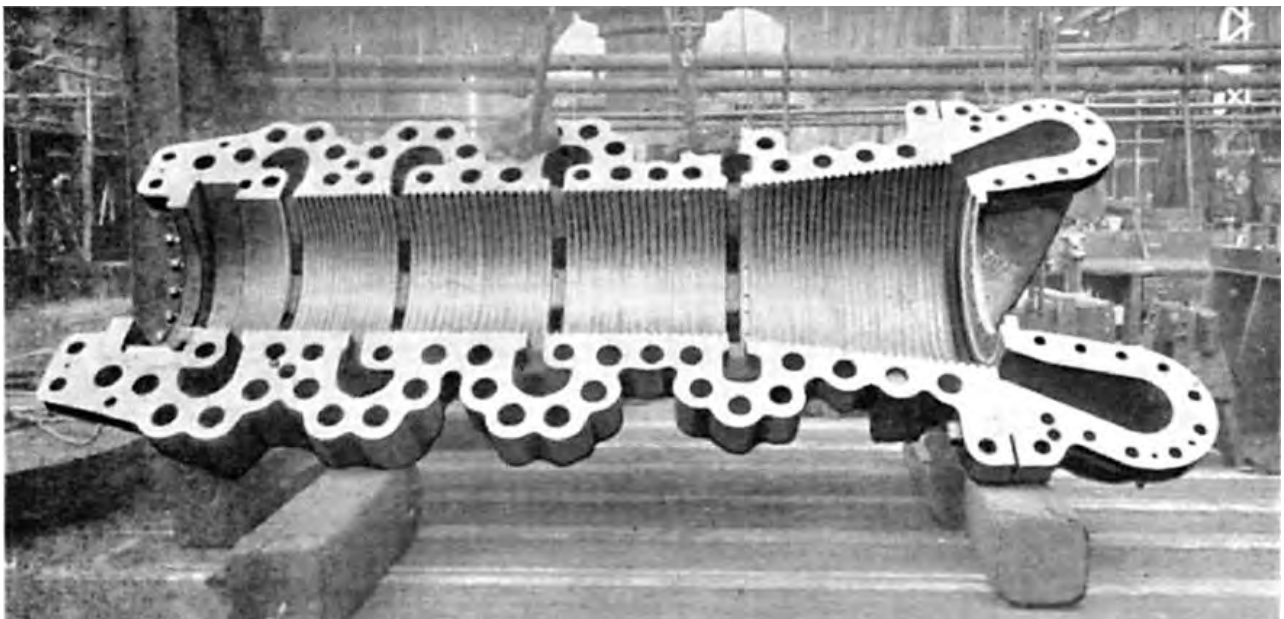

Fig.78 View on the horizontal joint of the Dunston B HP turbine casing [3]. Pillars of metal connected each side of the inlet and extraction belts to limit movements of the bladed sections of the casing in service. Vertical knife cuts were made from the outside of the horizontal joint flange into each bolt hole to avoid the flange adding too much stiffness.

The steam chest, fig.76, retained a plate type emergency stop valve but used solid double beat governor valves. The change from hollow to solid double beat valves had occurred during the late 1920s to reduce the forces on the valves caused by changes in steam momentum which could lead to valve vibration [3]. This simplified the construction of the valves but made the steam chest castings more complex. As years passed by, foundries eventually lost the skills to produce these castings, and as a result, any replacement steam chests in later years had to be based on a different design.

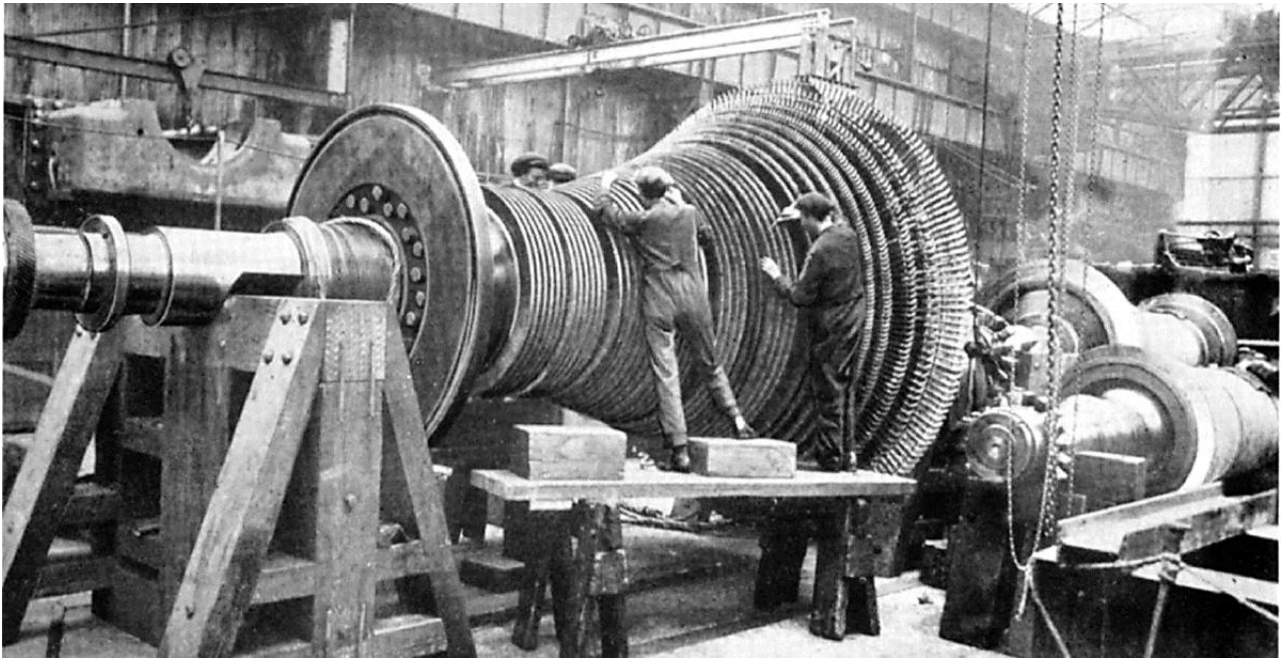

Fig.79 Blades being fitted to a Dunston B LP turbine rotor [3]

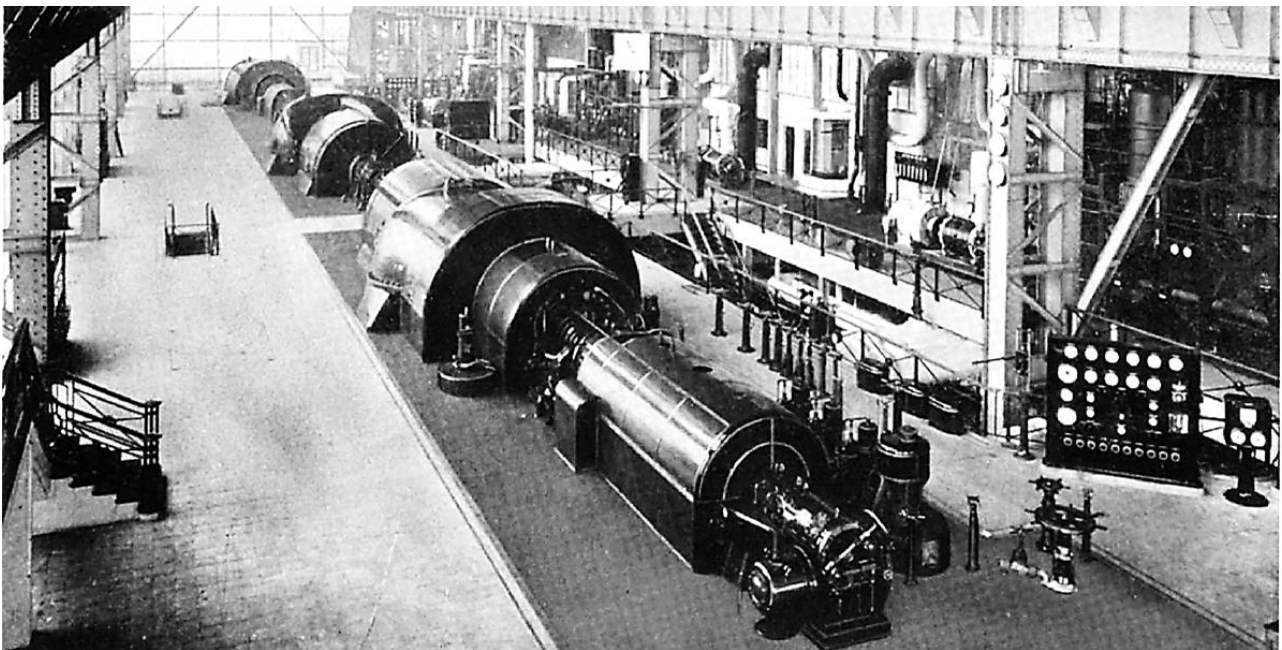

Fig.80 Three 50 MW 1,500 revs/min units in Dunston B [3] A fourth unit was added in the late 1930s. Subsequent units installed in the 1950s were high speed sets.

A major innovation on the Dunston B units was the introduction of hollow LP last stage blades, figs.81 & 82. These were produced by placing a core of mild steel between two layers of stainless iron. This composite structure was then hot rolled to form the aerofoil shape and to fuse the stainless iron plates together. Lacing wire holes were drilled in the blade. Each blade was then placed in boiling 50% nitric acid which dissolved the mild steel core out leaving a hollow aerofoil. By eliminating material, stresses in the blade were reduced allowing greater freedom to shape the aerofoil to better effect. For example, the chord width of the blade at the tip was larger than that allowed with solid blades which improved the blade pitch-to-chord dimensions. All new, large Parsons last stage blades used this construction until 1951, with the manufacture of spare blades

continuing until 1980. It was successful in service, and it helped to earn significant prestige within the industry.



Fig.81 Dunston B last stage blade



Fig.82 Close up view of the Dunston B blade showing the hollow aerofoil and the blunt-faced erosion shield attached to the leading edge, *right hand side*

The Dunston B last stage blade was 25.885" (657.5 mm) long with a tip diameter of 129.77" (3.3 m).

Industry preference for particular turbine sizes and configurations 1930 to 1945

The Great Depression of the 1930s did not suppress turbine orders too much as there was a perpetual need for more electricity. The no. of employees at CA Parsons & Co increased from approximately 1,800 in 1930 to 2,980 in 1939. However, in terms of development, power generation companies started to focus on certain preferred machine sizes and steam conditions restricting the building of larger sets and the use of highly elevated operating conditions to experiments at only a few power stations.

At first, there were three favoured configurations for mainstream orders:

- Half speed machines with a single exhaust like Dunston B for units up to 50 MW.
- Duplex turbines for units operating at moderate pressure and without reheat up to 30 MW.
- Full speed, tandem compound units up to 30 MW.

Dunston B-type half speed turbines

While favoured at first by Sir Charles Parsons, this machine type was installed in only four power stations: Dunston B, Dalmarnock and Hams Hall A & B. The last units to be manufactured were ordered in 1944 for Hams Hall B and were rated at 53.5 MW 1,500 revs/min at steam conditions of 650 lbs/in² gauge 825°F (44.8 barg 441°C).

While the design was quickly superseded, the construction of the LP turbine rotor was employed for large single cylinder turbines up until the 1970s. The challenge with single cylinder machines has always been that the inlet region of the shaft needs to have good high temperature material properties (creep strength, thermal fatigue endurance and thermal ageing resistance) while the exhaust region needs high tensile & fatigue strength at the rim to withstand the forces from the LP blades plus good fracture toughness in the rotor core. With inlet temperatures after 1945 rapidly increasing to 1050°F (565°C), see later, it wasn't possible to provide monobloc forged shafts with the required combination of properties until the 1980s. So, the Dunston B arrangement in which separate discs were mounted on a parent shaft, each part capable of being made from different steels, gave a useful solution.

Duplex turbines

As mentioned above, this design was much lower cost than a two cylinder unit with a separate double flow LP turbine, but it had certain limitations. Firstly, there was no scope to accommodate reheat. This wasn't a major issue in the 1930s as most stations were still non-reheat, but this was going to change. Secondly, high inlet pressures required an increased stage count and the space available for the blade path in the duplex turbine was limited.

Duplex turbines evolved during the 1930s to 20 MW, 25 MW and finally 30 MW at 3,000 revs/min with inlet conditions of typically 250 lbs/in² gauge 700°F (17.2 barg 371°C). The last 50 Hz machine was built in 1937 (30 MW for Congella PS). The design was also used up to 30 MW at 3,600 revs/min (dynamically equivalent to 43.2 MW at 3,000 revs/min) in Canada with steam conditions of 400 lbs/in² gauge 800°F (17.2 barg 427°C). The last 60 Hz machine was a 20 MW TG set manufactured for Saskatoon PS in 1951.

Full speed, tandem compound machines

In the early 1930s, many units in the 10 to 30 MW size were built. In 1937, three 40 MW units at 3,000 revs/min were manufactured for Table Bay PS in South Africa, figs.83 & 84. These machines were required to be capable of running at loads up to 50 MW for 2 hours at a time. Rated inlet conditions were 600 lbs/in² gauge 800°F (41.4 barg 427°C) and there were 4 stages of feedheating.

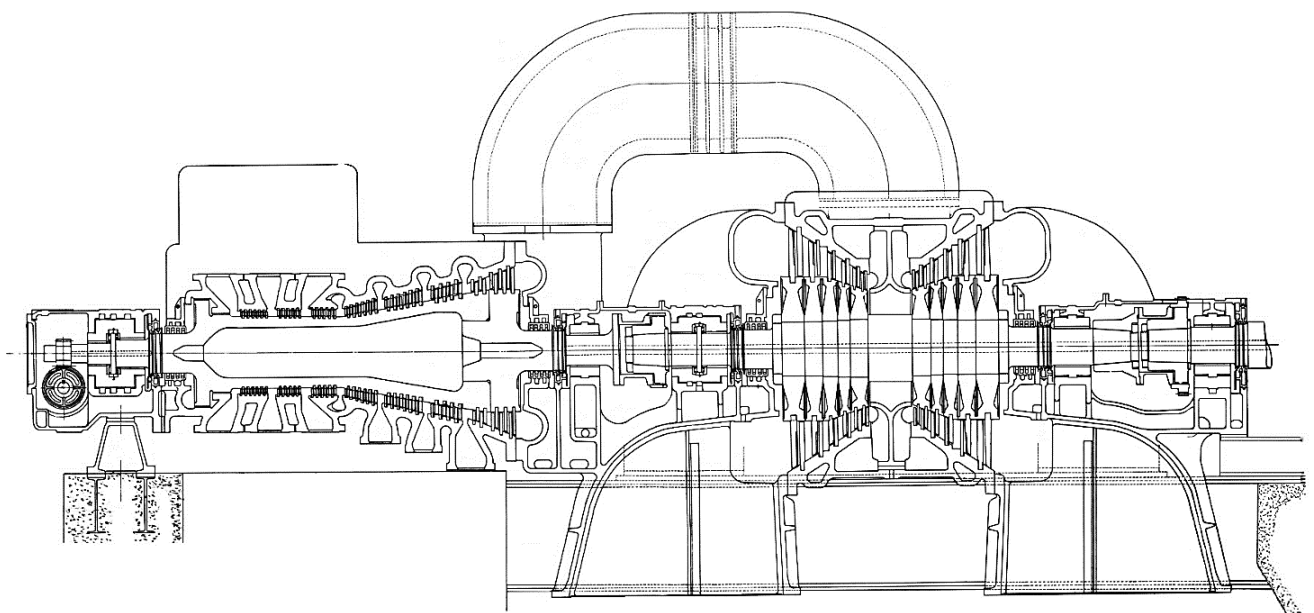

Fig.83 Table Bay 40 MW 3,000 revs/min turbine 1937

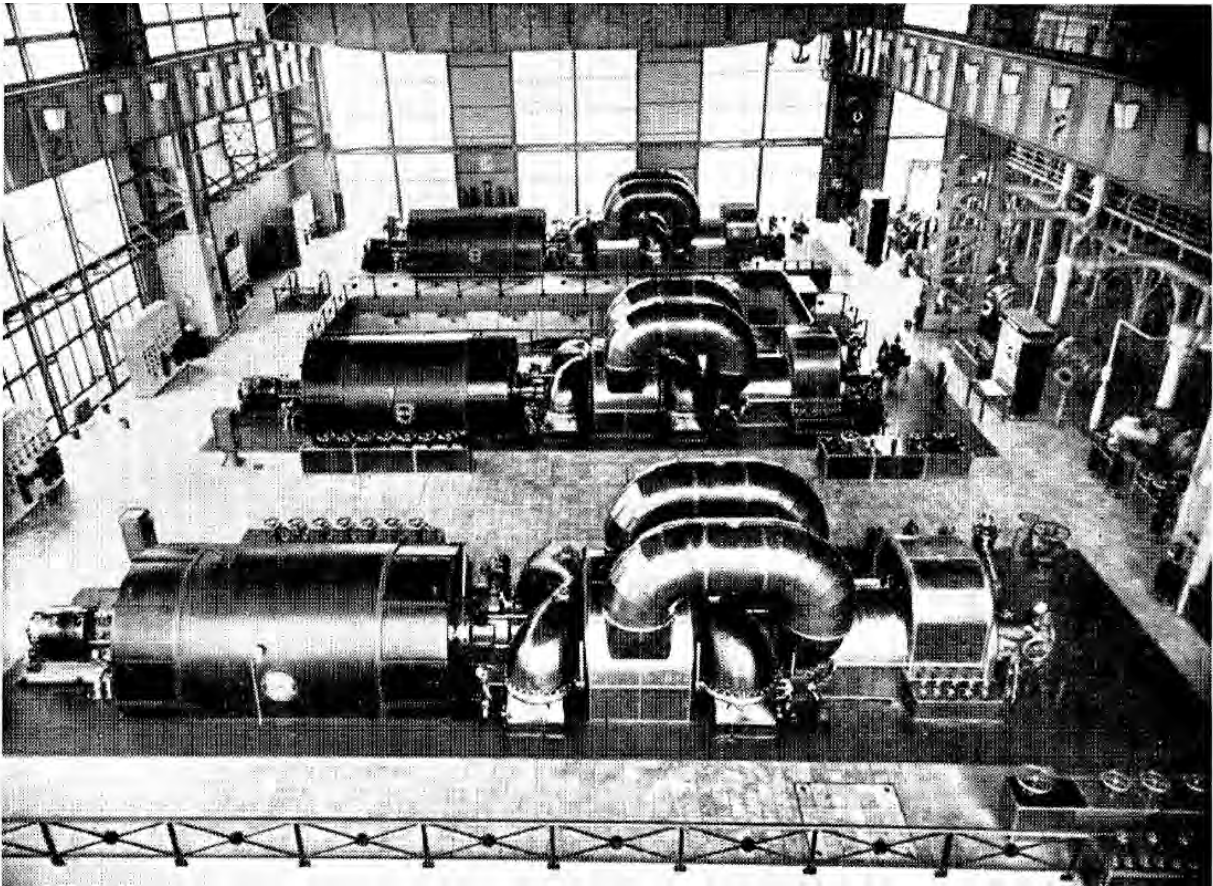

Fig.84 Three 40 MW units installed in Table Bay

One year later in 1938, an order was won for two units for Bunnerong PS in Sydney, Australia which were required to produce 50 MW continuously at 3,000 revs/min. These were three cylinder machines, figs.85 to 90. Steam conditions were similar to Table Bay at 600 lbs/in² gauge 825°F (41.4 barg 441°C).

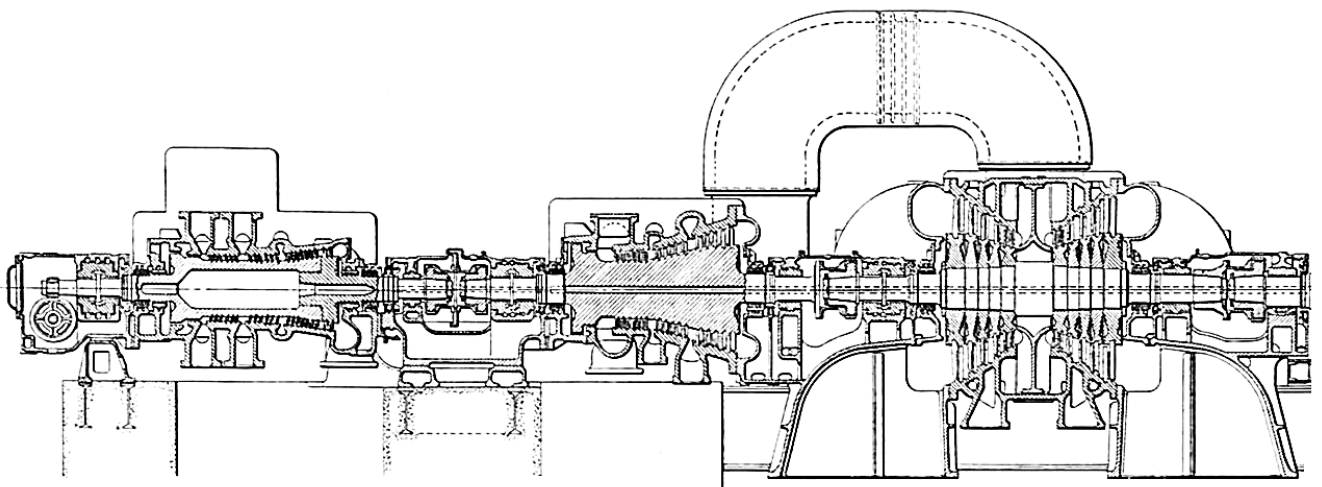

Fig.85 Bunnerong 50 MW 3,000 revs/min turbine 1938

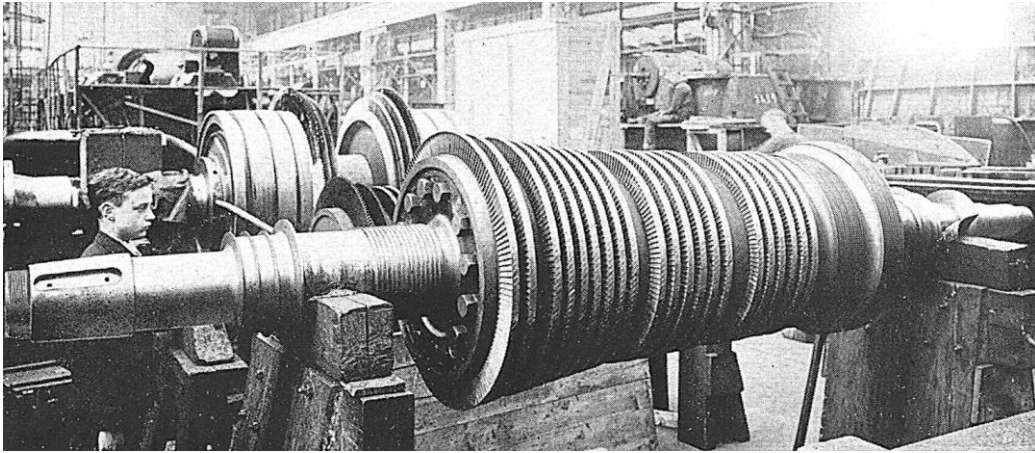

Fig.86 Bunnerong HP turbine rotor

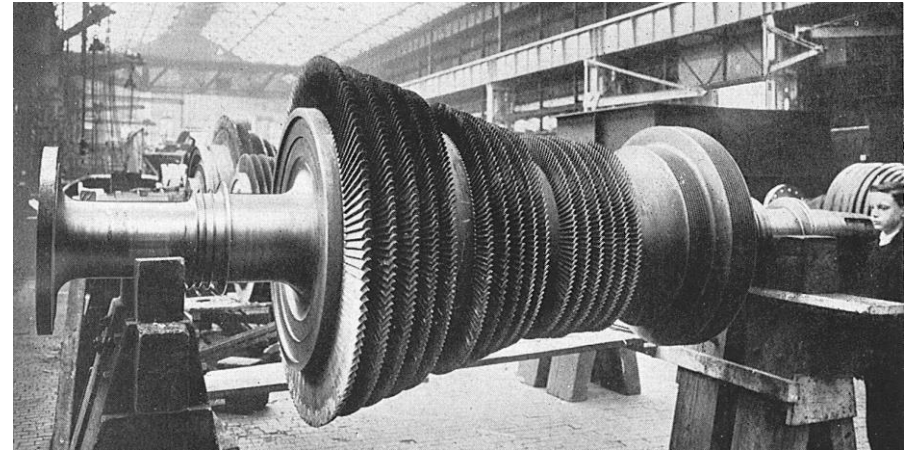

Fig.87 Bunnerong IP turbine rotor

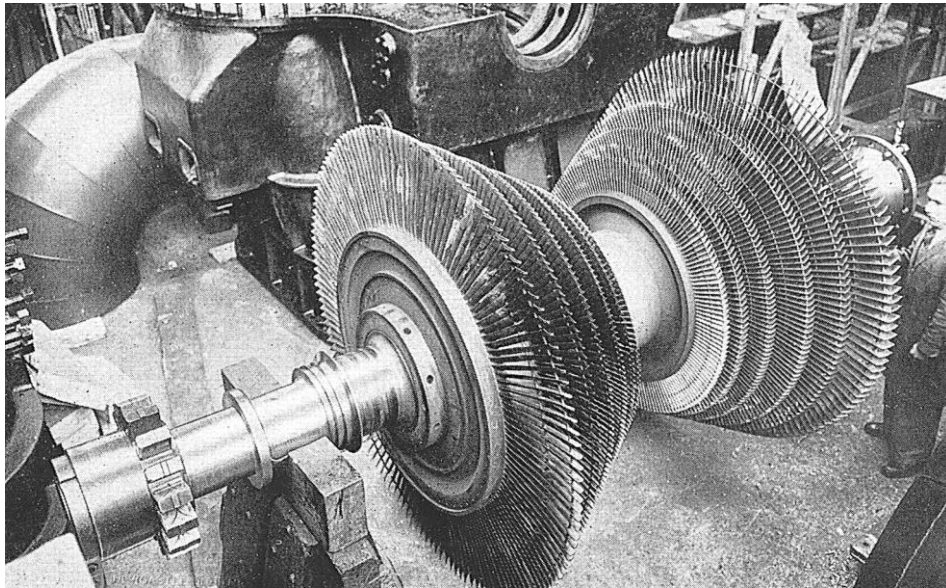

Fig.88 Bunnerong LP turbine rotor

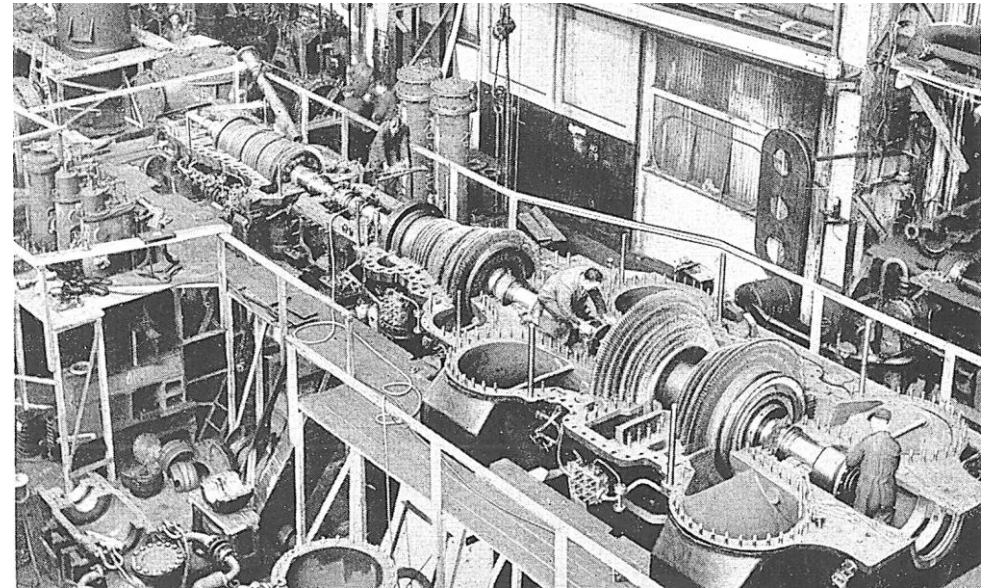

Fig.89 Bunnerong turbine line during assembly

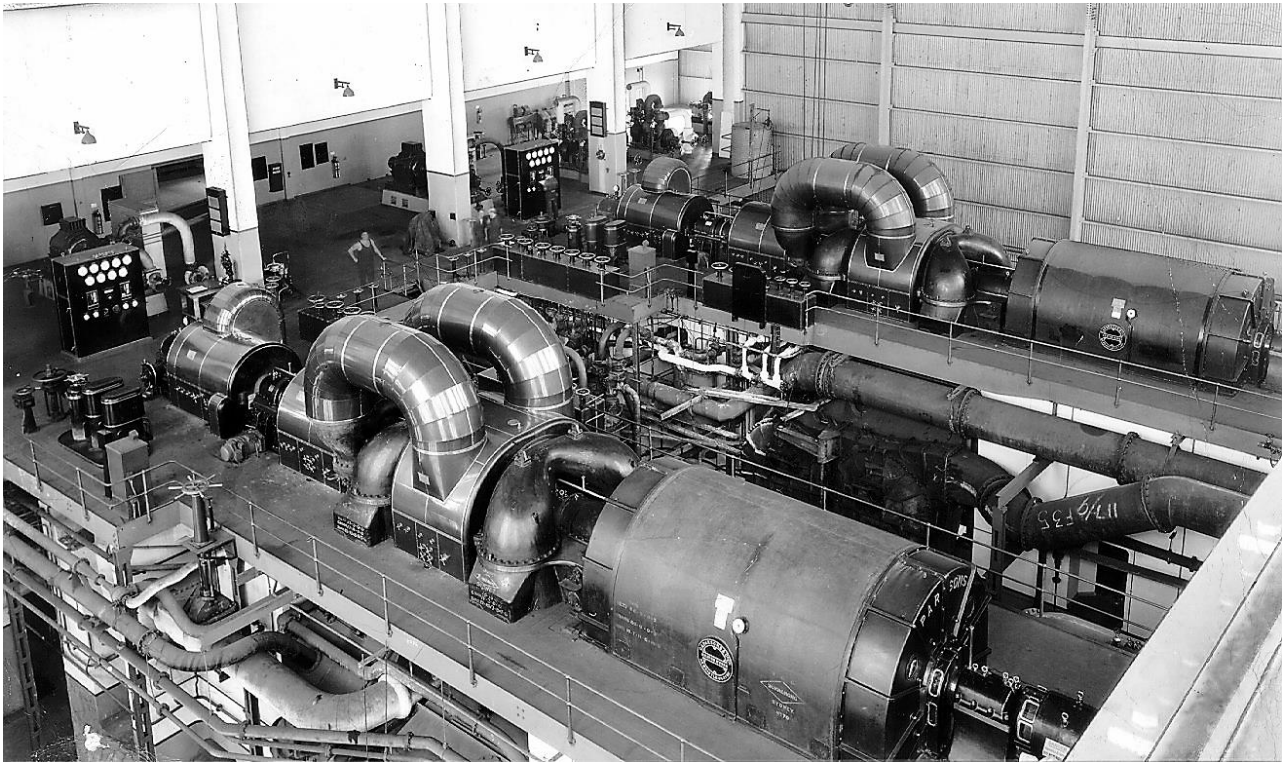

Fig.90 Two Bunnerong 50 MW units installed at site

There are no records to explain why it was decided to adopt a three cylinder arrangement just one year after Table Bay. The two designs had identical stage counts (37 stages in Table Bay HP, 21 stages HP and 16 stages IP in Bunnerong with 6 stages per flow in both LP turbines), both used 80" (2.03 m) tip diameter last stage LP blades with 16" (406 mm) long hollow aerofoils, both had similar shaft diameters, both had 4 stages of feedheating etc. By the 1950s, operating experience showed that Table Bay experienced two issues which Bunnerong did not:

- The end tightened blades extended over a much greater length in the Table Bay HP turbine compared with Bunnerong. The axial seals furthest from the thrust bearing suffered greater than expected wear.
- In the 1930s, people didn't know that end tightening was approaching the limit of its capability in machines of 50 – 60 MW rating. In the 1950s, three cylinder 60 MW sets suffered stiction in the claw coupling of the HP shaft when machines were started quickly. Specifically, during rapid starts, the HP turbine could develop full power before the rotor had expanded fully. With 19.2 MW being transmitted through the HP-to-IP claw coupling of a three cylinder 60 MW turbine at full load, this produced enough friction to affect machine behaviour adversely even with modifications. Table Bay HP coupling passed 37.2 MW at full load, whereas Bunnerong passed 17.2 MW, so Table Bay was much more susceptible to this.

While these issues would emerge later, the first Table Bay unit wasn't in service when Bunnerong was designed so these points were not yet known. It can only be assumed that the reason for the change to three cylinders occurred due to the judgement of a new Chief Design Engineer, operating experience on smaller units, manufacturing considerations or something similar.

A key change which occurred in 1933 was the introduction of the 600 series aerofoil for reaction blades, fig. 91. Development of this blade had started in 1926. It achieved a peak stage efficiency of 93%, 3 percentage points more than the 400 series blade. It was efficient but it was a slender profile with little camber. It was perfectly satisfactory for the 30 & 50 MW sets of the 1930s, but it needed to be reinforced when it was used for turbines of 200 to 660 MW rating at 3,000 revs/min

in the 1960s. In the coming years, considerable work would be undertaken to identify a more efficient blade with higher bending strength, but the 600 series design wasn't superseded by a better blade until 1985 and the introduction of the R series profile, see later.

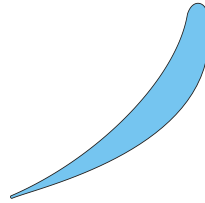

Fig.91 The 600 series aerofoil

In terms of highest temperature, Lots Road adopted an inlet temperature of 900°F (482°C) for new machines in 1931 but this was not yet an industry standard. In terms of highest pressure, stop valve conditions of 800 lbs/in² gauge 800°F (55.2 barg 427°C) were employed on turbines of 5 and 20 MW at 3,600 revs/min supplied to the Ford Motor Co of Canada in 1935 & 36, see figs 92 & 93.

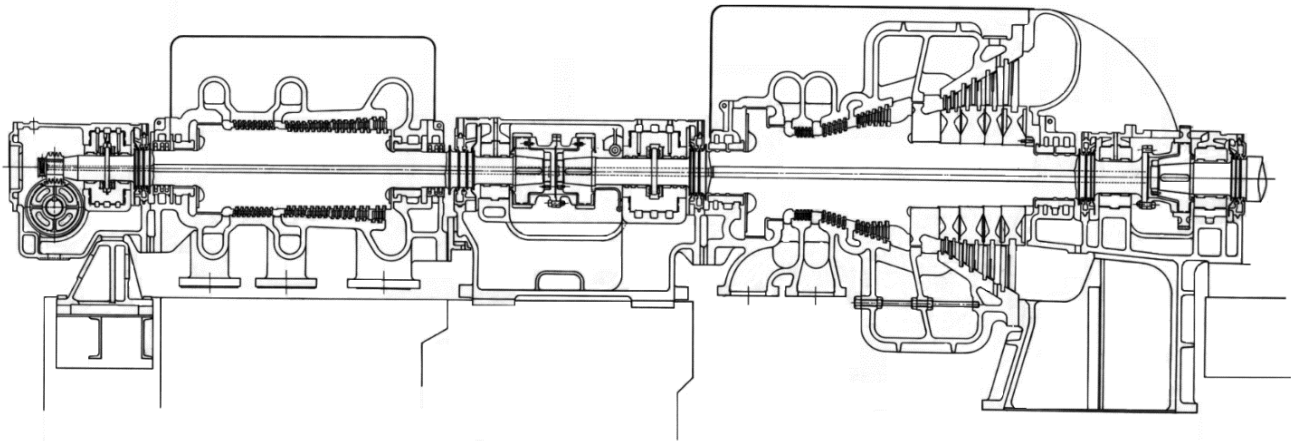

Fig.92 Cross-section through the 20 MW 3,600 revs/min turbine for the Ford Motor Co of Canada 1936. The dividing wall with valves (not shown) controlling the flow of steam into the LP blading allowed the unit to supply process steam at a controlled pressure.

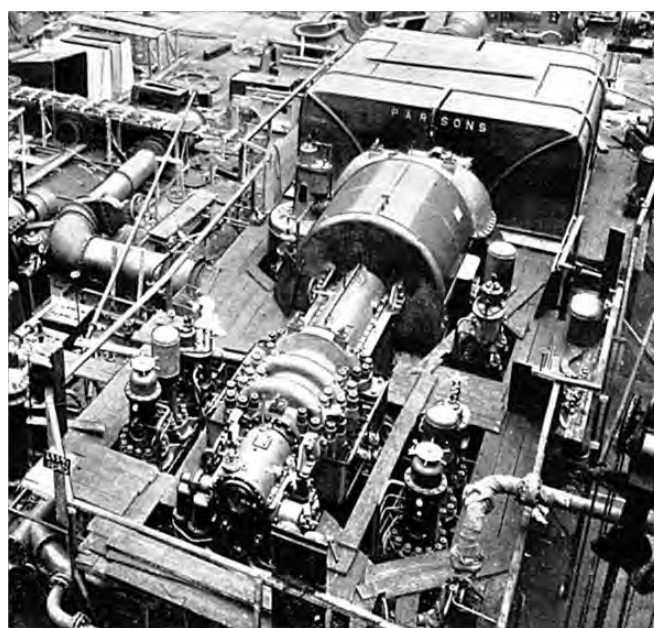

Fig.93 The Ford Motor Co 20 MW set during testing at Heaton Works

During the Second World War, orders were placed for conventional designs in the UK and overseas without developing higher power outputs or using higher steam conditions. The most unusual machines were manufactured between 1942 and 1945 for supply to the USSR. Several machines were designed which were out of the ordinary. Figs 94 & 95 show two of these which had large steam extractions for district heating or process use. Since there was no possibility of sending Parsons staff to Russia during the war years, the operating manuals had extensive instructions on every aspect of their use from installation and commissioning to subsequent operation. Drawings were supplied in Russian language. No one at Heaton Works knew where the units were installed as the code names 'USSR power stations 2A, 6A, 17A and 19A' were used to disguise their locations. In the current history work, efforts are being made to try to find out where they were sent, but so far without success.

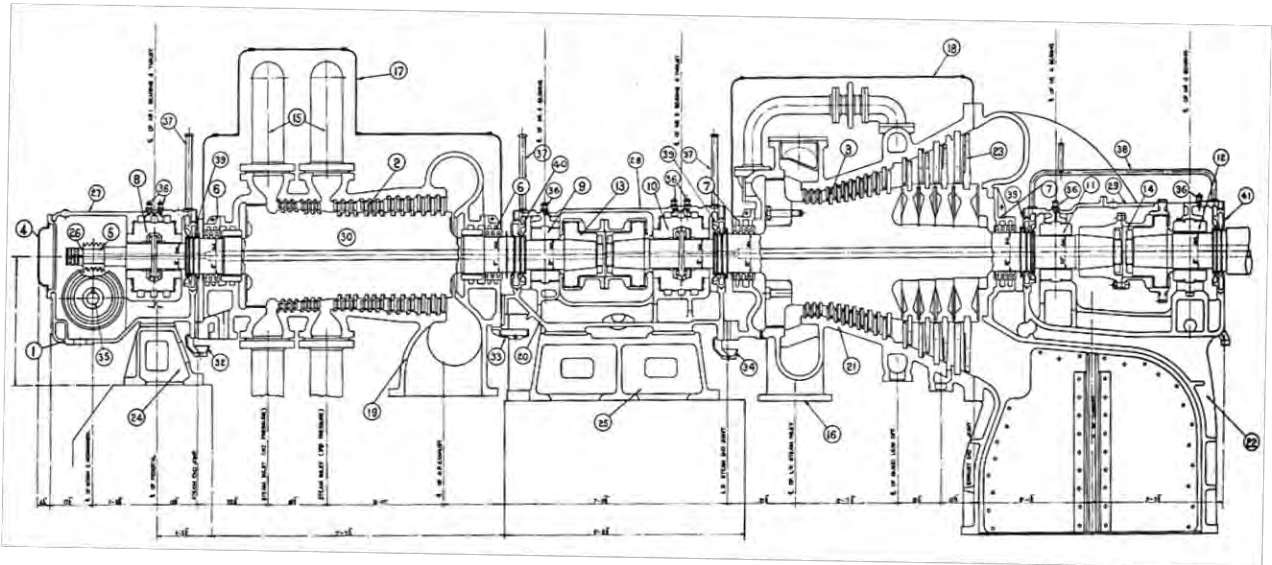

Fig.94 25 MW 3,000 revs/min unit supplied to USSR power station no.19A. Stop valve conditions were 27.5 barg 400°C. The unit was bypass governed with a large extraction for district heating or process steam from the HP turbine exhaust.

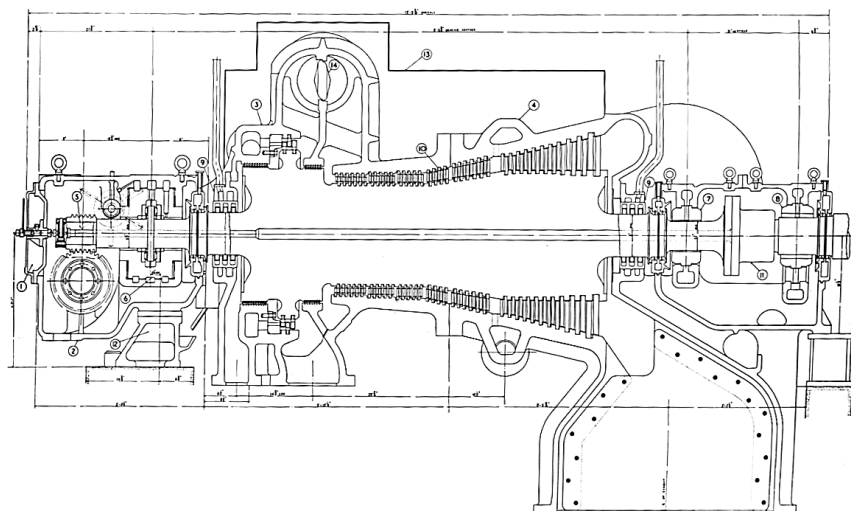

Fig.95 2.5 MW 3,000 revs/min turbine. Five units of this type were supplied to the USSR during World War II for unknown destinations. Stop valve conditions were 27.5 barg 400°C. The units were nozzle governed with an extraction immediately after the Curtis stage at a controlled pressure for district heating or process use. Since the Curtis stage nozzles were choked at all loads, the mass flow rate passing through the inlet stage was unaffected by the fixed extraction pressure, but the Curtis stage outlet temperature will have changed markedly as the electrical load was varied.

The influence of Sir Claude Gibb: the third era of rapid growth in company size, machine size and the development of nuclear power 1945 to 1965

Sir Claude Gibb



Fig.96 Sir Claude Gibb in 1945

As mentioned previously, Claude Gibb had impressed Sir Charles Parsons in the 1920s and had been granted the opportunity of becoming Technical Director of CA Parsons & Co. In the 1940s and 50s, he was to have a dramatic effect on the company. First, though, he was called upon to support the war effort.

In 1940, Engineer Vice-Admiral Sir Harold Brown, who had been Engineer-in-Chief of the Royal Navy, was appointed Director-General of Munitions Production at the British Ministry of Supply. Following the fall of France, Sir Harold decided to recruit additional people as part of his team. He had met Claude Gibb and had been impressed by him in the 1930s, so Claude was asked to join his staff. He soon earned a reputation for his “irresistible driving force” and tireless energy. Initially, Claude was Engineering Assistant and then Deputy to Sir Harold. In 1941, he became Director-General of Weapons and Instrument Production. In 1943, he became Director-General Armoured Fighting Vehicles, and in 1944, Chairman of the Tank Board. Under his leadership, the Sherman tank was modified to take a 17 pounder gun and work started on developing the Centurion tank, for example. In recognition of his service, he was awarded a CBE in 1942 and a knighthood in 1945. During this time, Sir Claude retained his position on the Parsons board, and in 1944 was appointed joint Managing Director with Mr FGH Bedford. He was invited to become Chairman of Parsons when Mr Bedford retired. This occurred in September 1945 and Sir Claude then became Chairman and Managing Director.

While at the Ministry of Supply, Sir Claude could see that there would be a massive demand for turbine-generators after the war both to replace war damaged plant and because there would be high growth in the demand for electricity. He instructed that Heaton Works should increase in capacity three fold and the no. of employees should increase from 2,980 in 1939 to approximately 10,000 by 1960. He also knew that turbine-generator sizes would have to increase massively. Consequently, he ordered new heavy machine tools, increased the physical size of TG sets the factory could build and started changing buildings and equipment across the whole of CA Parsons. He was responsible for creating the company which most people today remember as the ‘modern Parsons’ ie the company as it existed from 1960 until 2005, with around 70% of the buildings at

Heaton, Walkergate and Longbenton Works being constructed new from 1947 onwards as a result of his influence.

Further to this, he could see that nuclear power would become a key part of power generation. Consequently, he initiated discussions with the Ministry of Supply and the Atomic Energy Research Establishment in 1946 which led to Parsons becoming heavily involved in the nuclear industry manufacturing large magnets for cyclotrons and other nuclear research equipment initially, then winning the order to design and manufacture most of the steam plant for Calder Hall, the World's first commercial nuclear power station. He established the Nuclear Power Plant Co – a consortium of 8 companies including Parsons – to build further nuclear stations. The NPPC subsequently merged with AEI-John Thompson around 1960 to form The Nuclear Power Group and later would become part of the National Nuclear Corporation. He also developed daughter companies eg the Anglo Great Lakes Corporation which was established in Newcastle in 1957 and was one of only two companies in the UK which could supply nuclear graphite for reactor cores.

He also built new Research and Development facilities to advance the technology of both conventional and nuclear plant. In 12 years, between 1946 and 1958, Parsons TG sizes increased from 50 MW to 550 MW at 3,000 revs/min and steam conditions increased to 2,350 lbs/in² gauge 1050°F (162 barg 566°C) by 1956.

In addition, CA Parsons & Co developed the UK's first industrial gas turbine which began operation in 1945. Sir Claude then ensured that new Gas Turbine and Compressor Depts were established including manufacturing facilities at Heaton and Longbenton Works.

UK Industry changes

Within the industry, large changes were also taking place.

In 1945, the capacity of the UK national grid was 12.9 GW. There were 569 separate electricity companies involved in producing and distributing the power. The existing 132 kV grid had been developed primarily to link power stations and distribution systems located around towns and cities. Even with a grid, ~60% of electricity was supplied to customers directly from the generator busbars. The capacity of the system needed to increase substantially to meet demand, the size of machines and the technologies used had to escalate, a second grid capable of transmitting much greater power over larger distances and with spare capacity for future growth had to be built, the decisions on what should be constructed needed to be coordinated and the system had to be run efficiently.

In 1948, the UK Government decided to nationalise the companies involved in the generation, transmission and distribution of electricity. The British Electricity Authority (BEA) was formed which included all of the companies in England, Wales and Southern Scotland. Initially, the BEA comprised 14 generating divisions with a total of 297 power stations. It was decided that new power stations would be more economical if they were much larger and located close to the sources of fuel rather than the end users. The construction of a new 275 kV super-grid started in 1953. Sections would be upgraded later to a 400 kV super-grid starting in 1966.

Following the Electricity Reorganisation (Scotland) Act 1954, the South of Scotland Electricity Board (SSEB) became a separate organisation and the BEA was renamed the Central Electricity Authority (CEA) in 1955. In 1957, a further reorganisation took place. In place of the CEA, the Electricity Council was formed with responsibility for financing, research and industrial relations

while the Central Electricity Generating Board (CEGB) looked after the design, operation & maintenance of the power stations & transmission systems. In 1958, the CEGB comprised 5 generating regions with 2 separate divisions to manage the design & construction of new plant and to carry out research work. [9]

Most of the electricity in the 1940s and 50s was generated using British coal. With a massive growth in demand, the coal industry was under pressure to keep pace and prices soared. This led to a decision to start using oil fired plant in the UK in the 1950s to ease the pressure. Further, when nuclear power was considered to be feasible and economic, this was also pursued.

In the late 1940s, there were severe power shortages in the UK. Consequently, there was an immediate construction program using proven technology (eg 30 - 50 MW sets) together with machines which were only a moderate extension of existing technology (eg 60 MW units at higher steam conditions). The first priority was to build plant quickly 'to keep the lights on'. The second priority was the development of larger, more efficient stations to reduce the cost of power. In 1947, a statutory order was issued which required new turbine-generators to be either 30 MW sets operating with pre-war steam conditions of 600 lbs/in² gauge 850°F (41.4 barg 454°C) or 60 MW units at 900 lbs/in² gauge 900°F (62.1 barg 482°C).

At that time, there were 7 significant manufacturers in the UK market: Parsons, GEC, English Electric, Metropolitan Vickers, British Thomson Houston, Richardson Westgarth and Brown Boveri. The order books for 5 of these companies are available and show that the no. of machines built in the UK after 1945 included:

Parsons: 21 x 30 MW non-reheat 3,000 revs/min units
2 x 50 MW non-reheat 1,500 revs/min units - the last of the Hams Hall units
10 x 50 MW non-reheat 3,000 revs/min units
2 x 50 MW reheat 3,000 revs/min units - prototype sets at Dunston B
41 x 60 MW non-reheat 3,000 revs/min units

GEC: 14 x 30 MW non-reheat 3,000 revs/min units
26 x 60 MW non-reheat 3,000 revs/min units

English Electric: 31 units sized 30 or 33 MW
32 units sized 40, 45, 50 or 60 MW

Metropolitan Vickers: 23 units sized 30 or 31.5 MW
27 units sized 45, 50, 51.5 or 52.5 MW
33 units sized 60 MW

British Thomson Houston: 15 units sized 30 MW
17 units sized 52.5, 53 or 60 MW
3 units sized 75 MW

With units running at 1,500 or 3,000 revs/min, different steam conditions ranging from 400 lbs/in² gauge 800°F to 1,500 lbs/in² gauge 1050°F non-reheat and up to 1,235 lbs/in² gauge 850°F with reheat, with & without bypass governing etc, there was great variety within the CEGB fleet rather than standardisation. So much for the 1947 statutory order!

Let's look at the principal machine types Parsons built:

50 and 60 MW 3,000 revs/min turbines

Parsons first 60 MW units were manufactured in 1946 for North Tees C PS in Billingham on Teesside followed by orders for identical units for Skelton Grange PS in Leeds. These were ordered two years before the formation of the BEA and so were not rated at standard conditions. The stop valve conditions were 900 lbs/in² gauge 925°F (62.1 barg 496°C) and the turbines were bypass governed with 5 stages of feedheating, figs 97 & 98. Reheat wasn't used even though earlier North Tees sets had employed this. At these steam conditions, the steam chemistry had to be better than previous plant and so North Tees C became the first UK power station to use a demineralisation system with cation and anion exchange beds followed by a silica removal bed.

In the 1920s, design engineers had been concerned that steam pressures higher than 650 lbs/in² at 700 – 800°F without reheat could cause excessive erosion due to high wetness at the exhaust. In the 60 MW units, the stop valve temperature of 900°F allowed the steam pressure to increase to 900 lbs/in² while still maintaining the exhaust wetness level at a reasonable value 10.4%. The temperature required new materials around the inlet, and so carbon 0.5% molybdenum steel was introduced for the HP turbine rotor, casings and inlet pipes. This was a fairly crude material by modern standards since manufacturers specified only the required tensile properties plus 'at least 0.5% molybdenum' leaving the remainder to the forgemaster or foundry's discretion. Nevertheless, it proved to be successful with many units completing service lives of over 250,000 running hours and 6,000 starts (the original design life was 15 years or 100,000 hours). When graphitisation caused pipe bursts in the USA, the UK machines were monitored closely but this mechanism didn't affect Parsons plant. This was attributed to the use of less aluminium for deoxidation during steelmaking and lower steam temperatures than American machines.

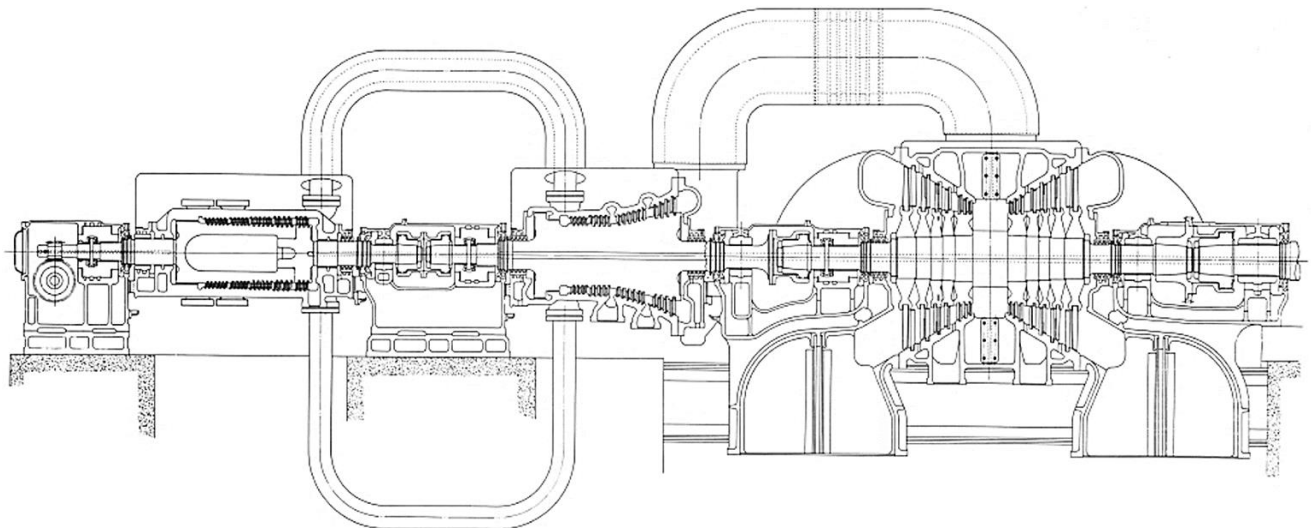

Fig.97 North Tees C & Skelton Grange A 60 MW 3,000 revs/min turbine 1946

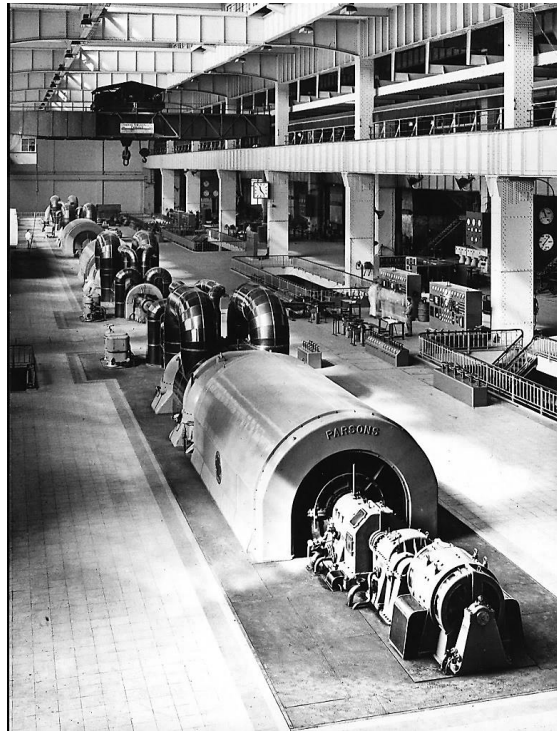

Fig.98 North Tees C turbine hall in 1953

All blades were made from 12 Cr steel. The last stage blades were 18.427" (468.0 mm) long with a tip diameter of 85" (2.16 m). This exhaust size had been adopted on 50 MW units at Braehead PS in Glasgow and achieved leaving losses equivalent to 1.9% of rated power. At 60 MW, with two exhaust flows, the leaving losses would increase to 2.9% which Parsons thought was too high. It was therefore proposed that three exhausts should be used. The customer declined this and chose to proceed with two LP flows. The blades were hollow, similar to the Dunston B blades but running at full speed and with improved aerodynamic erosion shields, fig.99.



Fig.99 Hollow last stage blades used at North Tees C and Skelton Grange A

Parsons proceeded to develop larger blades 20" (508.9 mm) long with a tip diameter of 90" (2.29 m) in 1951 and 22" (558.8 mm) long with a tip diameter of 95" (2.41 m) in 1953. Both of these blades were part of a new generation of designs. They were the first to be mounted using an axial fir tree root fixing, figs.100a and b, rather than being installed in a circumferentially serrated groove.

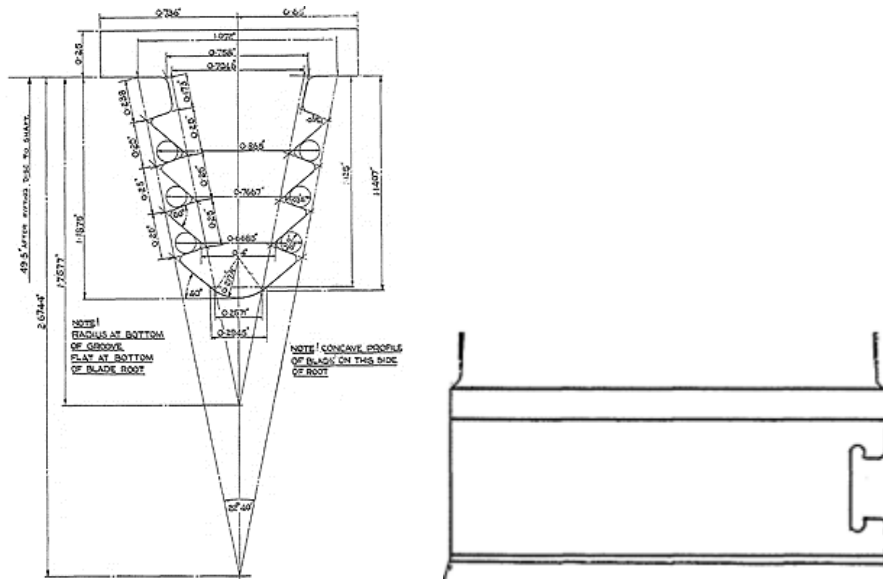

Fig.100a Parsons first axial fir tree root fixing 1951, *left*, and fig.100b side view showing the C-shaped locking groove, *right*

The basic design of the fir tree root came from Sir Frank Whittle's company Power Jets, which had collaborated with Parsons in the development of a 1,000 hp (746 kW) gas turbine to drive a tank. A scaled up version was used next in a 2,500 kW experimental gas turbine installed at Heaton Works. Larger fir tree root fixings were then applied to the 90" and 95" tip diameter steam turbine blades. Even larger versions of the root fixing, with geometry improvements, would be used for blades up to 36" (914 mm) long with a tip diameter of 136" (3.45 m) in 500 & 660 MW 3,000 revs/min units. In the larger blade sizes, the C groove was found to be a stress raiser which needed to be removed, but it was satisfactory on the smaller 60 MW blades.

From July 1951 onwards, it was decided that all new last stage LP blades should be solid rather than hollow due to cost and the difficulty of providing holes for acid to enter and remove a mild steel core when the fir tree root was present. The manufacture of hollow blades for spares continued until 1980 though.

The three cylinder design was chosen because Parsons wanted to use reaction blading throughout with end tightened blades in all of the HP turbine stages and the higher stop valve pressure combined with smaller shaft diameters (needed to maintain satisfactory blade heights with high density steam) required an increased stage count.

The first 14 stages of the HP turbine blade path were made in IFR (integral formed root) construction where each individual blade was machined from a single piece of forged bar with an integral root block and shroud and then the blades were brazed into segments. This construction was carried across also to 100, 200 and 300 MW units in the 1950s. On North Tees C, a single radial sealing fin was used to supplement the axial seals, fig.101a – a feature which was introduced on other units in 1939. From Skelton Grange A onwards, an additional fin was machined integrally with the shroud to form a more effective labyrinth seal, fig.101b. In larger turbines, which used wider blades, the no. of sealing fins was increased further to reduce the tip leakage rate.

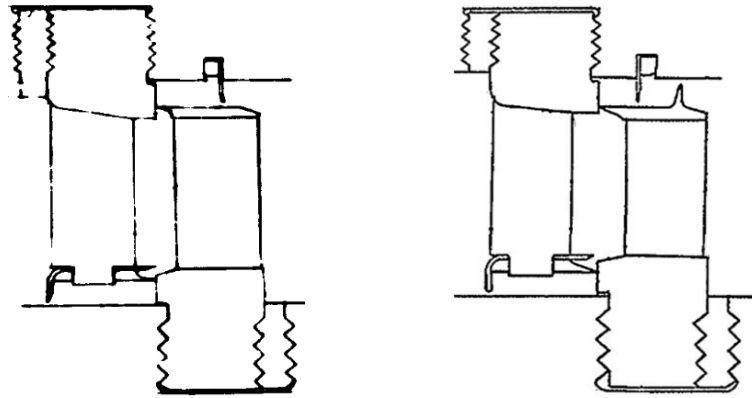

Fig.101 IFR type reaction stages used in the initial stages of
a North Tees C, *left*, and *b* Skelton Grange A, *right*

A key concern during the 1940s and 50s was the ability to design horizontal joint flanges for casings with much higher steam pressures than in the past. Parsons tested scale model HP turbine casings with conventional bolted flanges and with a new type of closure (clamps) using water up to 2,600 lbs/in² gauge (179 barg) and steam up to 1,500 lbs/in² gauge 1000°F (103.4 barg 538°C). It was found that the clamped design could withstand pressures up to around 1.5 times the capability of a conventional joint, so this was employed on the 60 MW sets of the 1940s – 60s, figs.102a to c.

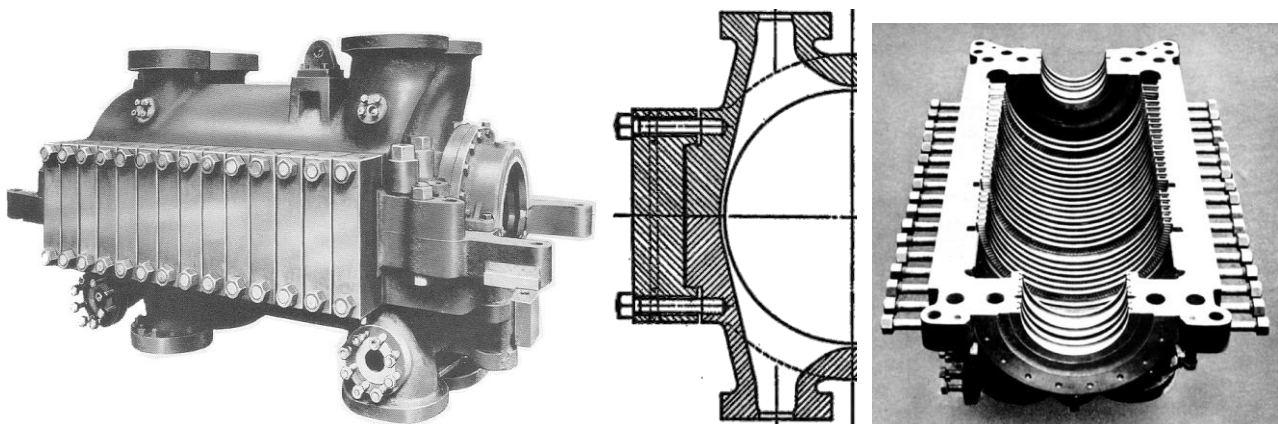

Fig.102a External view of the new clamped HP turbine casing (without bypass governing in this photo), *left*, fig.102b transverse cross-section through the inlet belt (the clamps engaged on faces tapered at an angle of 8°), *middle*, and fig.102c view on the casing joint (a turbine with bypass governing in this case), *right*.

The casing itself was almost uniformly circular, but the clamps added considerable mass on the sides. To counteract the thermal inertia of the clamps, steam was routed through all of the clamps – a system which would be implemented also on flanged casings and would be used on all large units until the mid-1970s. Each clamp required only two 1.75” (44.5 mm) diameter bolts in place of the 5” (127 mm) bolts which were expected to be needed if a traditional flanged joint had been used.

With much higher pressures, a different type of steam chest was required, fig.103. In this design, the plate type emergency stop valve of the 1930s was replaced with a hemispherical valve of small diameter to reduce the valve actuator size and the solid double beat governor valves were replaced by the earlier type of hollow double beat design to produce a better casing geometry and to avoid valve leakage if the casing deformed. With a higher valve throat velocity, a diffuser was provided for the ESV.

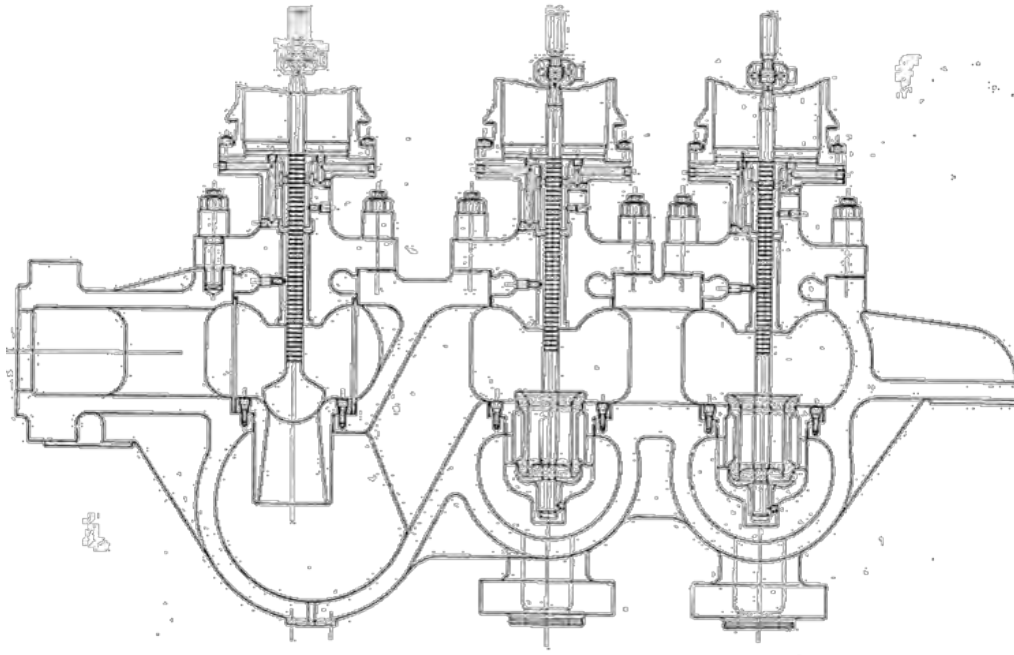

Fig.103 North Tees C and subsequent 60 MW steam chests

With thicker (and hence stiffer) pipes needed at the higher conditions, Parsons started using two steam chests per unit with four long loop pipes symmetrically arranged to minimise forces which could affect machine alignment, fig.104.

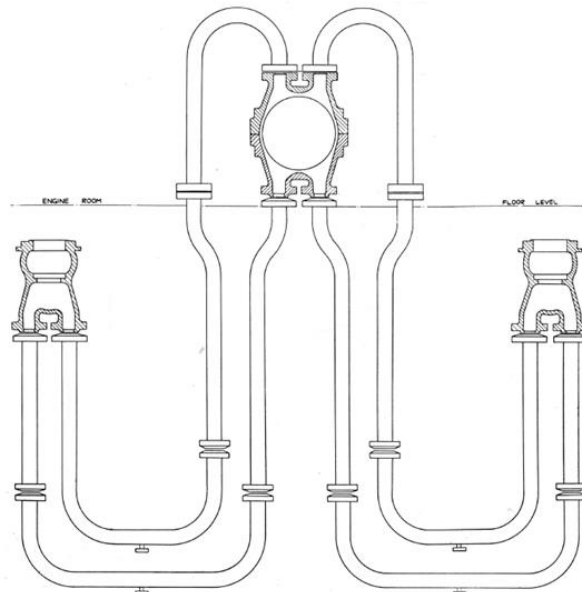

Fig.104 The steam chest and loop pipe arrangement used on 60 MW sets

Once the BEA was formed, the steam conditions for 60 MW units were standardised at 900 lbs/in² 900°F (62.1 barg 482°C). It was also decided to eliminate bypass governing and revert to throttle governing. The reasons for doing this were as follows:

- Bypass governing had primarily provided benefit in the days before the National Grid when units had to pick up the load of tripped machines in the local district unassisted.
- Bypass governed machines were usually designed to be most efficient around 80% load and so produced slightly worse performance at full load.

- The metal temperature at the bypass inlet increased suddenly when the inlet opened which could incur a thermal shock especially in machines with three inlets.

With a Grid of much greater capacity being developed, spare power was expected to be available on the system for sudden load pick up plus it was intended to focus on two-shift operation and fast starting in future rather than running each unit up and down in load each day and maintaining low load on machines overnight.

Quick starting and two shifting trials were carried out on the 50 & 60 MW fleet in the 1950s. Issues were encountered such as water carry over from the boiler which could wreck HP turbines, so plans were established to develop an effective two shifting ability within the industry. The 60 MW units were the workhorses where these lessons were first learned. In addition, they were the first, 'high temperature' units. In other words, thermal fatigue cracking occurred in some machines which provided information of key importance for later designs. More than this, two major decisions were made within the industry. Firstly, the first machines of each new type were to be subjected to quick start and two shifting trials. For Parsons units, this started with the Ferrybridge B 100 MW units in 1957 and continued up until the Fawley 500 MW sets in 1973. Secondly, the CEGB and the major manufacturers agreed to work together on materials development and the investigation of creep, thermal fatigue, stress corrosion and other mechanisms until these were well understood and predictable. This joint working continued from the late 1950s until at least 2000. It produced considerable valuable data including thermal fatigue calculation methods which became highly refined and dependable by 1984. It was known that other countries were building more advanced plant eg in America, GE and Westinghouse were producing turbine designs for conditions up to 5,000 lbs/in² gauge 1200°F (345 barg 649°C), so in the UK, there was considerable investment in developing technologies eg welded HP turbine rotors composed of Nimonic 75 joined to 1 CrMoV. This example did not go into service and such elevated conditions did not become commonplace, but there were spin-off gains for more conventional machines.

Once quick starting was adopted, the issue with the claw couplings became evident. Friction forces affected the HP turbine rotor if full load was achieved before the shaft had expanded fully. Modifications were attempted to improve this which included larger diameter couplings, low friction sintered material on the sliding surfaces and larger thrust bearings to help carry the residual load. By the time this became apparent, the Ferrybridge B 100 MW units had been built and these showed the behaviour most clearly, so it was decided to discontinue the use of end tightened blading and claw couplings for all new large machines and restrict its use only to smaller sets.

Parsons 60 MW units were ordered for 9 additional power stations in the UK. Orders were received also for the largest power station in Africa, Taaibos PS (equal in size to adjacent station Highveld PS which used Brown Boveri sets), and also for Wilge PS and in Australia Wangi PS. These used the 85", 90" and 95" tip diameter exhausts between 1950 and 1958.

In 1955, the CEA ordered two 60 MW two cylinder turbines for Little Barford PS, figs 105 and 106. The HP turbine used a Curtis stage at inlet to drop the steam conditions from 900 lbs/in² gauge 900°F (62.1 barg 482°C) to 520 lbs/in² abs 786°F (36.0 barg 419°C) in one step and so reduce the stage count avoiding the need for an IP turbine. This also allowed the use of a casing with a conventional bolted joint. This became the standard configuration for all subsequent Parsons 60 MW machines. In the UK, the units were always throttle governed, but in overseas units, the Curtis stage was employed for nozzle governing.

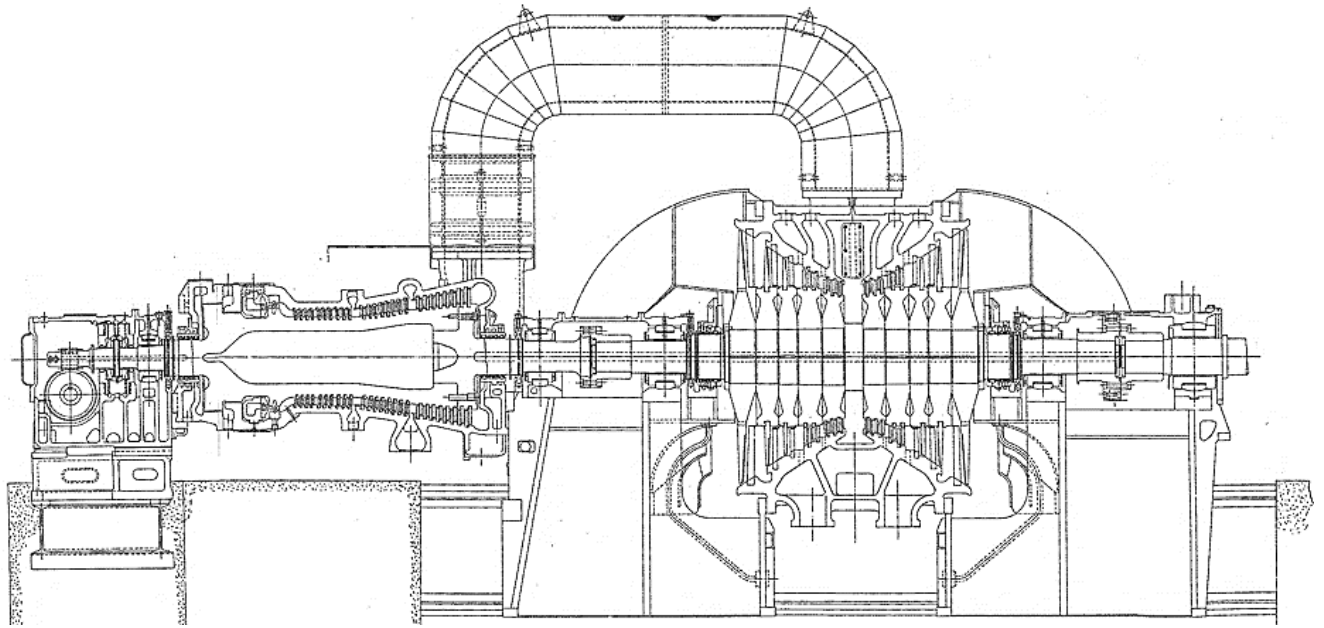

Fig.105 Little Barford 60 MW 3,000 revs/min turbine 1955

In 1964, a trial row of titanium blades was installed in one of the Little Barford units. Titanium was an attractive material because its density was 43% lower than steel while its strength was comparable with the strongest blade steels. This allowed longer last stage blades to be made for future machines. Alternatively, wider blades could be designed to reduce the no. of blades per row and / or better aerofoil shapes could be developed before reaching mechanical limits. There was initial caution because titanium alloys were thought to be more brittle than steel. However, Imperial Chemical Industries (ICI) produced some very promising alloys in the mid-1950s and so it was decided to make some blades using ICI alloy 314 C (Ti 2 Al 2 Mn).

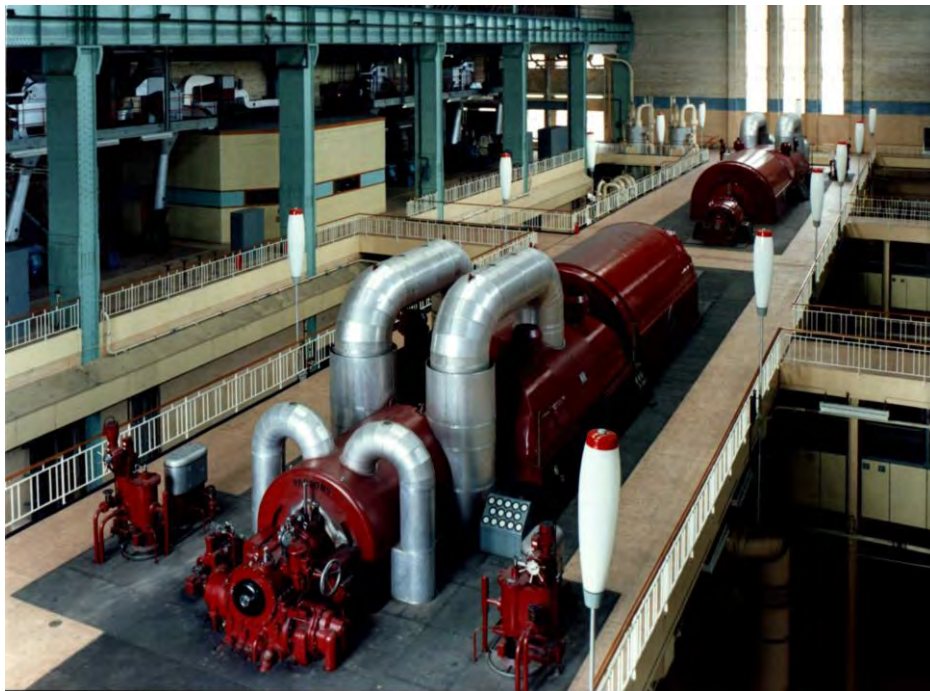

Fig.106 Little Barford turbine hall

Today, titanium (Ti 6 Al 4 V) blades are used extensively and we know that the parent material can withstand water droplet erosion without special protection. In the 1960s, this was not known and it was thought that special erosion shields would be needed. Since conventional shields could not be brazed on to titanium, leading edge protection was provided by depositing a layer of titanium containing 28% Ni 10% Cu. This was unfortunate because the parent material had a good microstructure and properties while the hard layer for erosion protection caused problems.

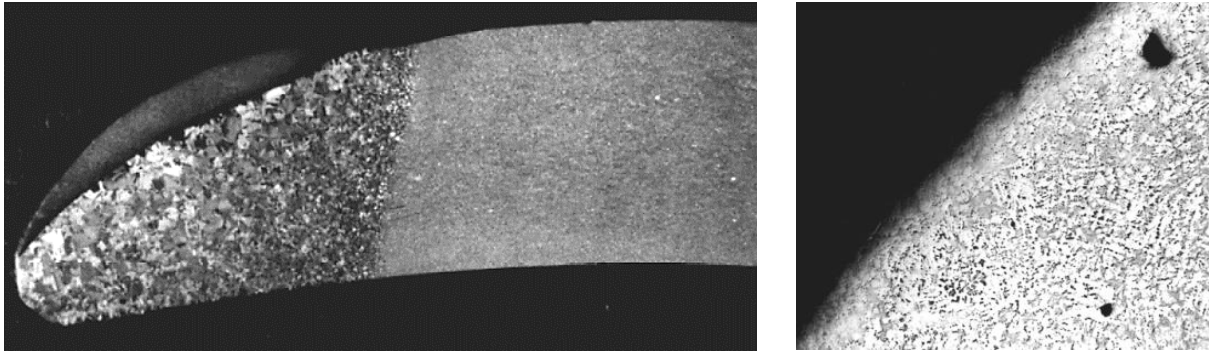

Fig.107a Microstructure of the titanium blades showing the coarse transformed region under the weld deposit at the leading edge, *left*, and fig.107b the microporosity in the weld metal, *right*.

After 2,758 running hours and 158 starts, two blades broke and five other blades were found to be cracked. The cracks had initiated in the hard facing and had extended up to 80% of the way across the blade chord. Even with such large cracks, the blades had not failed in a brittle manner but remained ductile with plastic deformation before the top part of the blade detached. The weld deposit transformed the parent material around the leading edge into a structure similar to coarse martensite ie hard and brittle while the weld deposit contained macro-size pores plus microporosity between the grains, figs 107a and b. The cracks almost certainly started from porosity and then grew by high cycle fatigue through the underlying coarse structure. If the weld deposit had not been used, the blades might have been highly successful. Parsons did not try any more Ti blades (until the 1990s) due to this failure and the fact that early alloys had low impact properties (Charpy impact energy was typically 20.3 J).

In 1969, an LP turbine rotor burst due to fracture of a rotor disc on an 87 MW English Electric non-reheat turbine at Hinkley Point PS [10]. A 1.5 mm deep crack had grown by stress corrosion on the disc keyway and then burst by brittle fracture at 3,200 revs/min during an overspeed test. This led to a worldwide review of rotor disc safety by all manufacturers including Parsons. A UK investigation was launched by CEGB in 1972 and simultaneously, Parsons informed all overseas customers which might be at risk.

CEGB attention focused first on the largest machines since these may have been at greatest risk. One LP turbine rotor from a Parsons 500 MW set at Ferrybridge C and one from an English Electric 200 MW set at High Marnham were dismantled. No cracks were found. Checks on 60 MW sets followed almost immediately. Cracks up to 12 mm deep were found in the 2nd and 3rd discs per flow in Marchwood Unit 4 - an English Electric 60 MW set with 116,000 running hours completed. Cracks were subsequently found in other Marchwood rotors. In November 1972, cracks were found in discs in Bradwell Unit 5, a Parsons 52 MW non-reheat Magnox nuclear unit. The cracks were 0.8 mm deep or less. Overseas, Parsons rotors at Camden were examined and cracks were found there also. At the sister station, Hazelwood, hot steam was injected into the inlet region close to the shaft to try to dry out the disc bores.

By February 1973, more cracks were being found. The inlet discs were more at risk than the exhaust end discs because they ran hot and wet rather than cold and wet. With large numbers of non-reheat sets showing cracks, the CEGB started instructing stations to operate with the first 3 discs per flow removed (2 discs per flow on GEC impulse turbines) leaving the exhaust end discs and blading in place with orifice plates in the LP inlet pipes to maintain the correct pressures upstream. The instruction was subsequently changed to 2 discs per flow because there was a concern that the temperature of the last stage LP blades could increase to 180°F (82°C).

There were 52 non-reheat units in the Parsons CEGB fleet with construction which could be susceptible to cracking. By October 1973, 63% of all non-reheat LP rotors examined were found to have cracks (all manufacturers). The CEGB & SSEB decided to replace all of their 60 MW LP turbine rotors. The new shafts were to have higher toughness discs fitted with no keyways in the bore. When the keyway was removed, the critical crack size (and hence the life of the discs) increased substantially. At the same time, the shrink fit of the discs was reduced which effectively halved the stress at the disc bore. The CEGB ordered 52 new LP turbine rotors to replace all of the Parsons shafts at risk at their stations. These were manufactured between 1973 and the end of 1975. It was a very busy time at Heaton Works! Rotors had to be made to a tight schedule with no slippage.

The units continued to operate with the discs missing until the new shafts were ready. Orifice plates were fitted to simulate the pressure drop of the missing blades to keep the stresses in the upstream stages satisfactory. Initially, one orifice plate was installed in the IP-LP crossover pipe, fig.108. Blade failures in the downstream LP stages started to occur at 5 stations within around 500 running hours. So an 'orifice box' was installed in the LP turbine inlet belt, fig.108, in addition to the plate in the pipe, to create two and then three orifice plates in series. Blade failures still occurred within around 2,000 running hours. Flow traverse and strain gauge readings were taken from units which showed that the flow entering the remaining LP blades was highly non-uniform and disturbed, fig.109.

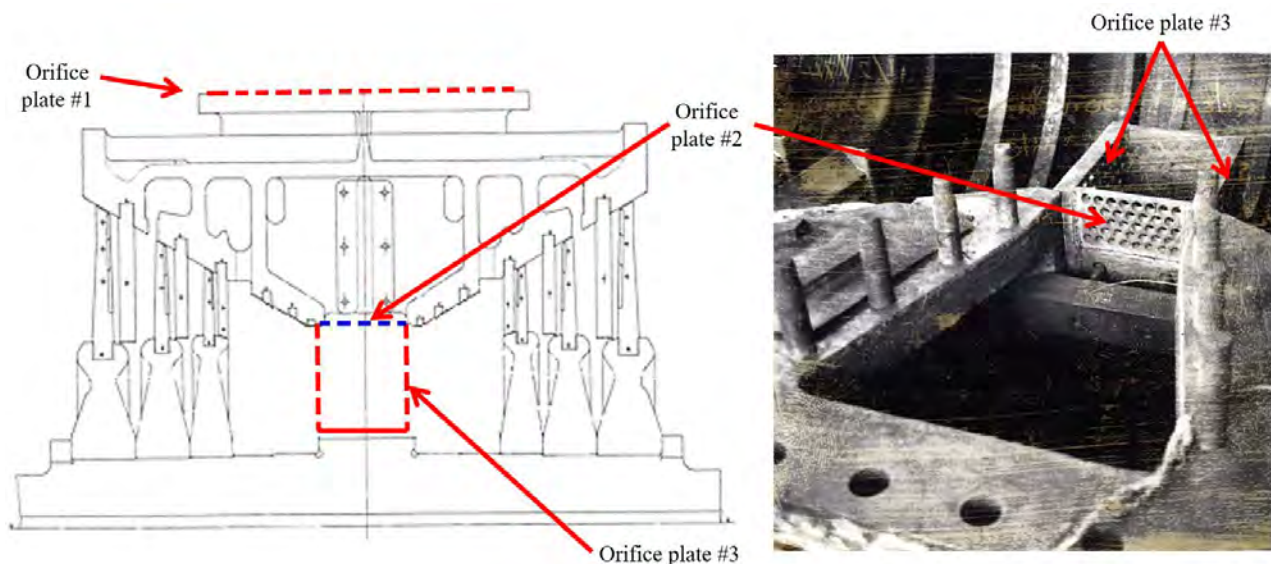

Fig.108 Orifice plates fitted to 60 MW LP turbines to simulate the pressure drop of the blading which was missing when the first two rotor discs per flow were removed

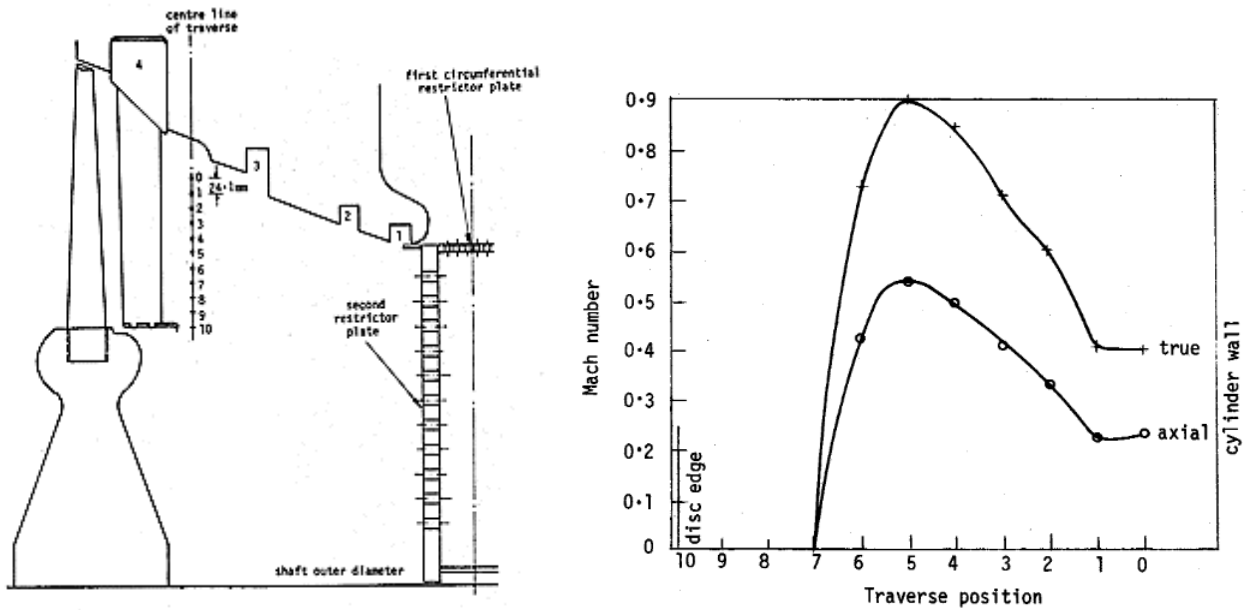

Fig.109 Flow traverse measurements taken on a 60 MW unit at Ringsend PS during the 1970s. The readings were taken at a load of 40 MW as higher loads caused blade failure. 'True' means the absolute steam velocity, 'axial' refers to the axial velocity component. Non-uniform flow existed in the vertical plane but not in the horizontal plane.

Certain lessons were learned:

- Flow did not distribute uniformly even when the orifice plates were highly choked. 75% of the flow could pass through one half of a choked plate.
- Maldistribution still existed when steam changed direction through 90° in the orifice box.
- The steam in the IP-LP crossover pipe was 2% wet. Coarse water collected in pools on orifice plate #1 and then flashed into steam as it passed through affecting the flow pattern.

Due to this experience, Parsons never allowed the use of orifice plates upstream from LP turbine blades in any future situation.

The LP turbines were then operated with all blading removed until the new rotors were ready.

Dunston B high speed 50 MW reheat units

While the first 60 MW units were being built, work proceeded on two 50 MW 3,000 revs/min reheat TG sets for Dunston B PS. Fig.110 shows a comparison between the high speed units and the half speed Dunston units of 1930 to the same scale.

These units were specified by NEESCo (North East Electricity Supply Co – the successor company to the Newcastle-Upon-Tyne Electricity Supply Co NESCO) in 1945 and so employed steam conditions of 600 lbs/in² gauge 850°F (41.4 barg 454°C) reheated at 151 lbs/in² abs to 850°F (10.4 bara 454°C). They were subsequently studied by the BEA as a trial for next generation plant. The first unit commenced operation in October 1949.

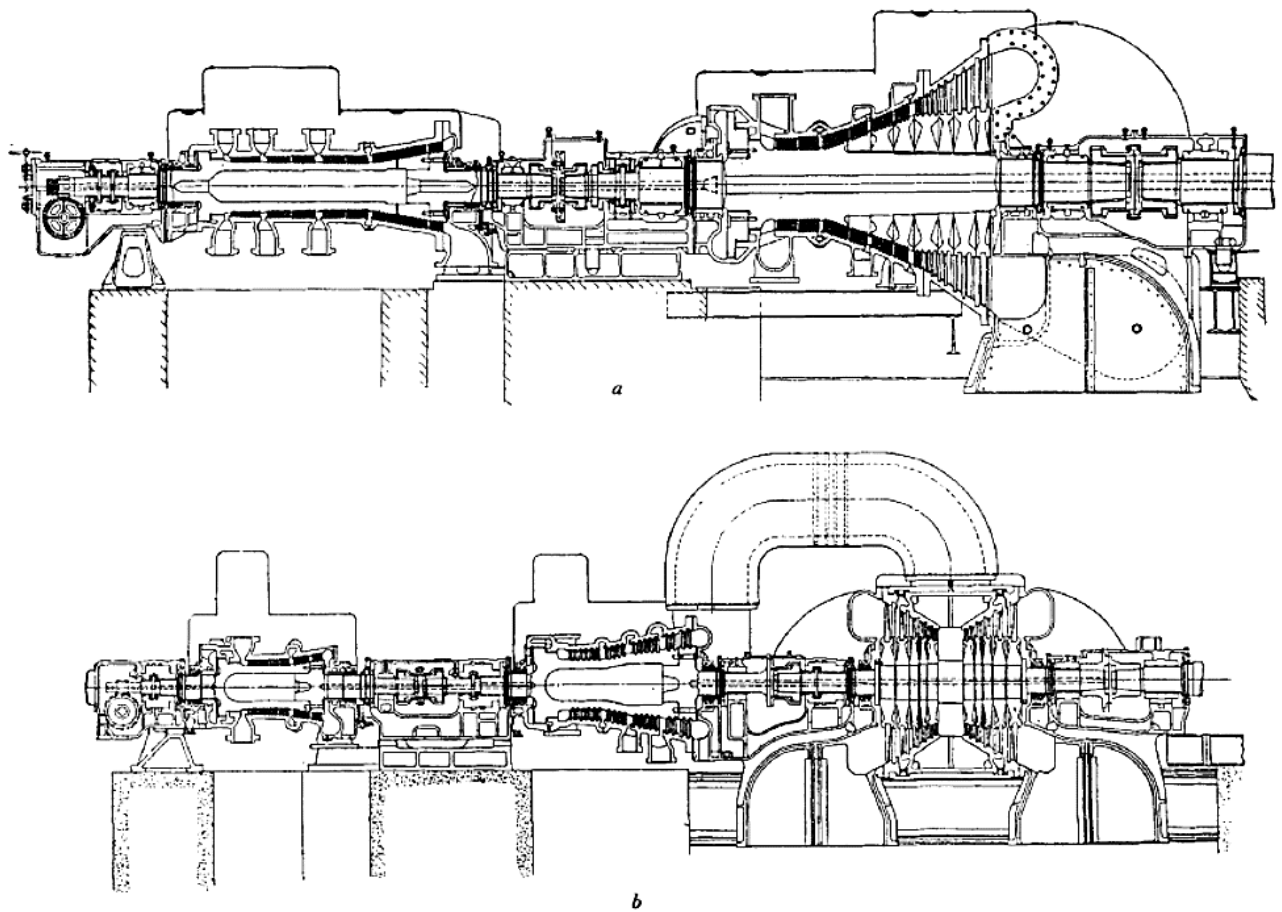

Fig. 2. Longitudinal Section of Turbines
 a Speed, 1,500 r.p.m. b Speed, 3,000 r.p.m.

Fig.110 Comparison between the 3,000 and 1,500 revs/min turbines installed at Dunston B [11]

It was known that new larger turbine-generators would be built in the 1950s using reheat turbines. Previously, many stations operated on a range system ie multiple boilers fed steam into a common steam header pipe supplying all turbine-generators. In other words, any boiler could feed any turbine. This arrangement was difficult with reheat. Instead, it was envisaged that ‘unit construction’ would be used where each boiler was paired with one turbine-generator with dedicated auxiliary systems. This meant that the loss of one shared plant system did not disable multiple units. It also reduced the complexity and cost of engineering the steam and feedwater systems. Unit construction was adopted on Dunston B Units 5 & 6 and this showed that this arrangement was the best choice for future plant.

These units proved to be the most efficient in the UK at the time and they had the advantages of fast starting & flexible operation compared with other plant and the ability to produce power well above their rated maximum output [11].

Parsons first 100 MW turbines

In 1906, the Hydro Electric Power Commission of Ontario (HEPC) was created to manage the generation of electricity in Ontario using water from Niagara Falls and to transmit the power to 16 municipalities including Toronto. Subsequently, power came from additional hydro and thermal power stations and the system grew until HEPC provided power to all of Ontario. It was the World’s first publicly owned electric utility, and for a very long time, HEPC was the World’s largest public power utility.

After World War II, there was a massive demand for electricity, with a 26% pa increase in the use of electricity for some sectors of the market in Ontario and an overall all-time-high peak demand in October 1946 [12]. Up until this time, power came primarily from hydro-electric schemes. Three new hydro projects were launched after the war, followed soon by five more. Around 500 MW extra capacity was added by 1950, but this wasn't enough. In November 1947, a form of rationing was introduced for industrial users. In 1948, demand continued to grow but supply was affected by low water levels at the hydro stations until the Spring thaw released water.

HEPC decided to build two large thermal power stations to help handle the peak power demand and supplement the system at times of low water at the hydro stations. The first plant was J Clark Keith GS at Windsor with a capacity of 264 MW and the second was Richard L Hearn GS in Toronto with an initial capacity of 400 MW growing by 1961 to a total of 1200 MW. All of the turbine-generators at RL Hearn GS were supplied by Parsons.

In 1949, the vast majority of the electricity produced in Ontario was 25 Hz AC – the original grid frequency when power was first generated using water from Niagara. The huge growth in demand led to the need to connect to power systems in adjacent Provinces and States importing and exporting electricity at 60 Hz. After extensive studies, it was decided to start converting the electricity system from 25 Hz to 60 Hz. This started in 1949 and most of Ontario changed to 60 Hz by 1959 (the 25 Hz system was finally switched off in 2009).

Four 100 MW units were ordered for RL Hearn GS. Unusually, Units 1 & 3 were specified to be capable of generating power at 25 Hz using a two pole generator rotor running at 1,500 revs/min and at 60 Hz with a four pole rotor running at 1,800 revs/min. Units 2 & 4 were to run at only 1,800 revs/min. The turbines were designed to be capable of running at either speed.

With a rated top speed of 1,800 revs/min, the turbines were dynamically equivalent to units of just 36 MW at 3,000 revs/min ie the turbines ran at low stress levels. The machines may have been the most powerful Parsons had built up to this time, but the turbines did not push technology limits.

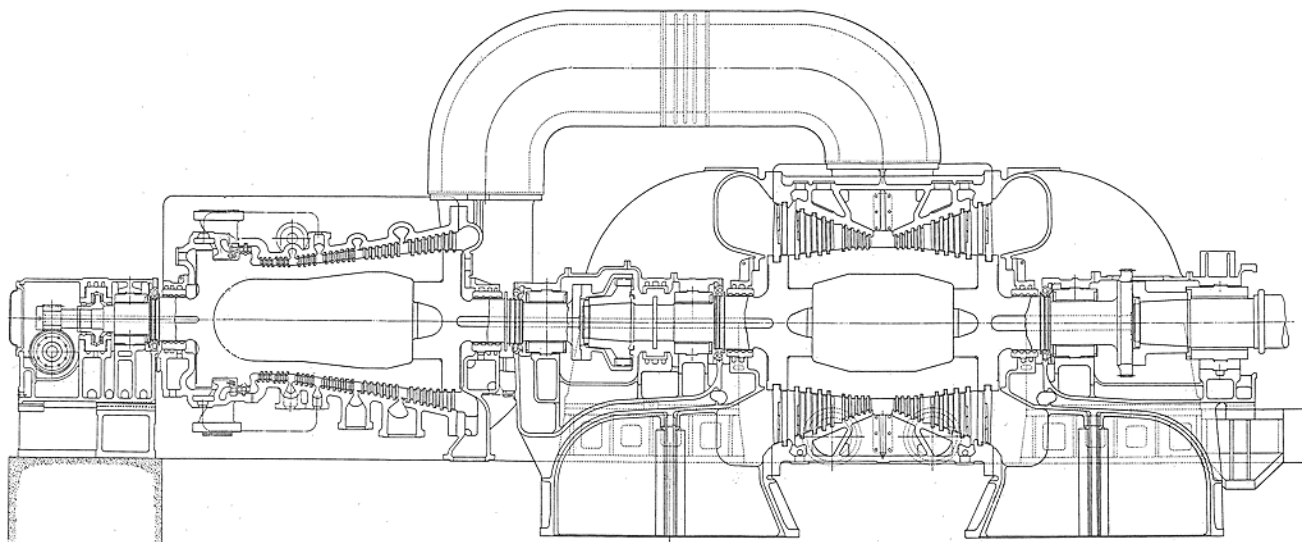

Fig. 111 RL Hearn GS 100 MW dual speed 1,500 / 1,800 revs/min non-reheat turbine 1949

Fig.111 shows a cross-section through the machine. With steam conditions of 850 lbs/in² gauge 900°F (58.6 barg 482°C) non-reheat, the materials were essentially the same as the 60 MW units ie carbon 0.5 moly steel was used for the high temperature rotor, casings and pipes.

A key design issue was how to keep the casings closed when the units were physically very large and operating at high pressure. It was decided to use a Curtis stage at inlet to drop the steam conditions to 563 lbs/in² abs 828°F (38.8 bara 442°C). These values were lower than the conditions inside the Dunston B 1,500 revs/min turbines of 1930 and so it was known that the casing would be satisfactory. The Curtis stage was also used for nozzle governing to raise the part load performance, it reduced the stage count on these slow speed machines and it dropped the temperature substantially which was an advantage for thermal stressing in units which were intended for peaking duty only (base load would always come from hydro units) with up to three starts per day.

On high speed units, the Curtis stage incurred a performance penalty since it produced power output at an efficiency of only 75% at best. At RL Hearn, the impact was much less. Since the unit ran at half speed and the design manager specified low stage loading, this stage produced only 7.6% of the total power. The first 16 reaction stages were end-tightened which helped to raise the efficiency. No issues with the claw couplings were reported because the large diameter couplings reduced the forces acting on the sliding faces.

The shaft diameters were approximately 1.5 m (HP) and 1.6 m (LP), so monobloc forged shafts couldn't be obtained. Hollow and stub construction was therefore used which benefited expansion behaviour, shaft quality and bearing loads. This was the only large Parsons land turbine which used a hollow LP turbine rotor, although this construction was used in large marine turbines. These were also the only Parsons units of 100 MW or larger to use cast iron elephant's trousers LP exhausts. All subsequent units would use fabricated steel exhaust hoods.

The reaction blades were 600 series type with shrouds on HP stages 1 to 16 and open tipped, laced blades downstream. The last stage blades were 22.15" (562.6 mm) long with a tip diameter of 100.3" (2.55 m).

Fig.112 shows one of the turbines in manufacture. Fig.113 shows the first machine at site in 1952.

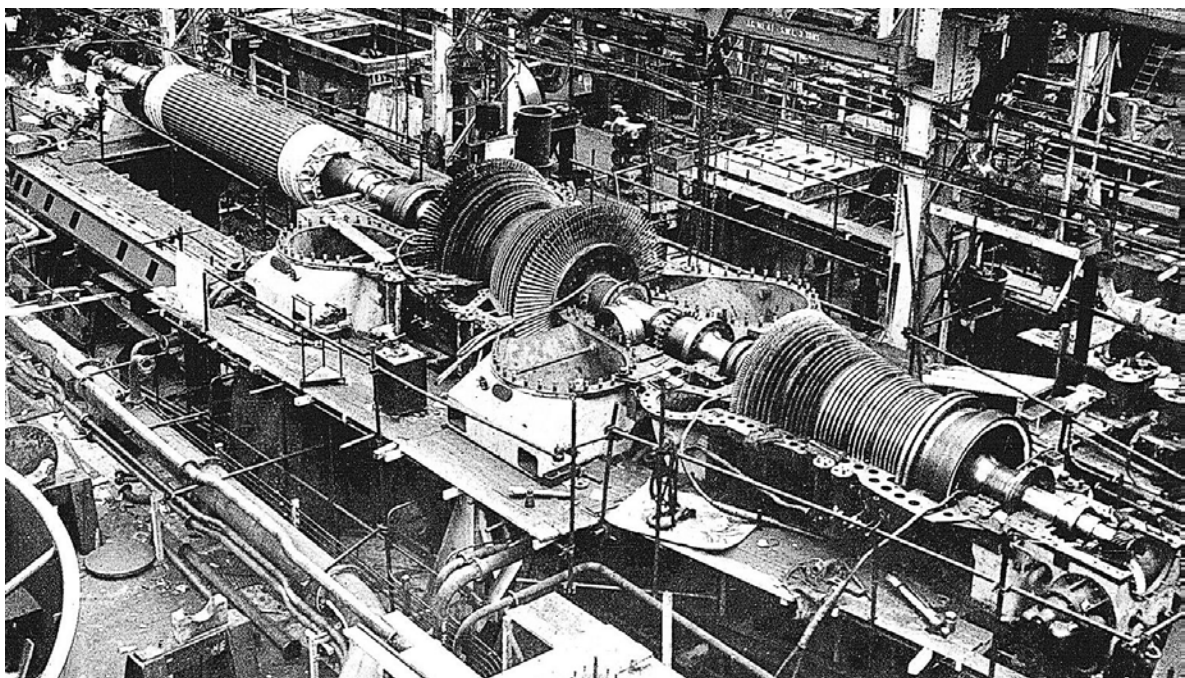

Fig.112 An RL Hearn 100 MW TG set at Heaton Works

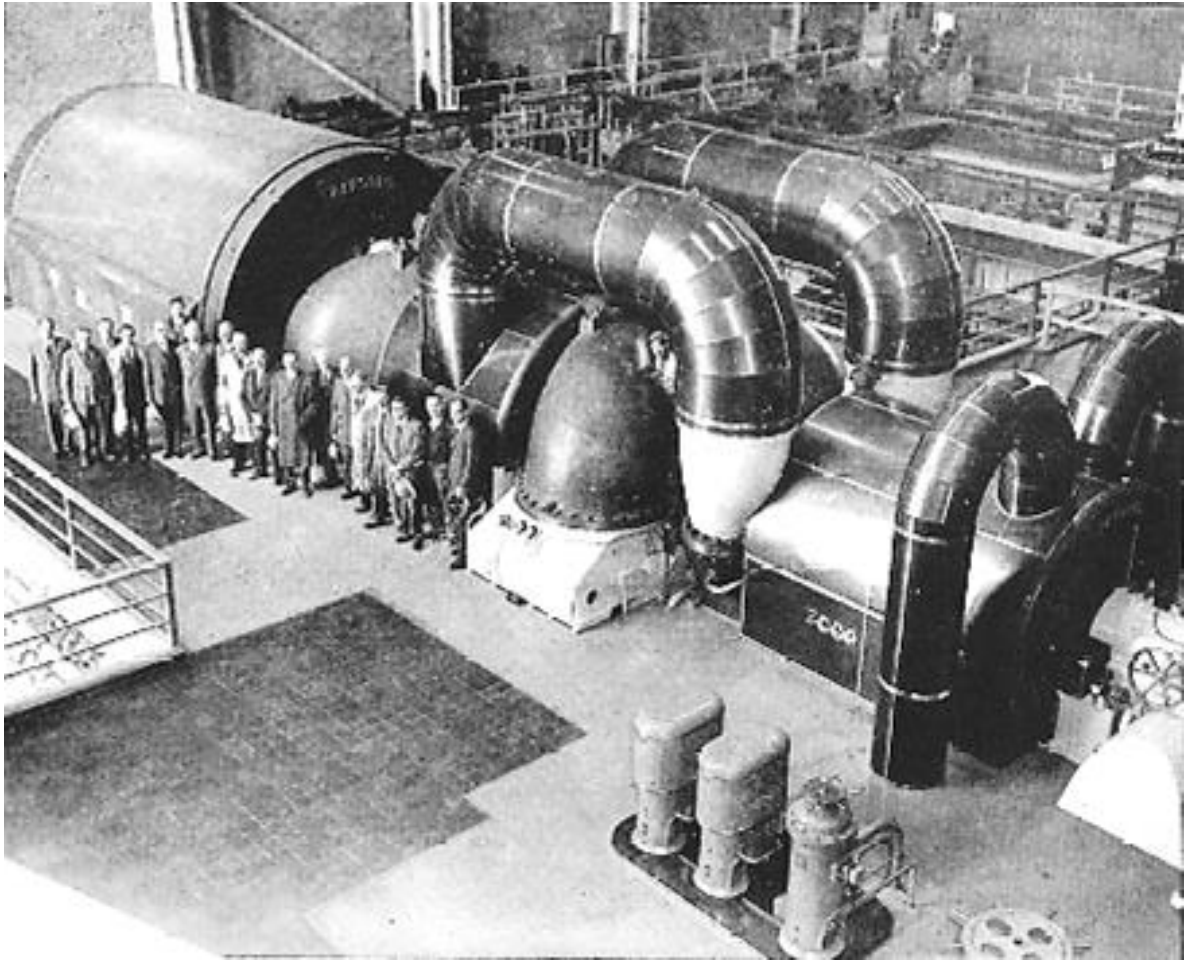

Fig.113 The first 100 MW unit commissioned

Parsons 100 & 120 MW reheat turbines

On 22nd August 1951, the BEA ordered three 100 MW reheat TG sets for Ferrybridge B PS. These required a completely new type of HP turbine and stronger materials.

The HP stop valve conditions were 1,500 lbs/in² gauge 975°F (103.4 barg 524°C) and there were 6 stages of feedheating. To keep the stage count manageable and to allow the horizontal joint to be designed with confidence, a Curtis stage was used at the HP inlet. This reduced the steam conditions to 800 lbs/in² abs 842°F (55.2 bara 450°C) in a single step. The nozzle chests were closed at the horizontal joint, so the casing joint was subjected only to the reduced conditions ie no higher than the 60 MW HP turbines, and arguably, a single shell casing with horizontal joint clamps could have been used. In practice, a double shell casing with conventional horizontal joint flanges was employed which shared the pressure load between the inner and outer shells and allowed cooling by passing exhaust steam through the space between the casings. This was considered to be a better design for two-shifting and rapid starting. This was the first time that a double cased HP turbine was used on a Parsons turbine.

The higher temperature required stronger material, so forged and cast 1 CrMoV were used for the hot parts. The inlet blading was made from 12 CrMo steel – the same as the 60 MW units. The IP stop valve conditions 400 lbs/in² abs 950°F (27.6 bara 510°C) required similar materials, but only single shell construction was used for the IP turbine casing.

Since the tallest available LP blade was 22" long (561 mm) with a tip diameter of 95" (2.41 m), it was decided to use three exhaust flows. One exhaust flow was incorporated in the IP turbine with a last stage blade 16.434" long (417.4 mm) and a tip diameter of 75.16" (1.91 m) while the double flow LP turbine used the 22" blade. The use of reheat reduced the exhaust wetness to 8.6% which was an advantage in terms of both efficiency and erosion.

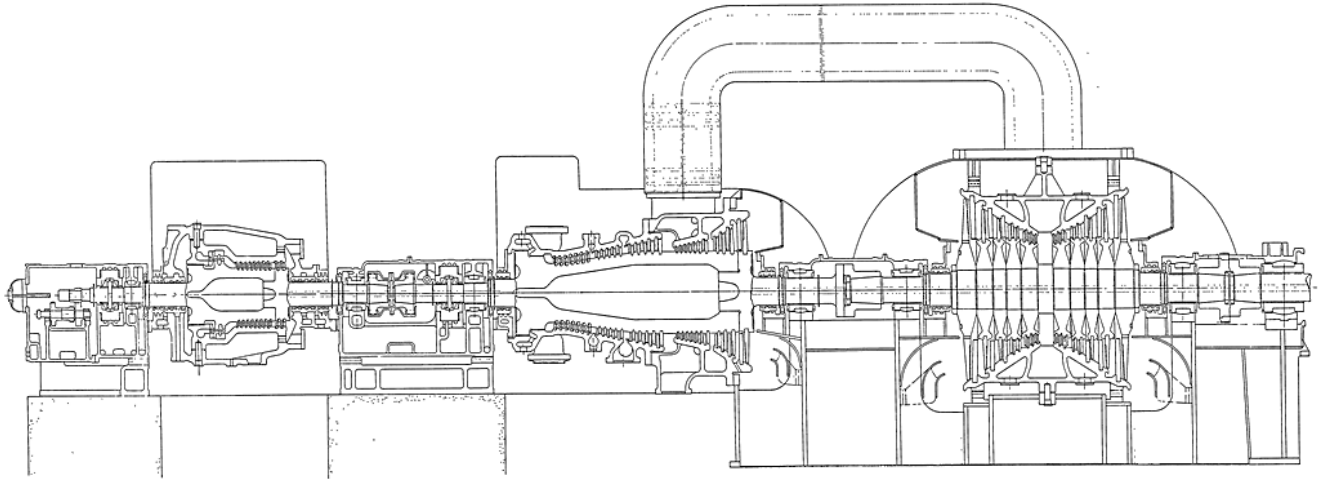

Fig.114 Ferrybridge B 100 MW 3,000 revs/min reheat turbine 1951

The arrangement of the machine is shown in fig.114. The HP turbine used end tightened blading with a claw coupling. This suffered stiction as described earlier and so these units were the last 100 MW class Parsons turbines to use end tightening. After this, solid couplings and fixed thrust bearings were used. The LP turbine rotor employed discs made from 3 NiCrMoV steel.

All of the HP reaction blades and stages 1 to 7 in the IP turbine were made in IFR (integral formed root) construction. Due to the manufacturing methods of the day, the aerofoils were sweep milled on the edge of the root block, fig.115. The shroud was therefore cantilevered from one side of the blade. The CF pull of the shroud created forces which caused the aerofoil to bend slowly by creep. As the shrouds tilted, the brazed connections could sever, fig.116. Once this was seen, methods were developed quickly to place the shroud centrally relative to the aerofoil which eliminated the issue.



Fig.115 An IFR blade segment



Fig.116 Shroud lifting known as 'crocodile's teeth'

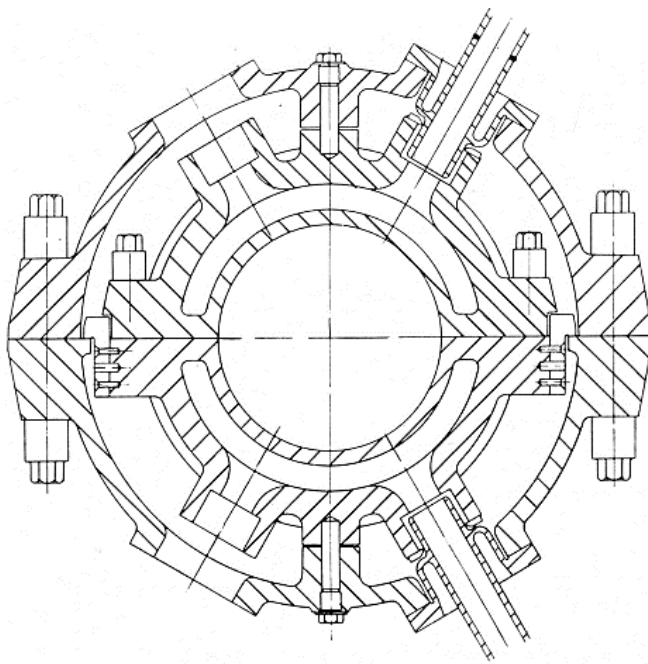

Fig.117 Cross-section through the HP turbine inlets Fig.118 Ferrybridge B HP turbine Curtis stage

Fig.117 shows a cross-section through the HP turbine casing inlets. Double casing allowed each casing wall to be thinner and made the joint flanges more compact. The inlet pipes were arranged at an angle of 30° to the vertical, a feature which would become characteristic of all Parsons double cased HP & IP turbines. This allowed the casing to be more circular than with vertical inlets, even though it made the machining more difficult. This was considered important in the days when casing distortion couldn't be predicted.

Fig.118 shows the Curtis stage moving blades. All CEGB Parsons units of 100 MW or more were throttle governed (this was the CEGB's choice) whereas on overseas machines, this stage would be used to enable nozzle governing. Since the CrMoV steels used for the HP & IP turbine rotors and casings were relatively new ie there was very little creep data, this stage reduced the temperature significantly as an extra margin of safety.

A new style of HP steam chest was introduced, figs.119 and 120.

The new steam chest was open die-forged, made from 1 CrMoV steel and rectangular in outward appearance. The valve chambers had to be machined into the forging. Since these were circular, this led to some uneven wall thicknesses, which was undesirable for thermal stressing, but it was considered important to use forged material at these steam conditions. The top surface of the chest was flat to make the valves easier to access. This was a trend within the industry at the time. This resulted in a convoluted steam path which became the basis for a shorthand name: people referred to this design as the 'Z-shaped' chest. Internally, there was a shared pressure wall between the ESV and GV chambers which became prone to cracking. This was its weak spot. Nevertheless, the chests lasted for typically 150,000 running hours ie 1.5 times the intended design life before needing replacement. The ESV included a pilot valve to give fine control of the run to speed and to reduce the pressure difference which the actuators had to overcome when the main valve opened. Both the ESVs and GV's had hemispherical valve heads and diffusers.

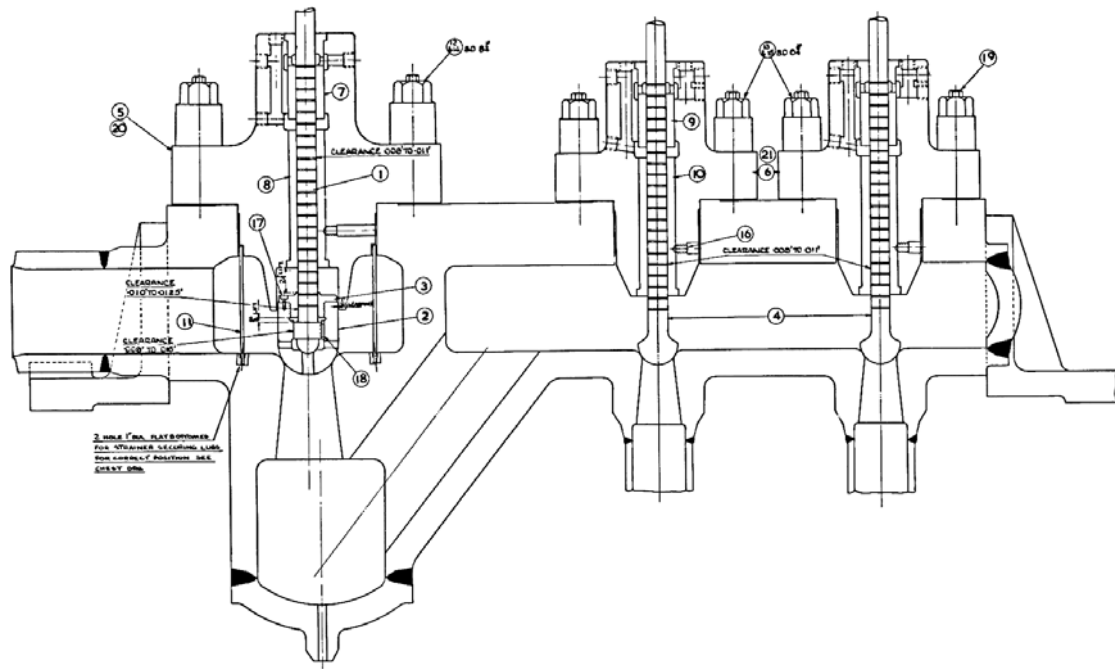

Fig.119 Ferrybridge B HP steam chest

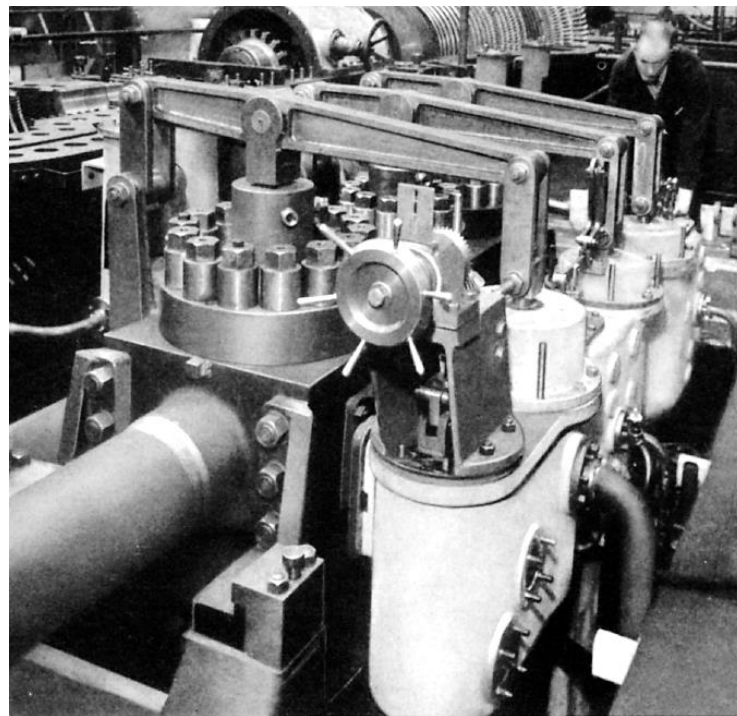

Fig.120 Ferrybridge B HP steam chest with valve actuators and levers installed

The IP turbine used only one valve in each chest (two chests per turbine). This valve was named the ‘intercept valve’ as it was there to stop steam in the reheater from causing an excessive overspeed following trip. This followed the practice on previous reheat turbines, but Ferrybridge B had a new feature. Vent lines were provided from the hot reheat pipes to atmosphere to empty the reheater and HP turbine quickly when a unit tripped. In reheat turbines, the steam in the reheater and HP turbine became trapped when the HP and IP valves tripped shut. Large machines could take

30 mins or more to run down to turning gear speed, and so the HP blading initially span at high speed in stagnant, relatively high pressure steam producing windage heat. This had been permitted in previous machines, but on the 100 MW units, 'reheat release valves' were provided to dump the steam and so prevent potential overheating. This practice continued on all further Parsons reheat units until tests carried out on a 500 MW turbine at Ince B PS in 1984 showed that reheat release valves weren't needed on Parsons turbines below 250 MW at 3,000 revs/min.

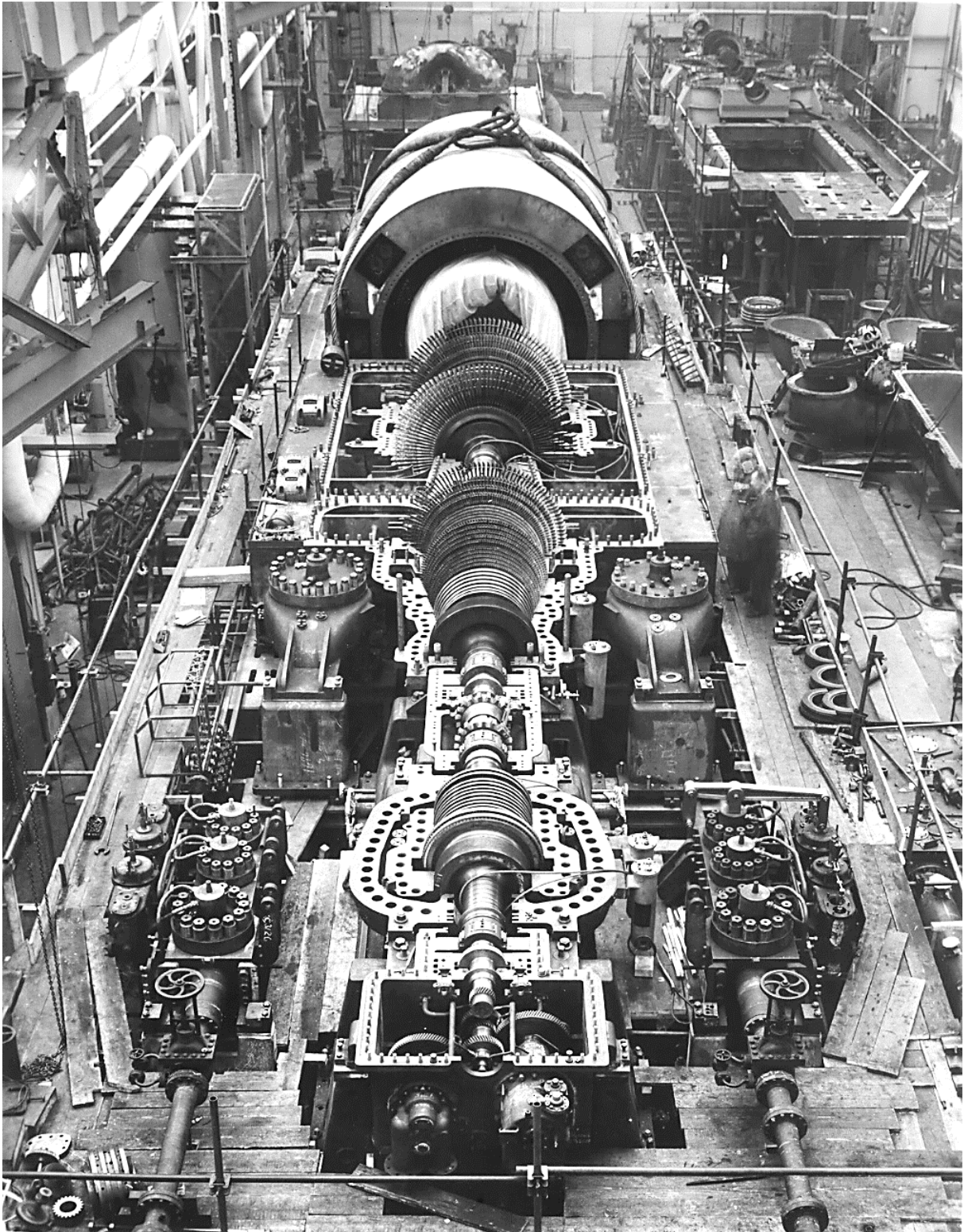

Fig.121 A Ferrybridge B turbine during erection in Heaton Works

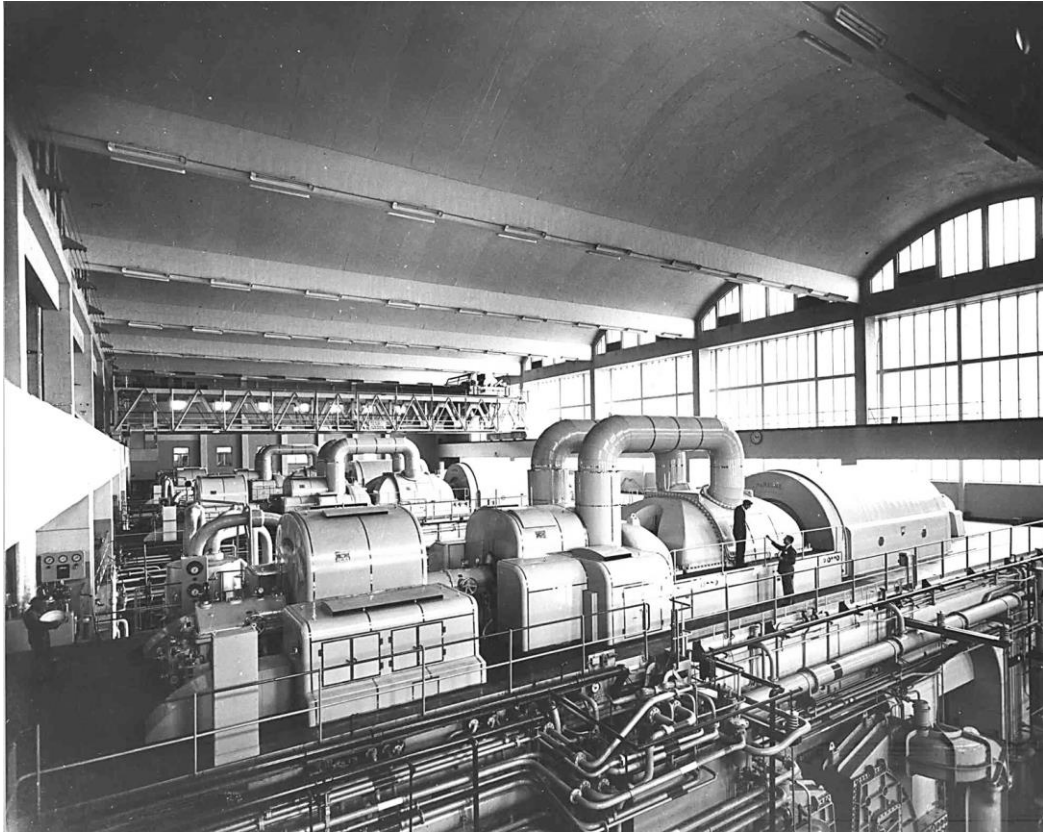

Fig.122 Three 100 MW TG sets in Ferrybridge B turbine hall

Engineering work on Ferrybridge B was completed by 1955. Work started immediately on four 120 MW turbines for Drakelow B which had just been ordered by the newly formed CEA.

The Drakelow B units were essentially similar but they included the following changes:

- Power output was increased to 120 MW.
- The steam temperature increased to 1000°F (538°C) at both the HP & IP turbine inlets.
- A three exhaust arrangement was retained but all exhaust flows used the 95" tip diameter blading.
- End tightened blades with a moving thrust bearing were not used. Instead, a single thrust bearing located the entire rotor train, placed between the HP & IP turbines with solid (not claw) couplings.
- The HP turbine now pointed in the opposite direction to Ferrybridge B ie the steam flow passed from the no.2 bearing end towards the no.1 bearing. This placed the HP and IP inlet stages closest to the thrust bearing. Since axial sealing fins were retained in the HP & IP bladepaths, even though the clearances couldn't be adjusted in service, the chosen cylinder arrangement ensured that axial differential expansion movements and hence wear were minimised in the front stages. The inlet stages of any turbine suffer the highest percentage tip leakage because the steam pressures here are the highest, and with short blading, the tip leakage area is a greater percentage of the total flow area than in later, taller stages. So this configuration gave a small advantage on leakage rate.

A cross-section through the turbine is shown in fig.123. Since the HP and IP rotors were pointed in opposite directions, it was decided to balance part of the HP blading end thrust against the IP blading thrust. This allowed the dummy piston diameters to be reduced, which made it easier to obtain rotor forgings, the stress levels in the shafts were reduced and the leakage rates through the dummy piston seals were lower.

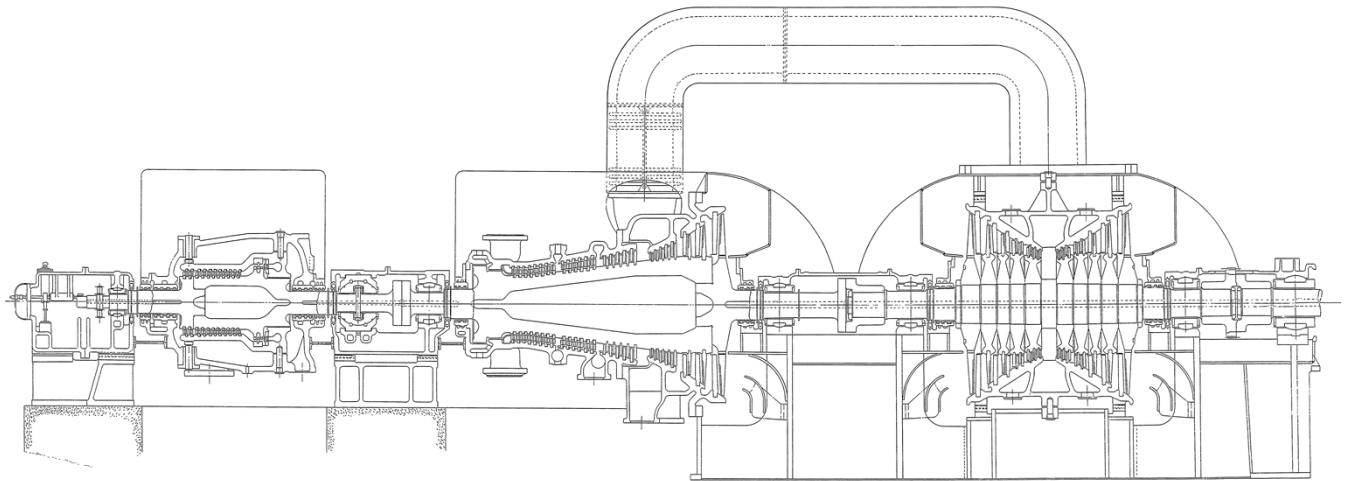

Fig.123 Drakelow B 120 MW 3,000 revs/min reheat turbine 1955

Two flyball governors were provided in the no.1 bearing pedestal at the outboard end of the HP turbine shaft. The main governor controlled the HP turbine inlet valves and the auxiliary governor controlled the IP turbine intercept valves. In one unit, a fault occurred with the auxiliary governor which caused the intercept valves to close while the machine was on load. There was no steam in the IP turbine now, so the IP blading thrust fell to zero. The HP blading thrust was no longer balanced. In addition, the reheat release valves opened, which caused the HP turbine exhaust pressure to fall which increased the HP blading thrust. The force acting on the thrust bearing became high. The white metal was removed which allowed the shaft train to move towards the steam end. The shrouds on stages 1 to 14 in the IP turbine became damaged as the fixed and moving blades came into contact.

Following an investigation, the control systems on subsequent Parsons reheat turbines were modified so that both the main and auxiliary governors controlled both the HP and IP inlet valves – now failure of either governor caused the whole unit to trip. In effect, the main governor controlled the unit up to normal running speed and across its' normal load range. However, if the speed increased by more than 1% above rated speed, then both governors became active such that either governor could close the valves. This ensured that uncontrolled overspeed of a turbine could not occur. Subsequently, a governor was developed which could be used on its own, without an auxiliary governor. In following generations of machines, the HP and IP blading thrusts were entirely balanced by their respective dummy pistons. This principle was maintained in every Parsons turbine after this.

Three identical machines were installed in Kincardine A PS near Stirling in Scotland. Fig.125 shows Unit 3 during assembly in Heaton Works. It can be seen that the LP turbine exhaust hood completely surrounded the LP inner casing. This provided additional flow area to help reduce the losses in the exhaust. The exhausts also included turning vanes. These were used on large machines – especially those with three exhausts or more – to maintain a near uniform steam pressure distribution across the turbine annulus immediately downstream from the last stage blades (and so minimise the risk of fatigue failure in the blades), while allowing the exhaust hoods to be more compact axially and still achieve a good exhaust performance.

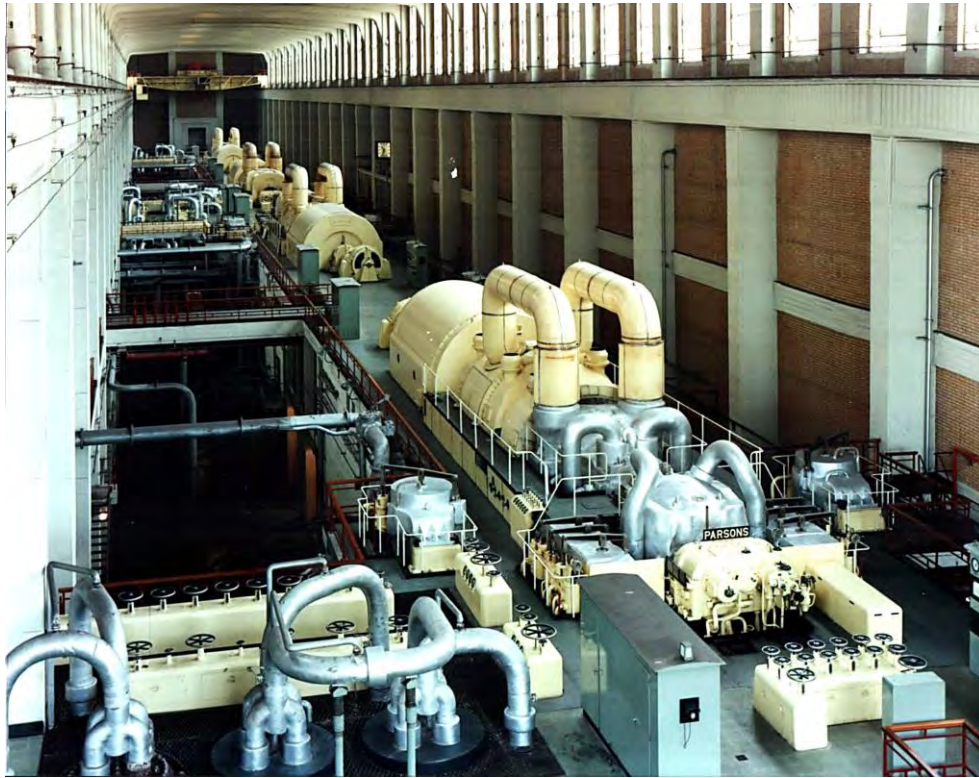

Fig.124 Four 120 MW TG sets in Drakelow B turbine hall

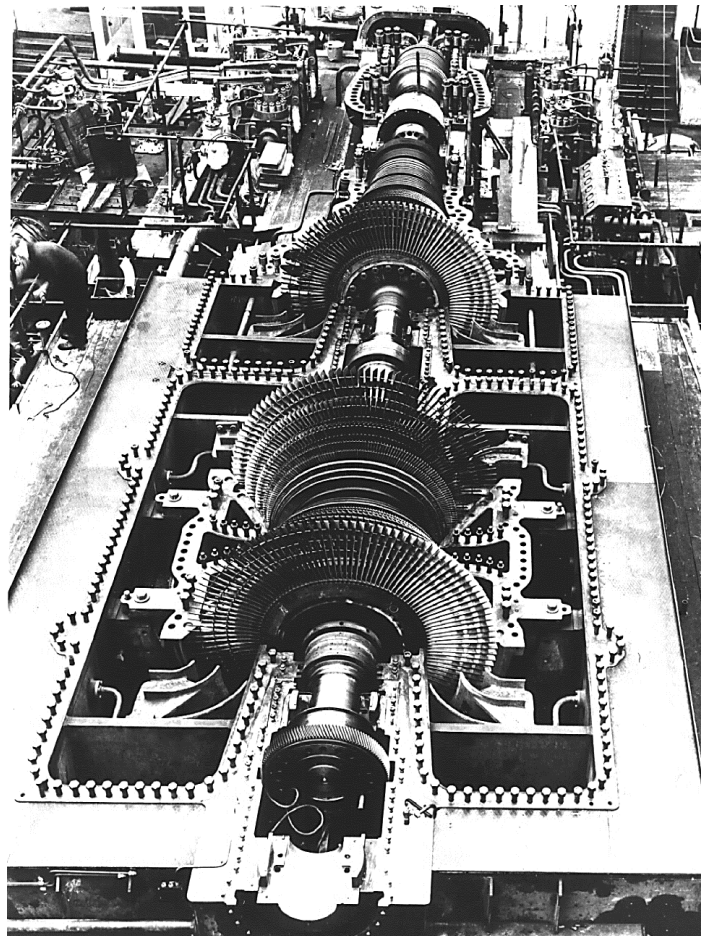

Fig.125 Kincardine A Unit 3 during manufacture showing the LP turbine construction

In parallel with these orders, larger last stage blades continued to be developed. As usual, these were all laced blades mounted on axial fir tree root fixings. A blade 24.7” (627 mm) long with a tip diameter of 102.9” (2.61 m) was developed which allowed 100 MW units with two exhaust flows to be built, and a blade 27.22” (691 mm) long with a tip diameter of 110.4” (2.8 m) was designed so that two exhausts could be used in 120 MW units. These blades were employed in orders starting from 1957 onwards: six 100 MW units for Aberthaw A in Wales, four 120 MW sets for Skelton Grange B and four 120 MW sets for Rugeley A in England followed by overseas sets.

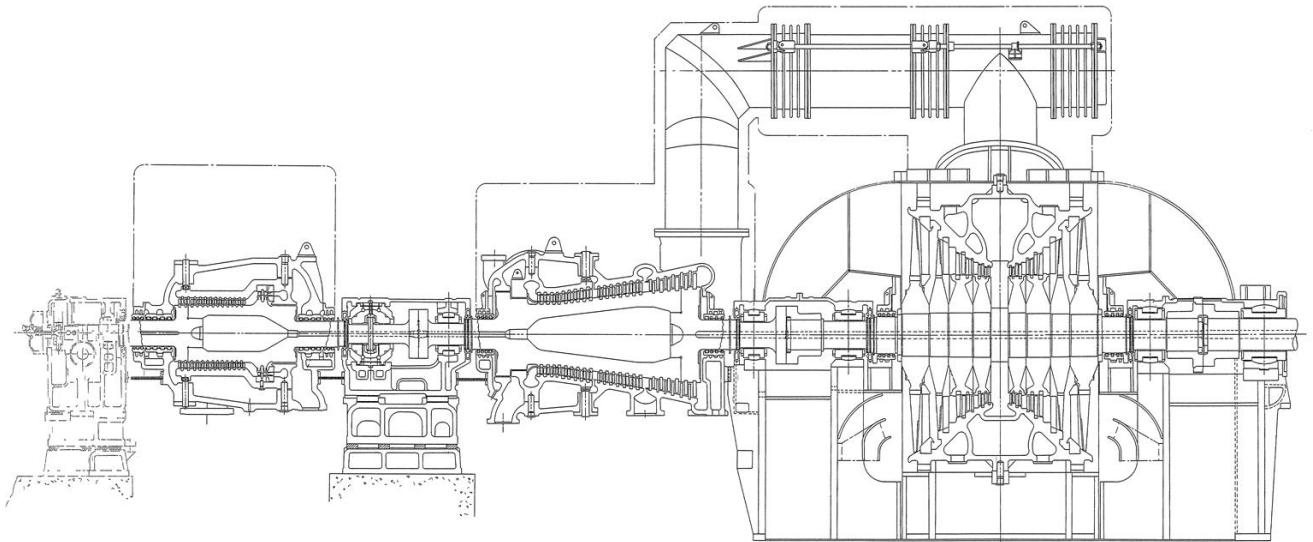

Fig.126 Skelton Grange B 120 MW 3,000 revs/min reheat turbine 1957

Fig.126 shows one of the Skelton Grange B units. It may be seen that the highest pressure feedheat extraction was taken from the HP turbine outer casing close to the inlets. This was done to ensure that sufficient exhaust steam was drawn across the outer surface of the inner casing to keep it cool. In practice, this flow was more than was needed and casing wall temperature gradients could be high. By the 1970s, this practice was stopped and the flow passing through the shaft end glands alone was used to draw a small amount of cooling steam past the inner casing.

At Skelton Grange, the IP turbine was partially double cased around the inlet region – this was a feature introduced on the West Thurrock 200 MW sets, see later. This was thought to be a good idea as it allowed the IP inner casing to be cooled, but the sudden change in geometry where the double cased section joined the single cased part created high localised stresses. By the 1970s, IP turbines became fully double cased to avoid this.

The HP steam chest was similar to Ferrybridge B except that separate valve seats were fitted from Skelton Grange B onwards. Initially, the seat facings in the Ferrybridge chests were machined integrally with the chest forgings as it was uncertain whether separate seats could withstand the higher valve forces on these units, but by 1957, there was sufficient confidence to fit bolted-in seats which could be stellite for wear resistance and if necessary replaced.

The IP steam chests were totally different on Skelton Grange B and later machines, fig.127. Where Ferrybridge B had used just one valve per chest, the later machines used two valves per chest – a solid hemispherical emergency stop valve and a hollow double beat intercept valve. The steam strainer was in a separate casing under the machine. This design of reheat steam chest was employed on subsequent large units up to 500 MW, see later.

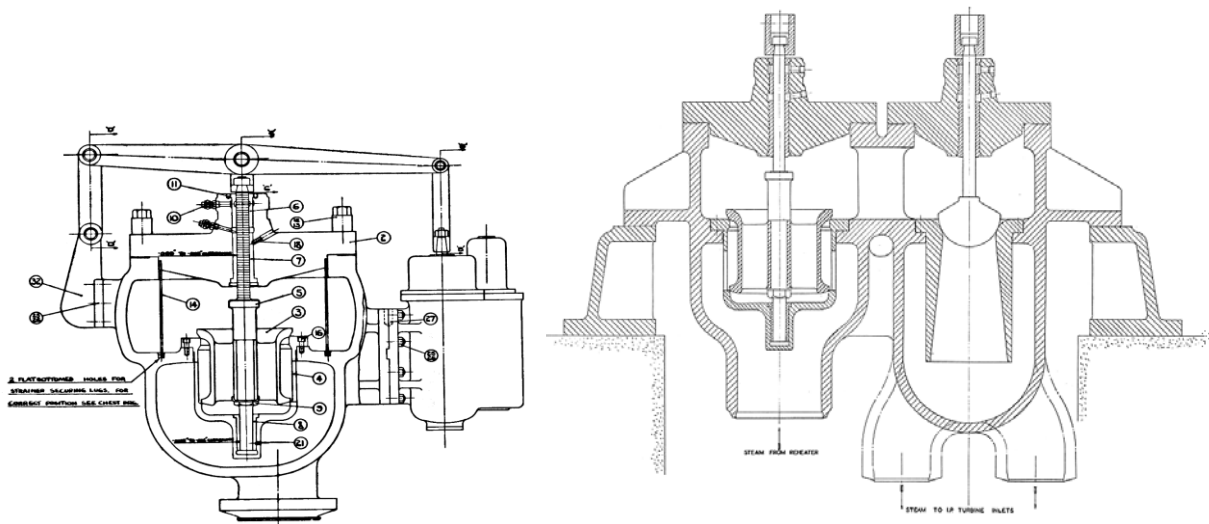

Fig.127 Intercept valve used on Ferrybridge B, Drakelow B and Kincardine A, *left*, and the combined reheat ESV and intercept valve chest used from Skelton Grange B onwards, *right*.

The family of 100 & 120 MW reheat units took precedence over the 60 MW non-reheat sets for UK power generation, but they in turn were superseded by 500 & 660 MW units in the 1970s. By 1980, the 100 & 120 MW fleet were used primarily for two-shifting and peak load duty completing many stop-starts (over 6,000 starts at one station) which they handled well. So, while the 60 MW sets had been designed primarily for base load use and hard lessons had been learned when two-shifting and quick starting were attempted, the 100 and 120 MW units were the first large, high temperature machines to be designed by Parsons to be capable of flexible, cyclic duty. The extensive trials in their early life demonstrated that the turbines were capable of two-shifting and the stations confirmed this by operating for many more hours and starts than the designers envisaged. All of the Parsons 100 & 120 MW stations in the UK remained in service until 1992 – 1995 ie service lives of around 35 years were completed without major degradation, when power plants were normally expected to operate for only around 15 years at the time the machines were built.

These UK machines were followed by many more 120 MW sets installed around the World in the 1970s and 80s. In these units, a Rateau stage replaced the HP turbine Curtis stage for better efficiency, nozzle governing was used, higher steam conditions were employed and taller last stage blades became available. Many of these later machines were still operating at the time of writing.

Magnox nuclear power plant

While the 60 to 120 MW units were being developed, Parsons became involved in the nuclear industry. In Spring 1946, Sir Claude Gibb held discussions with the UK Atomic Energy Research Establishment (AERE) on the role Parsons could play. Orders were subsequently received to manufacture and install a large DC electromagnet, vacuum chamber and auxiliary systems for an 800 ton cyclotron.

Early nuclear reactors were used only to produce plutonium for nuclear weapons and any heat produced by the reactor was an unwanted side product which was discarded. By 1947, studies were launched at AERE Harwell to see if this heat could be used to produce electricity. The only way to do this was to boil water and pass the steam through a turbine-generator. At a conference in September 1950, it was reported that the cost of electricity from a nuclear reactor could be less than one (old) penny per unit [13]. There was considerable debate about this, but in January 1951,

a team of engineers and physicists at Harwell was established to complete a comprehensive study on the feasibility of producing electricity from nuclear fission. Engineers from Parsons were invited to participate and they remained with the Harwell team until the work was finished in 1953. They concluded that a gas-cooled, graphite-moderated reactor could be built to produce electricity at a cost reasonably comparable with that obtained in a contemporary coal-fired power station.

In April 1953, the UK Treasury approved the plan to develop Calder Hall PS which became the World's first commercial nuclear power station. Parsons supplied a large part of the plant including the turbine-generators, main and auxiliary CO₂ circulators, the principal CO₂ ductwork, main condensers and the dump condensers. The first reactor was loaded with uranium in early 1956 and became critical for the first time on 22nd May 1956. The station connected onto the National Grid on 27th August 1956.

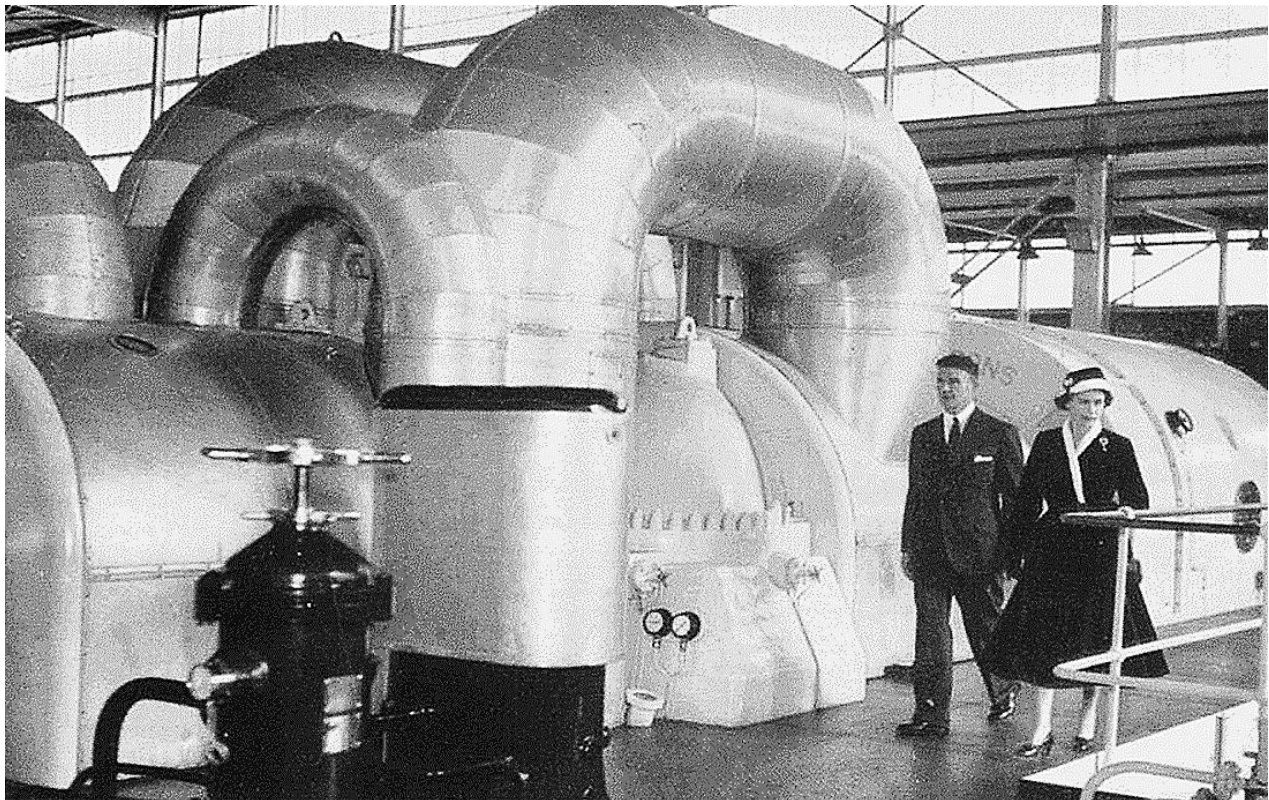

Fig.128 HM Queen Elizabeth II with Mr HG Davey, Works General Manager, Northern Area, UK Atomic Energy Authority at the official opening ceremony on 17th October 1956

The turbine-generators were initially rated at 23 MW each with two units per reactor. They were subsequently upgraded to 27 MW then 30 MW by 1965. A cross-section through the turbine is shown in fig.129. The boilers provided steam at 200 lbs/in² gauge 590°F (13.8 barg 310°C) which entered at the front of the HP turbine bladepath and at 55 lbs/in² gauge 312°F (3.8 barg 156°C) which entered halfway down the HP bladepath. This dual steam supply maximised the amount of heat which could be obtained from the reactor and it helped to control the plant. The higher pressure supply was regulated to achieve the desired power output while the lower pressure was regulated to control the pressure in the boiler and hence the amount of heat taken from the reactor so that the reactor core could operate at constant temperature. There were no feedheat extractions from the turbine.

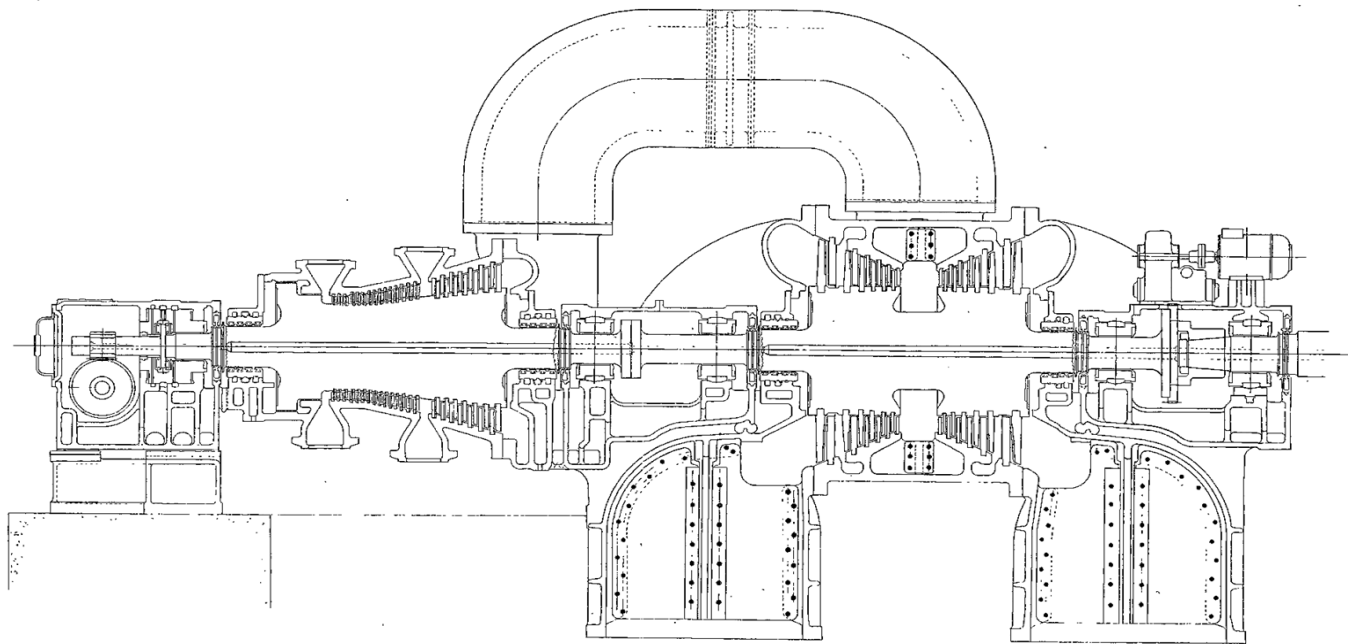

Fig.129 Calder Hall 23 MW (later 30 MW) 3,000 revs/min turbine, designed in 1954

The operating temperature of the uranium fuel was limited to 650°C maximum [13] and the material had a low thermal conductivity, so temperature gradients existed in the fuel rods. Temperature differentials also existed across the walls of the fuel cans, between the cans and the CO₂ gas and within the boiler. These considerations resulted in low steam conditions for the turbines. The steam pressure and temperature were so low, they were comparable with those used between 1910 and 1920, which meant that exotic materials and construction didn't need to be used. The turbine rotors were carbon steel monobloc forgings and the casings were made from carbon steel (HP) and grey cast iron (LP). The HP turbine blades were all 50% reaction and made from 12 CrMo steel. Stages 1 to 15 were end tightened. People were concerned about the exhaust wetness, which was 11.5%, if a large blade was used. For a single flow exhaust, this would have required the 95" (2.41 m) tip diameter blade which had only just been developed. Engineers wanted the lowest possible risk at this station and so it was decided to use a double flow LP turbine with 15" (381 mm) long, 70" (1.78 m) tip diameter last stage blades. The LP blades were made from stainless iron.

These units were successful and two further reactors were built at Calder Hall, so there were 4 reactors and 8 TG sets at the site. A nearly identical station was built at Chapel Cross near Annan in Scotland. Calder Hall remained in service until March 2003 and Chapel Cross until June 2004. The TG sets completed approximately 300,000 running hours each. The only degradation was some erosion of the cast iron LP turbine casing where steam passed over the blade tips plus some erosion of copper locking strip in the LP fixed blade root fixings.

In 1954-55, the UK Atomic Energy Authority (UKAEA) consulted with four major British electrical power groups including Parsons and signed agreements releasing UKAEA knowledge to each group so they could design and manufacture the next generation of British nuclear power stations. A fifth consortium (APC) participated from 1957. Parsons joined together with 7 other companies to form the Nuclear Power Plant Co (NPPC). These companies were: Reyrolle, Head Wrightson & Co Ltd, Sir Robert McAlpine & Sons Ltd, Whessoe Ltd, Strachan & Henshaw Ltd, Alex. Findlay & Co Ltd and Clarke, Chapman & Co Ltd. Parolle – the jointly owned general engineering & contracting division of Parsons & Reyrolle acted as co-ordinators for work within the group.

The stations which each group built are listed in table 3. Each consortium hoped their design would become standard for all subsequent Magnox stations, but this did not occur. The principal criterion for evaluating tenders was the capital cost per MW of electricity generated. This favoured larger power plants, so reactors after Chapel Cross grew rapidly in size as each project emerged. Every station was different with TG sets of ever increasing size and higher steam conditions.

Consortium	Turbine-generators	Boilers	Power stations
Parsons / NPPC	Parsons	Babcock & Wilcox (before NPPC was formed)	Calder Hall, Chapel Cross
		Clark Chapman and Head Wrightson	Bradwell, Latina
AEI-John Thompson	AEI	John Thompson	Berkeley
English Electric Babcock & Wilcox Taylor Woodrow	English Electric	Babcock & Wilcox	Hinkley Point A
GEC Simon Carves	GEC	Simon Carves	Hunterston A, Tokai Mura
Atomic Power Constructions	Richardson Westgarth	International Combustion	Trawsfynydd

Table 3 Magnox power stations built by the five British consortia (before mergers).

Bradwell (six 52 MW 3,000 revs/min units) and Latina (Italy's first nuclear power station - three 70 MW 3,000 revs/min sets) used two cylinder turbines with hollow and stub HP turbine rotors and disc construction LP rotors with 102.9" (2.61 m) tip diameter exhausts. Both used dual steam supplies. Inlet conditions were:

Bradwell PS HP steam: 745 lbs/in² gauge 700°F (51.4 barg 371°C)
 LP steam: 195 lbs/in² gauge 700°F (13.4 barg 371°C)
 Latina PS HP steam: 730 lbs/in² gauge 700°F (50.3 barg 371°C)
 LP steam: 180 lbs/in² gauge 700°F (12.4 barg 371°C)

Each unit had two stages of feedheating.

The materials were generally the same as Calder Hall except that the HP turbine rotors were made from carbon 0.5 moly steel at Bradwell and 3 CrMo at Latina. This latter steel 3 CrMo was a very promising material in the 1950s, but wire wooling (the formation of steel slivers) occurred on the journal bearing surfaces of other manufacturers' machines [14]. Consequently, the use of 3 CrMo was discontinued. It was found that wire wooling was a potential risk for any turbine shaft material containing more than 2% Cr, so rotor steels with Cr contents much higher than this were generally avoided.

As station sizes increased, and concerns in the UK about the security of oil and gas supplies eased (ie conflicts in the Middle East were resolved), it became clear that fewer nuclear stations were going to be built. The consortia began to merge. In 1960, NPPC and AEI-John Thompson amalgamated to form The Nuclear Power Group (TNPG). TNPG won the orders for Dungeness A & Oldbury and shared the plant: Parsons turbines + AEI generators at Dungeness A and vice versa

at Oldbury. Parsons provided the CO₂ circulators for both stations. In 1962, GEC and APC merged to form the United Power Company (UPC) which then disbanded in 1964 when GEC stopped bidding for nuclear power projects. In 1965, English Electric, Babcock & Wilcox and Taylor Woodrow created a joint subsidiary NDC later BNDC (British Nuclear Design & Construction). Starting in 1964, advanced gas cooled reactors (AGRs) superseded Magnox designs and stations became very large (2 x 660 MW TG sets), please see later for the turbine descriptions. In 1973, with few further nuclear stations expected to be built, the remaining consortia TNPG & BNDC merged to form the National Nuclear Corporation (NNC). Parsons withdrew from the group at this point but still continued to bid for turbine-generator orders.

The Magnox stations built by each consortium from 1960 onwards are shown in table 4.

Consortium	Magnox power stations (after mergers)
TNPG including Parsons	Dungeness A, Oldbury
UPC	Berkeley
NDC/BNDC	Sizewell A, Wylfa

Table 4 Magnox power stations built by the British consortia after mergers

Dungeness A employed four 142.5 MW 1,500 revs/min turbines, figs.130 and 131. The maximum steam pressure and temperature were 535 lbs/in² gauge 736°F (36.9 barg 391°C). Bypass governing was provided to allow operation at 445 lbs/in² gauge 736°F (30.7 barg 391°C) which was one of the requirements for the reactor.

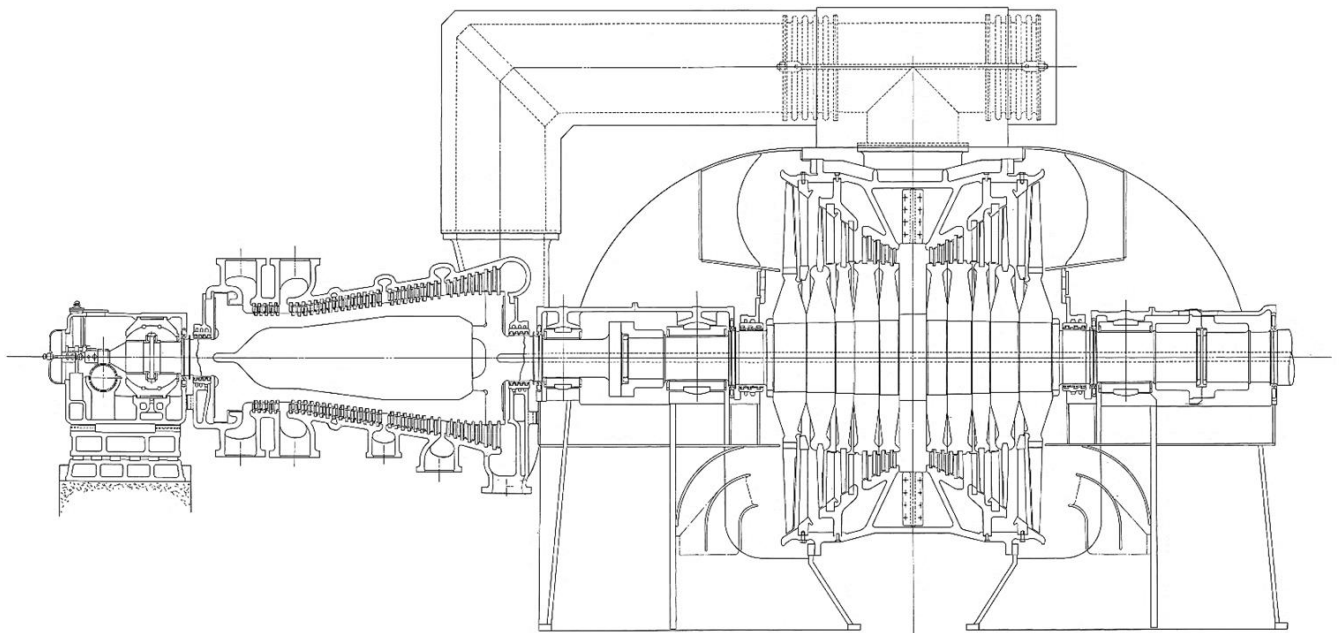

Fig.130 Dungeness A 142.5 MW 1,500 revs/min turbine 1960

These units employed last stage blades 42” (1.07 m) long with a tip diameter of 170” (4.32 m) to provide enough exhaust area with just one LP turbine. By running at half speed, these blades operated at low stress. The turbines operated satisfactorily until the plant closed in 2006.

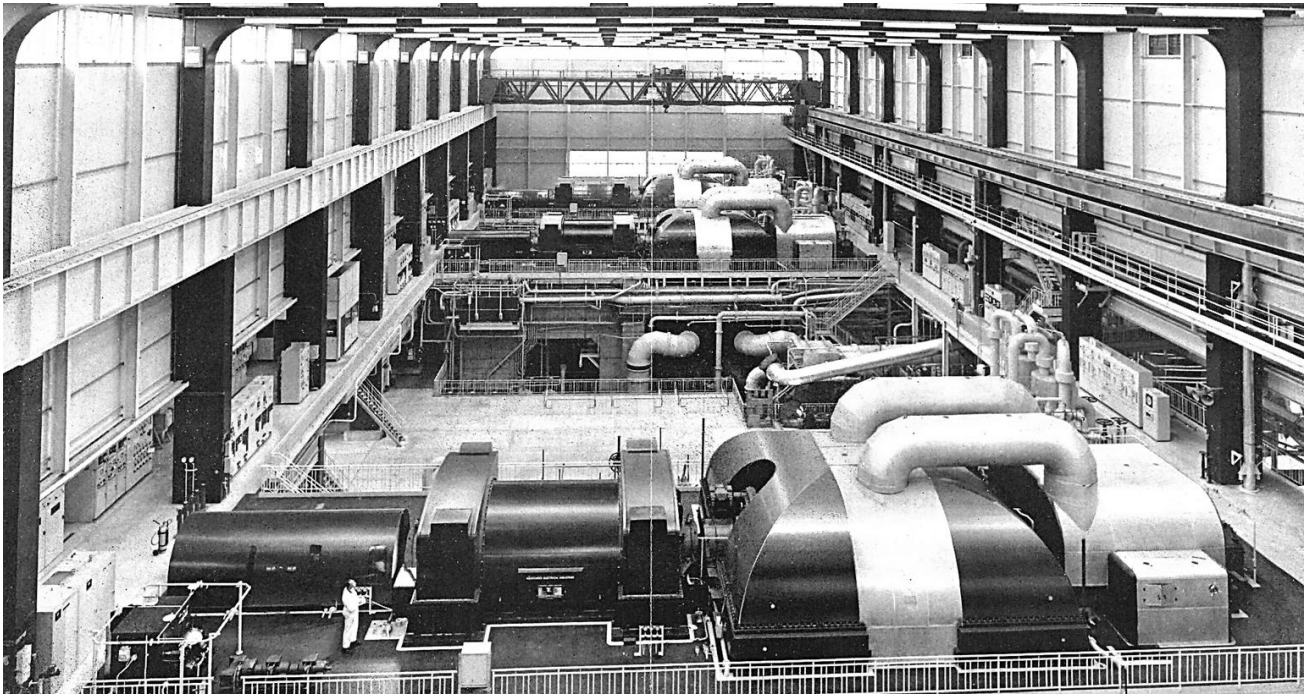

Fig.131 Three of the four units in Dungeness A turbine hall

West Thurrock 200 MW units

On the 4th May 1956, the CEA placed an order with Parsons for two 200 MW units for West Thurrock power station on the River Thames, 17 miles (27 km) east of the centre of London. They operated with HP stop valve conditions of 2,350 lbs/in² gauge 1050°F (162 barg 566°C) with reheat to 450 lbs/in² abs 1000°F (31.0 bara 538°C) and 6 stages of feedheating. The HP steam conditions became the standard values for large coal fired power plant in the UK for the next 30 years (with higher reheat conditions).

In 1956, there were no units larger than 100 MW operating at these conditions in the UK. Two stations with 100 MW non-reheat sets (not Parsons) at 1500 lbs/in² gauge 1050°F (103 barg 566°C) had been commissioned in 1955 / 56 but had not run for long. The 100 MW reheat units such as the Parsons machines for Ferrybridge B were in construction but didn't enter service until 1957. So, this commitment to 200 MW single line machines at such high conditions in 1956 represented a large step in confidence for the UK industry – both for the power utility and the manufacturers - and demonstrated the intention to develop generating units with high power outputs quickly.

Parsons decided to offer 4 exhaust flows using the new 27" (686 mm) long, 110" (2.8 m) tip diameter blades which had only just been developed for the 120 MW fleet, fig.132. This gave low leaving losses. Other manufacturers decided to offer just 3 exhaust flows with 27" blades at the 200 MW rating. At Parsons, it was considered appropriate to keep the exhaust leaving loss at the same low level as traditional 50 MW units. To achieve this with 3 flows would have meant committing to blades of around 125" tip diameter, when only 90" tip diameter blades were actually in service. It was too early for this step in blade size. It also would have required a combined IP/LP turbine rotor with sufficient creep strength to withstand the high temperatures at the inlet end of the shaft (when 1 CrMoV steel was still in its infancy) and discs made from LP turbine rotor steels to carry LP blades taller than ever before at the other end. Parsons decided that the design they offered was a large enough step in technology without incurring risks to shaft & blade integrity. Both efficiency & technical risk favoured 4 flows.

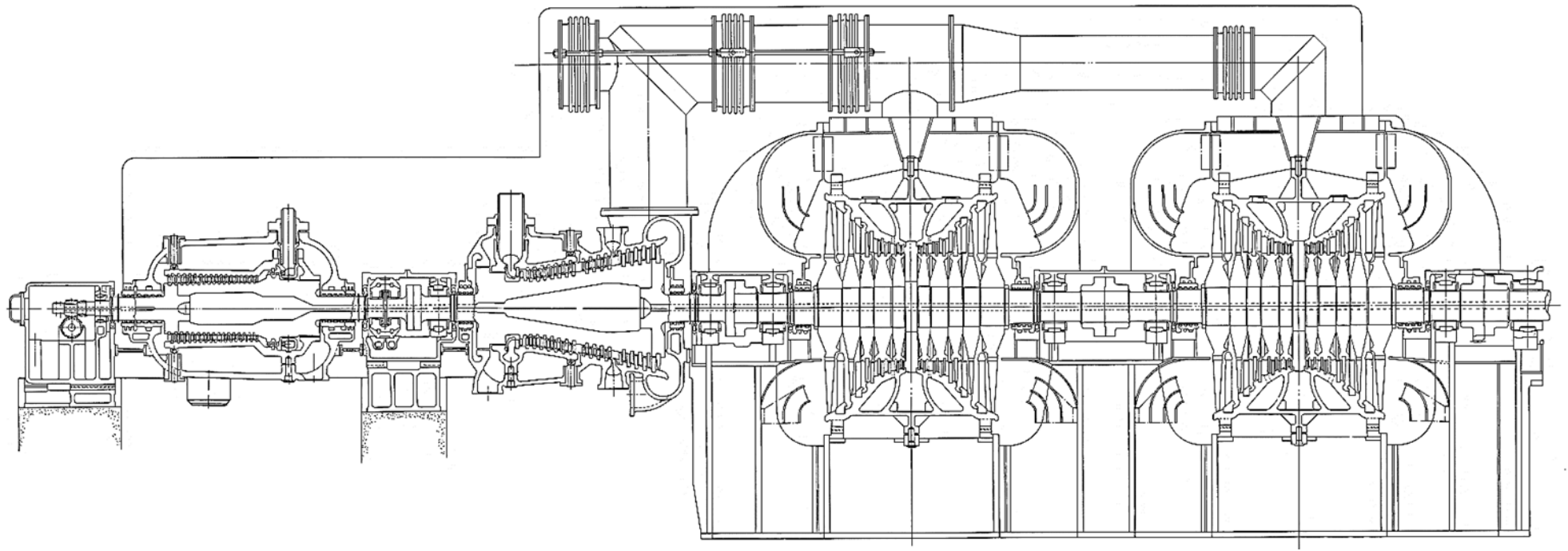

Fig.132 West Thurrock 200 MW 3,000 revs/min turbine 1956

The West Thurrock design was 1.7 times more powerful, it operated at pressures 1.6 times higher and temperatures which reduced the strength of the rotor & casing steels by 30% compared with the largest single line units designed by Parsons so far (the 120 MW sets engineered just 2 years earlier). Today, a 200 MW turbine with four exhaust flows might seem conservative, but in 1956, this represented a substantial step in technology.

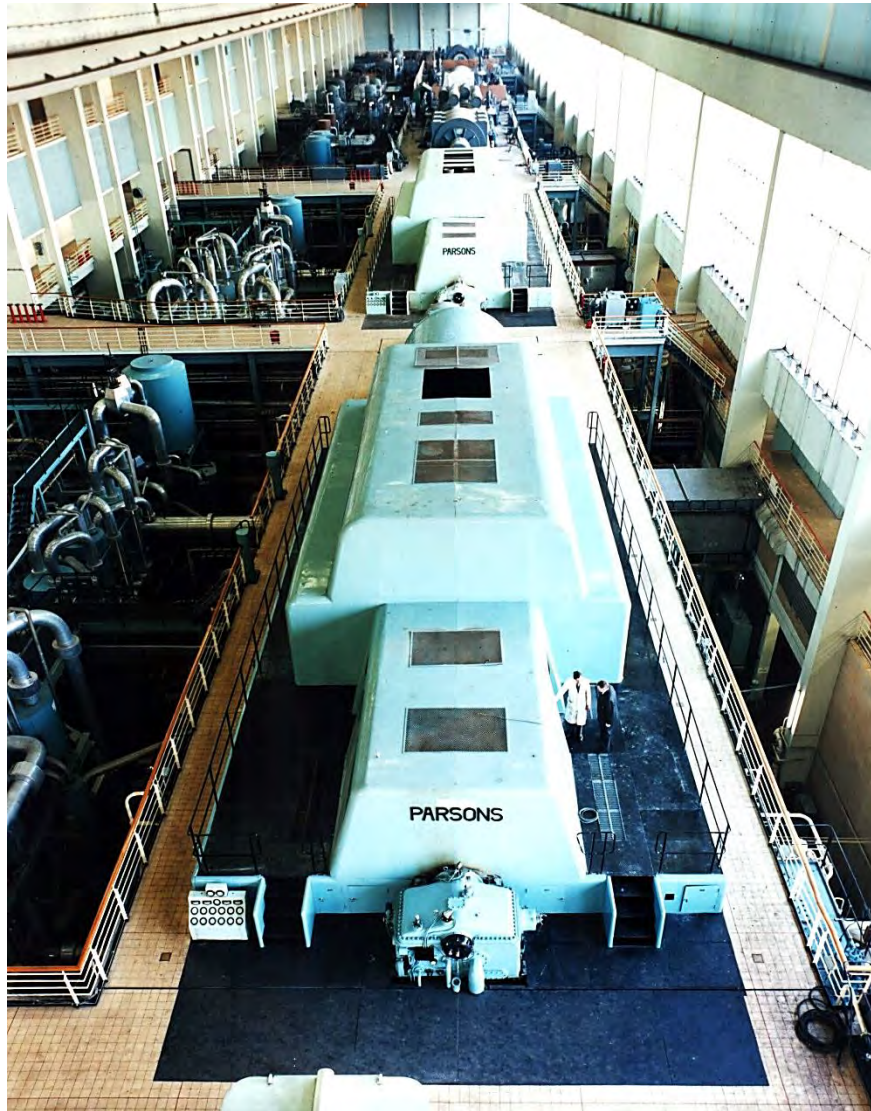

Fig.133 West Thurrock turbine hall

West Thurrock was the largest power station in London at the time. To ensure the noise levels were satisfactory both inside and outside the turbine building, acoustic covers were placed over the machines. These enveloped the entire HP-IP-LP1-LP2 turbine line including the steam chests. The noise level adjacent to one of the Parsons units was 87 dBA.

This was the first power station with Parsons machines to have all of the boiler and turbine-generator controls for each unit located in one place rather than distributed around the turbine hall and adjacent rooms, fig.134. In addition, Unit 2 was the first Parsons turbine-generator to have an automatic start-up system installed taking advantage of the new digital computers.

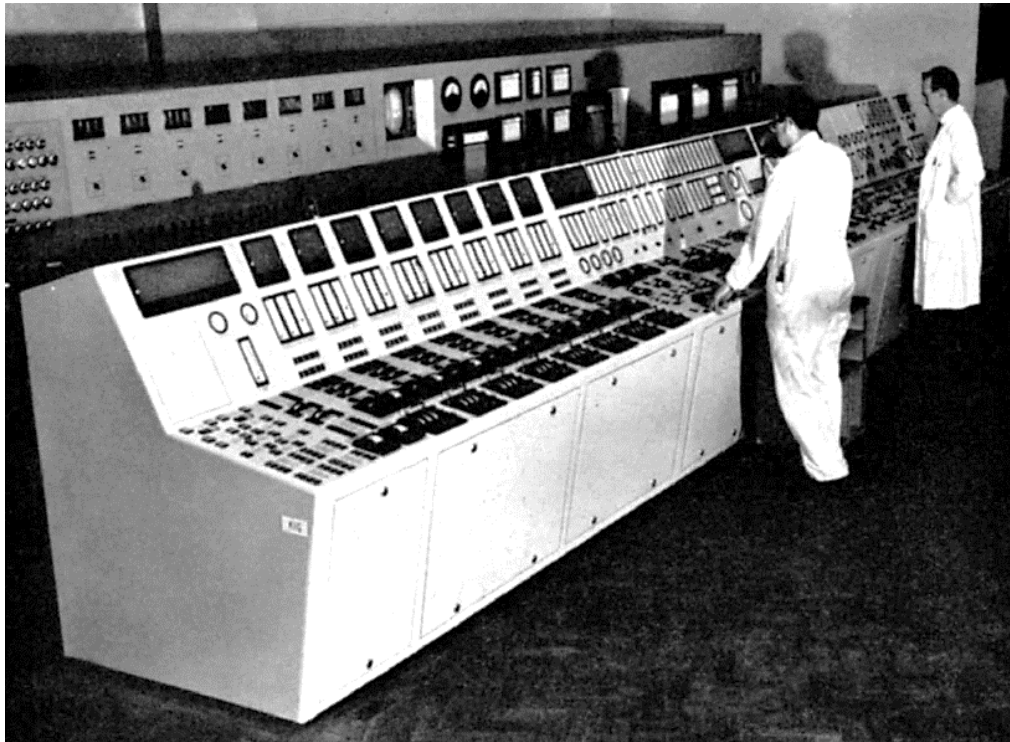

Fig.134 West Thurrock control room

The HP turbine, fig.135, was double cased with the highest feedheat extraction placed at the inlet end to promote cooling of the inner casing similar to the 100 & 120 MW units, but separate nozzle chest castings were used to make the turbine effectively triple cased in the inlet region. The hollow and stub shaft and the casings were made from 1 CrMoV steel. A Curtis stage was used at inlet to reduce the conditions to 96.6 bara 495°C primarily to ensure that the bolted joint of the inner casing would be successful. The reaction blades were IFR construction and made from 12 CrMoV steel (stronger than the 12 CrMo used in the 120 MW units).

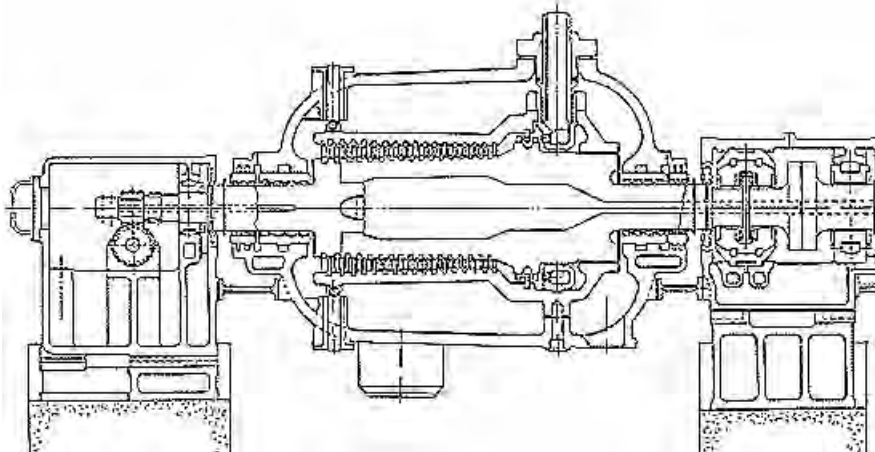

Fig.135 West Thurrock HP turbine

The Curtis stage produced 18.4 MW at full load (ie 9% of unit output) at an efficiency of 73.3%. This sacrificed over 15% in efficiency (ie 4 MW) compared with reaction stages solely to reduce the pressure differential acting on the casing joint. This was the last time that a Curtis stage would be used by Parsons in a 50 Hz turbine of 200 MW or more.

West Thurrock (together with the RL Hearn 200 MW units, see next chapter) were the first Parsons turbines to use cooling steam to reduce the IP turbine rotor temperature. A small amount of HP turbine exhaust steam at 651°F (344°C) was injected through holes drilled in the inlet flow deflector, fig.136, to emerge adjacent to the root fixings of the Rateau stage moving blades in the IP inlet. Here the cool steam mixed with normal IP inlet steam at 1000°F (538°C) to produce a mixture temperature of 850°F (454°C) in a local zone under the flow guide. This steam flow cooled the impulse stage root fixings and then passed through the dummy piston seals to the no.3 gland. This meant that the entire dummy piston and inlet zone of the rotor was surrounded by relatively cool steam at 850°F (454°C). In the centre of the shaft, heat was drawn away by conduction to the no.3 bearing, which acted as a heat sink, so together with the cooled shaft surface, the temperature at the rotor bore was reduced to around 860°F (460°C). This lowered the creep strain rate in both the rotor body and the first stage root fixings substantially. It also improved the resistance to thermal fatigue on the shaft surface. Since finite element software didn't exist in 1956, shaft temperatures were predicted using an 'electrolytic tank' ie an electrical representation of the rotor applying voltages to simulate temperatures at the boundaries of the model via resistances chosen to represent the heat transfer coefficients, then measuring voltages within the model to determine the expected temperatures. The predicted temperatures for the inlet zone of the West Thurrock IP shaft with and without cooling steam are shown in figs.137a and b. These predictions proved to be reasonably accurate when checked with modern methods. Cooling steam was applied to nearly all subsequent Parsons single flow IP turbines using this arrangement.

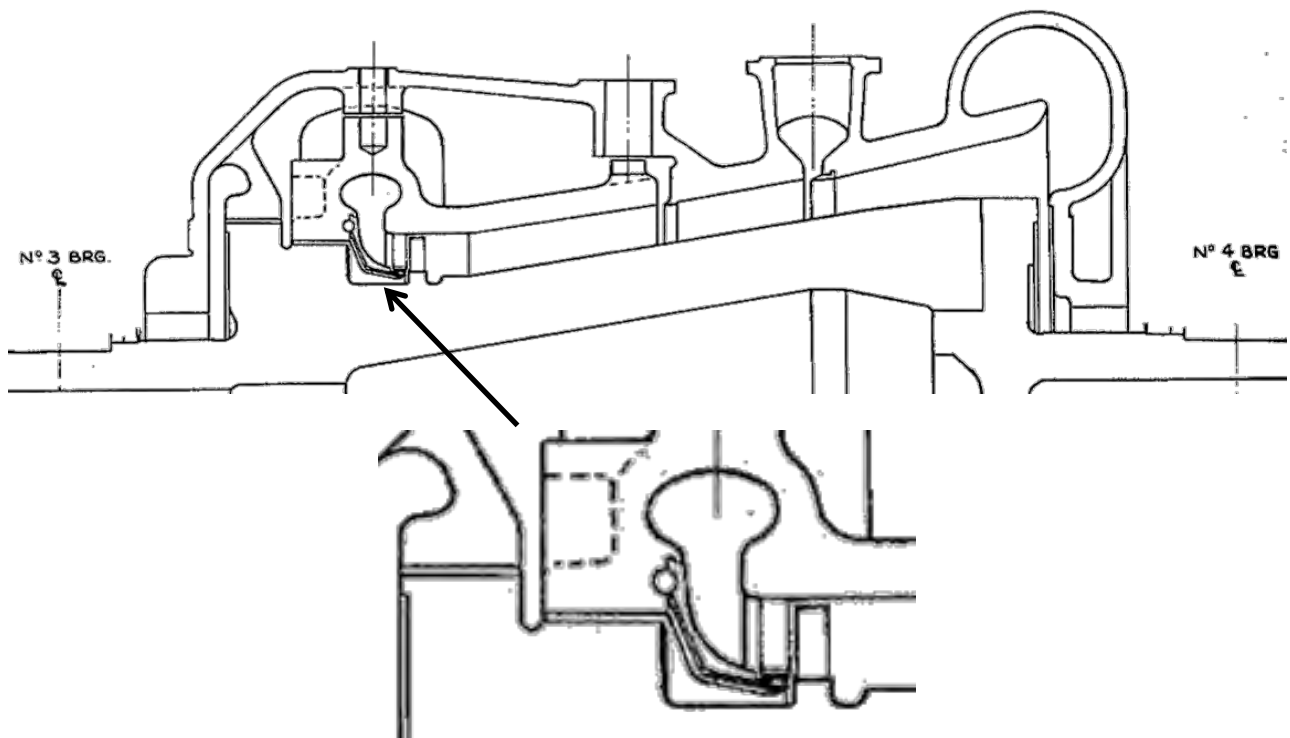
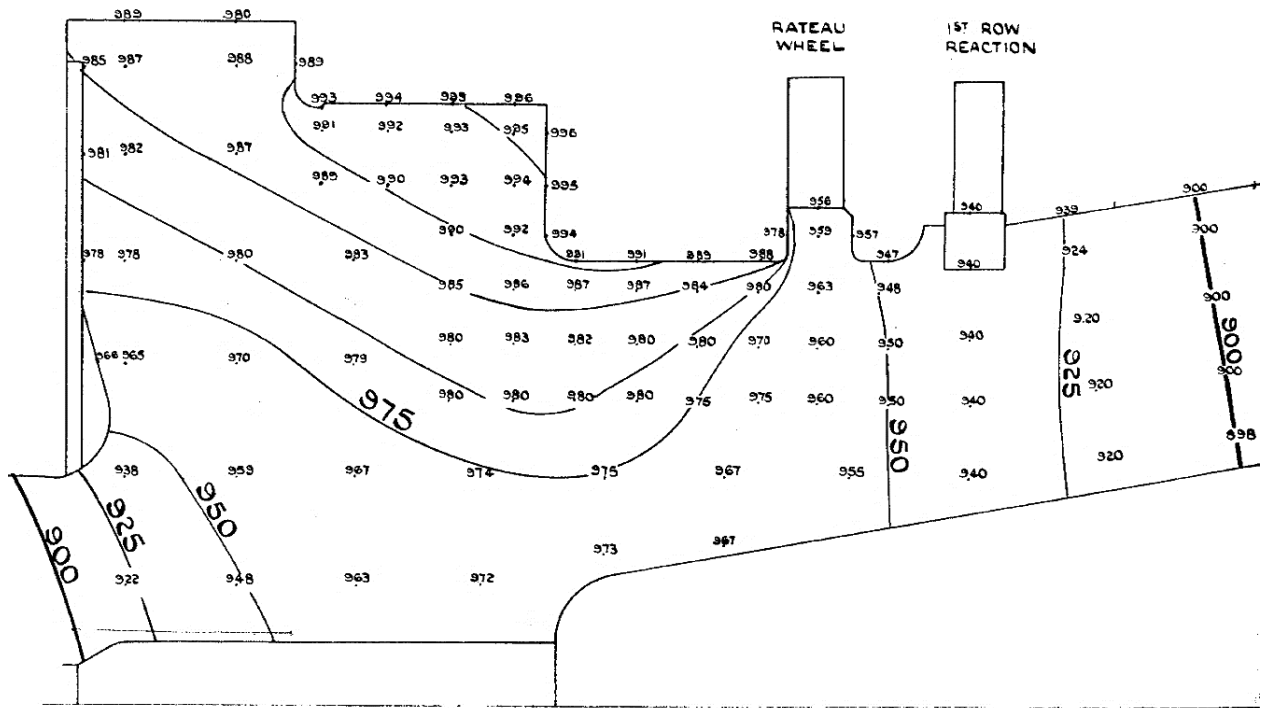
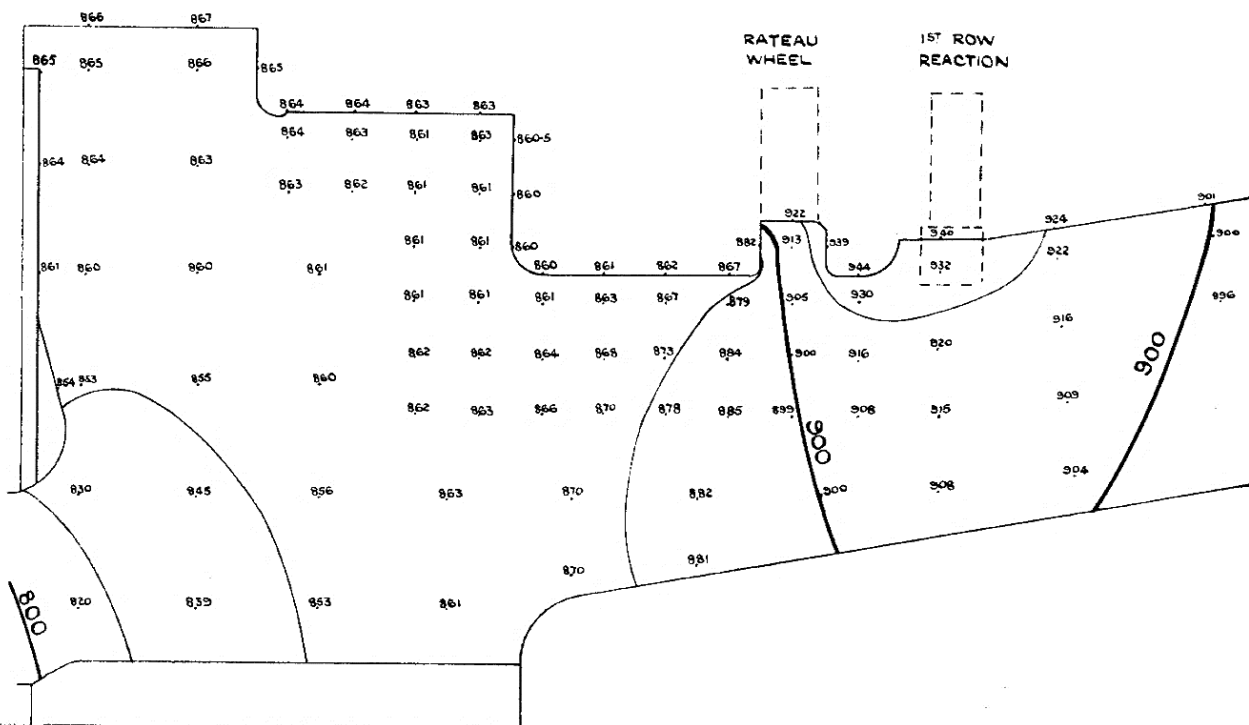

Fig.136 Cross-section through the West Thurrock IP turbine casings showing the cooling steam passageways. HP turbine exhaust steam was fed into a circular passageway, machined where the inlet flow deflector attached to the inner casing, to distribute the steam around the casing circumference and then the steam passed through 8 small passageways to the tip of the flow deflector emerging adjacent to the Rateau stage root fixings.

Since all of the injected cooling steam passed to the dummy piston, this did not benefit the bladed section of the casing, so a Rateau stage was provided to reduce the steam conditions to 25.1 bara 512°C and so allow the downstream reaction stages, rotor and casing sections to run cooler also.



a Without cooling steam



b With cooling steam

Fig.137 Predicted temperatures in the inlet region of the West Thurrock IP turbine shaft from the original 1950s electrolytic tank model, values in °F

The LP turbines were essentially similar to those used in the Skelton Grange B 120 MW sets. The key difference was in the outer casing. Since West Thurrock had two LP turbines, the bottom half outer casings were combined into one structure. This was adopted on machines with multiple LP turbines to eliminate the effect of foundation settling on the alignment and to ensure smooth running of the shaft train. It became a standard feature until 1967.

RL Hearn GS 200 MW 60 Hz units

An order for four 200 MW units for RL Hearn GS in Toronto was received at the same time as West Thurrock. The design of the turbines was completely different, however, fig.138.

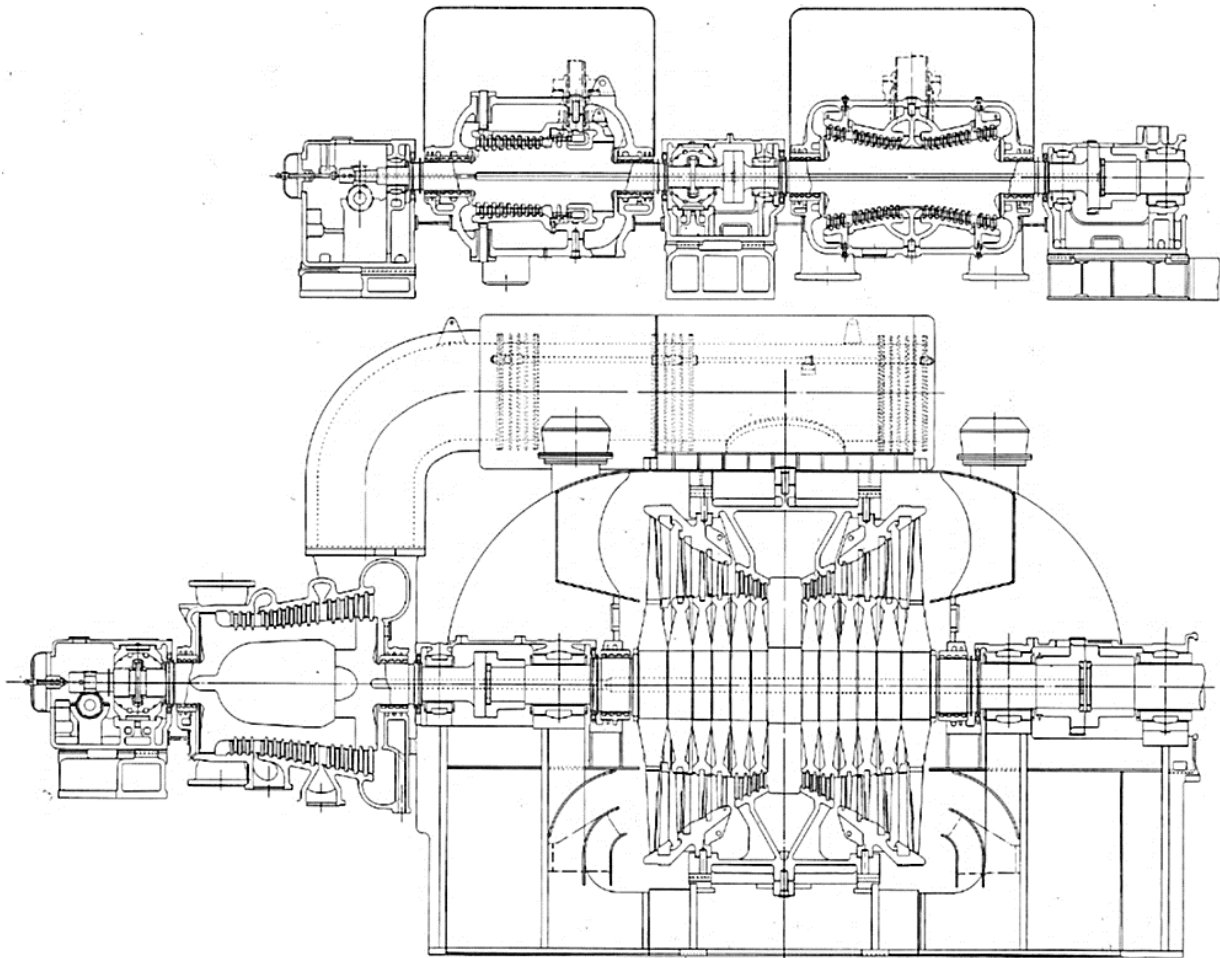

Fig.138 RL Hearn GS 200 MW cross-compound turbine with the HP & IP1 turbines running at 3,600 revs/min on the A line, *top*, and the IP2 and LP turbines running at 1,800 revs/min on the B line, *bottom* 1956

The specified rating of 200 MW at 60 Hz was dynamically equivalent to 288 MW at 50 Hz. The rating of these machines was therefore effectively 1.44 times higher than West Thurrock. With this in mind, it was decided to use a cross-compound arrangement for RL Hearn with each turbine line producing 100 MW at 60 Hz. The factors limiting the rating of each line were the generator rotors and the LP turbine last stage blades.

The steam conditions were 1800 lbs/in² gauge 1000°F (124.1 barg 538°C) at the HP stop valve and 400 lbs/in² abs 1000°F (27.2 bara 538°C) at the IP1 inlet. There were 6 stages of feedheating. The HP and IP1 turbines on the A line ran at 3,600 revs/min, fig.139. This reduced their physical size and so lowered thermal stresses. The high speed also reduced the stage count. The HP turbine had a Curtis stage with separate nozzle chests, similar to West Thurrock, but was nozzle governed. The IP1 turbine was double flow. It used HP exhaust steam to cool the IP1 rotor injecting it directly beneath the inlet flow deflector without any mixing with hot steam. This form of cooling was subsequently employed on all Parsons double flow IP turbines. The IP1 turbine employed only reaction blading and was double cased to allow cooling of the inner casing. All HP and IP reaction blades were IFR construction made using 12 CrMo steel.

The steam conditions at the inlet of the IP2 turbine were 123 lbs/in² abs 705°F (8.5 bara 374°C). The B line ran at 1,800 revs/min so that only one (large) LP turbine could be used, fig.140. The last stage blades were 37" (939.8 mm) long with a tip diameter of 150" (3.81 m), fig 141. An IP2 turbine was used, with a carbon 0.5 moly rotor body and carbon steel casing; otherwise the steam temperature 374°C could have caused temper embrittlement of the LP turbine rotor steels.

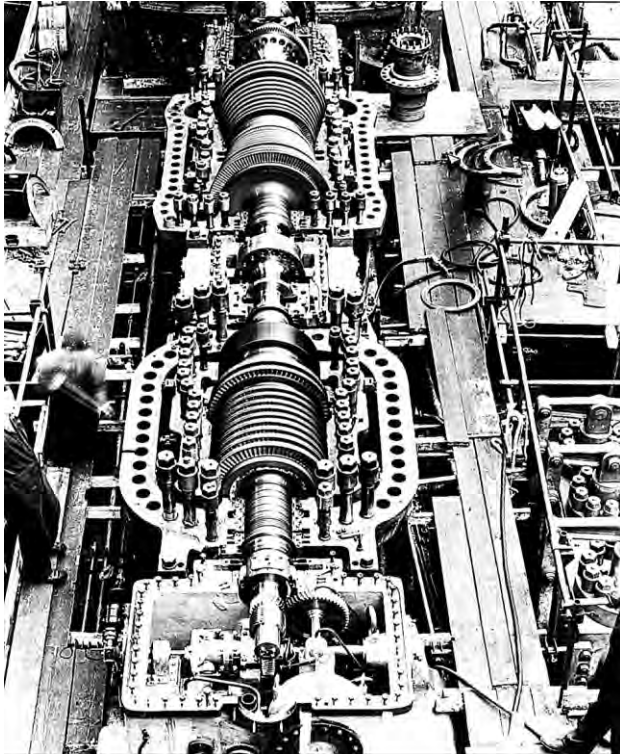

Fig.139 RL Hearn 200 MW A line

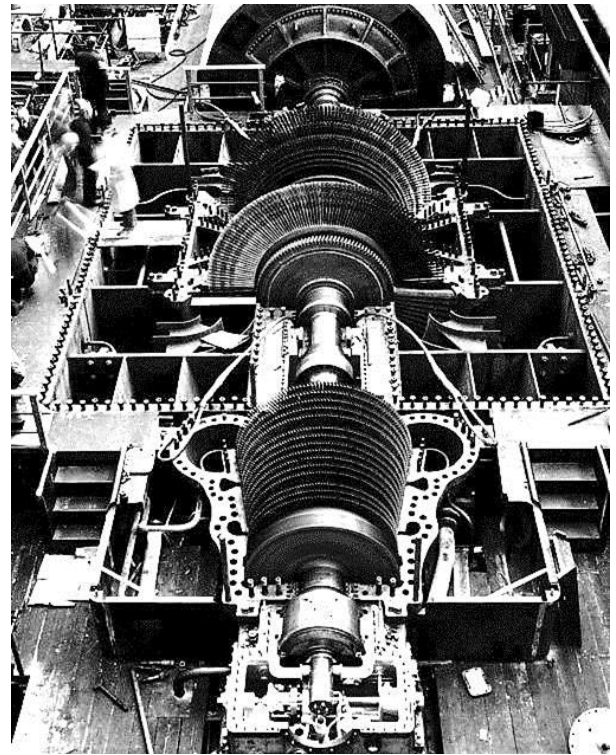

Fig.140 RL Hearn 200 MW B line

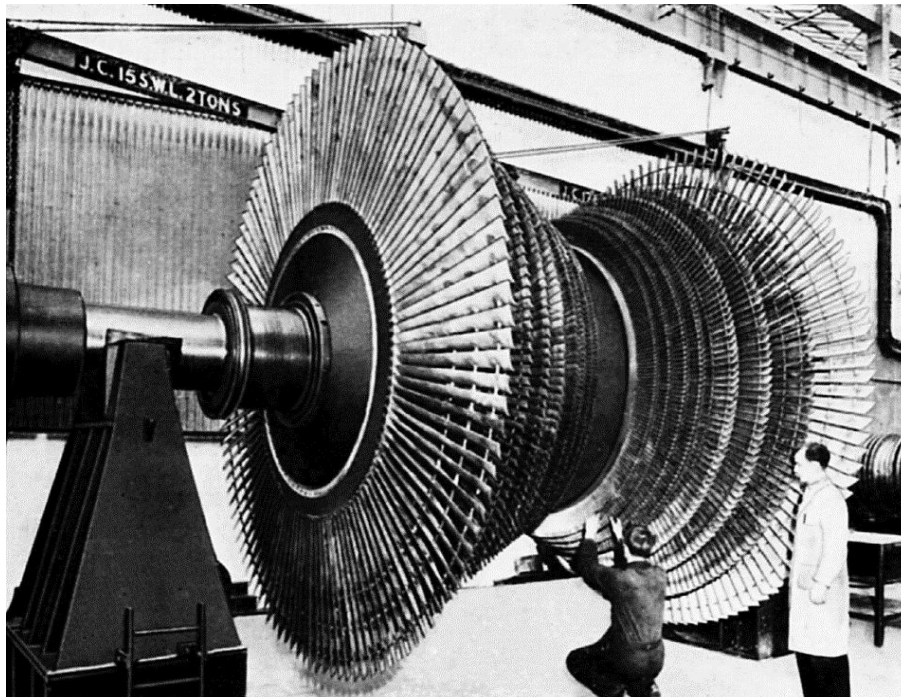

Fig.141 RL Hearn 200 MW LP turbine rotor

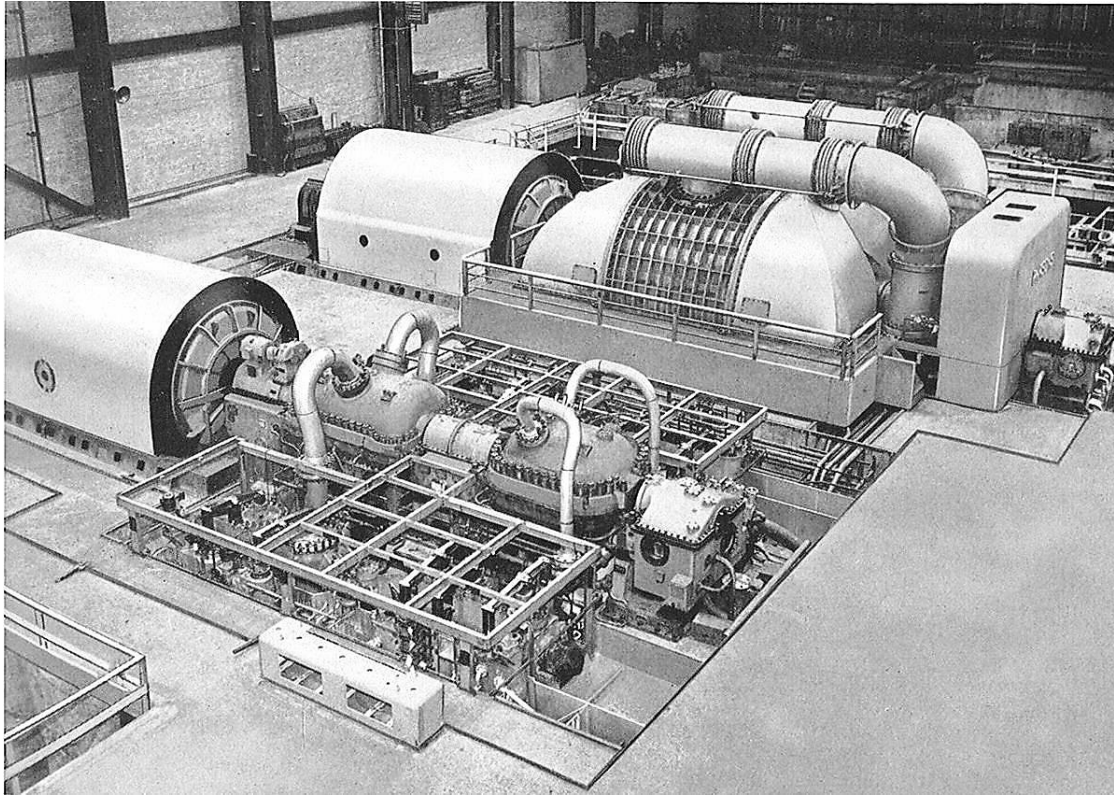

Fig.142 An RL Hearn unit during installation at site

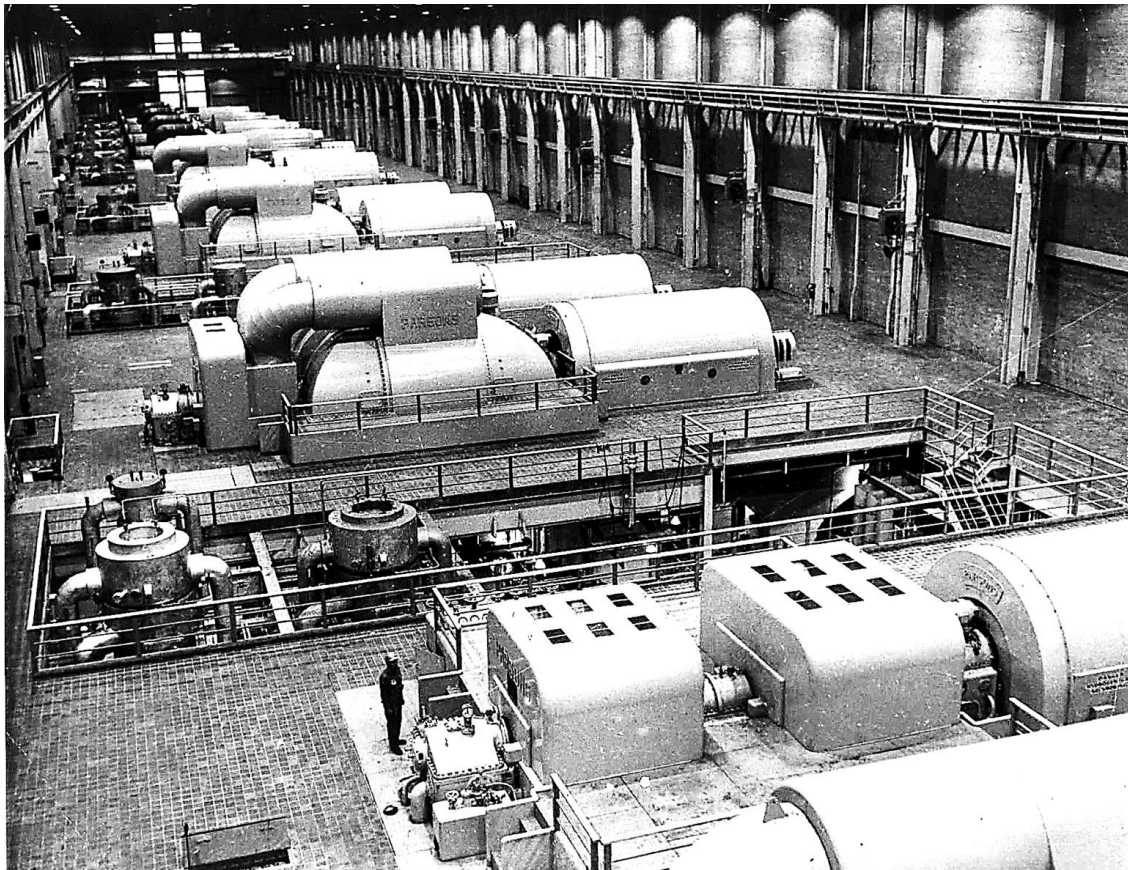

Fig.143 RL Hearn GS turbine hall with four Parsons 200 MW units in the foreground and four 100 MW sets in the background. At the time, this was Canada's largest thermal power station.

Lakeview GS 300 MW 60 Hz Units 1 & 2

In 1957, Ontario Hydro ordered the first two units for Lakeview Generating Station in Mississauga, 15 miles from the centre of Toronto. Eventually, there would be 8 x 300 MW sets installed in the station:

Units 1 & 2 were Parsons cross-compound designs

Units 3 to 6 were AEI single-line units with Baumann exhausts

Units 7 & 8 were Parsons single line units

Unit 1 first generated power on 30th October 1961. The station was officially opened by Premier John Roberts on the 20th June 1962. Once completed, it was the largest thermal plant in Canada until Nanticoke was built, see later. The plant operated until 30th April 2005.

The machine rating 300 MW at 60 Hz was dynamically equivalent to a 432 MW unit at 50 Hz, so this represented another large step in technology.

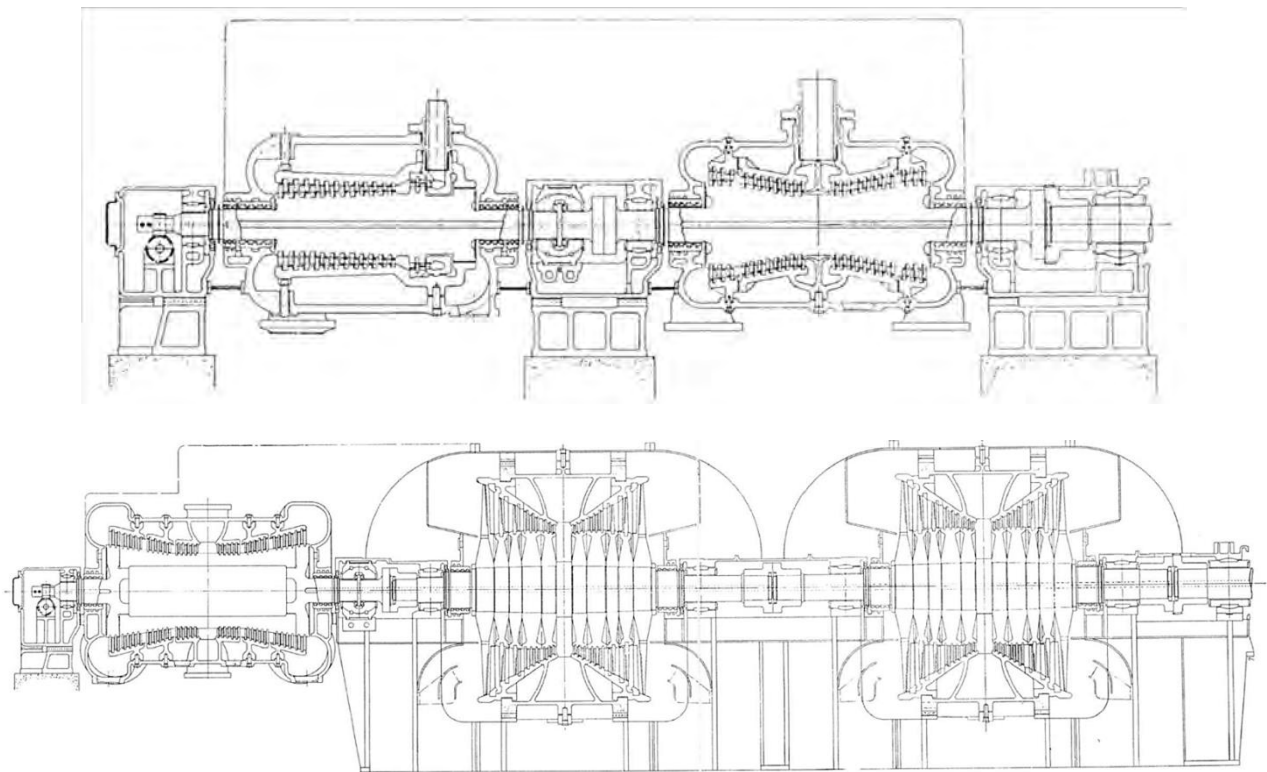

Fig.144 Lakeview GS 300 MW cross-compound turbine with the HP & IP1 turbines running at 3,600 revs/min on the A line, *top*, and the IP2, LP1 and LP2 turbines running at 1,800 revs/min on the B line, *bottom* 1957

The steam conditions were 2350 lbs/in² gauge 1000°F (162 barg 538°C) with reheat to 430 lbs/in² abs 1000°F (29.7 bara 538°C). There were 7 stages of feedheating. Ordered only one year after the RL Hearn 200 MW sets, the first two Lakeview turbines were essentially larger versions of the Hearn machines retaining the cross-compound layout, fig.144. At the time Unit 1 was commissioned, the design was 50% larger than any other turbine-generator operating anywhere in the British Commonwealth including the UK.

The HP turbine used a nozzle governed Curtis stage which produced 27.7 MW at an efficiency of just 73.7%. This was the last large Parsons machine to use a Curtis control stage. All future machines above 100 MW would use either a Rateau stage (for nozzle governing) or all-reaction blading (for throttle governing or sliding pressure control).

Due to the higher power output, the IP2 turbine was double flow and two LP turbines rather than one were used. The last stage LP blades were 34" (863 mm) long with a 140" (3.56 m) tip diameter to give a total flow area of 314.5 ft² (29.2 m²) compared with the RL Hearn blades which were 37" (939.8 mm) long with a 150" (3.81 m) tip diameter to give a total flow area of 182.4 ft² (17.0 m²). Lakeview therefore had 72% more exhaust area for units 50% larger than RL Hearn which reduced leaving losses.

The IP2 turbine was almost literally a double flow version of the RL Hearn IP2 with the same no. of stages per flow (15), the same rotor diameters (inlet 50" [1.27 m] exhaust 60" [1.52 m]) and the same steam conditions at inlet & outlet approximately. A twin shell IP2 casing with separate blade rings was used to help control in-service deflections and allow simpler castings.

The steam chests were larger versions of the Skelton Grange B designs and the unit used reheat release valves as previously described.

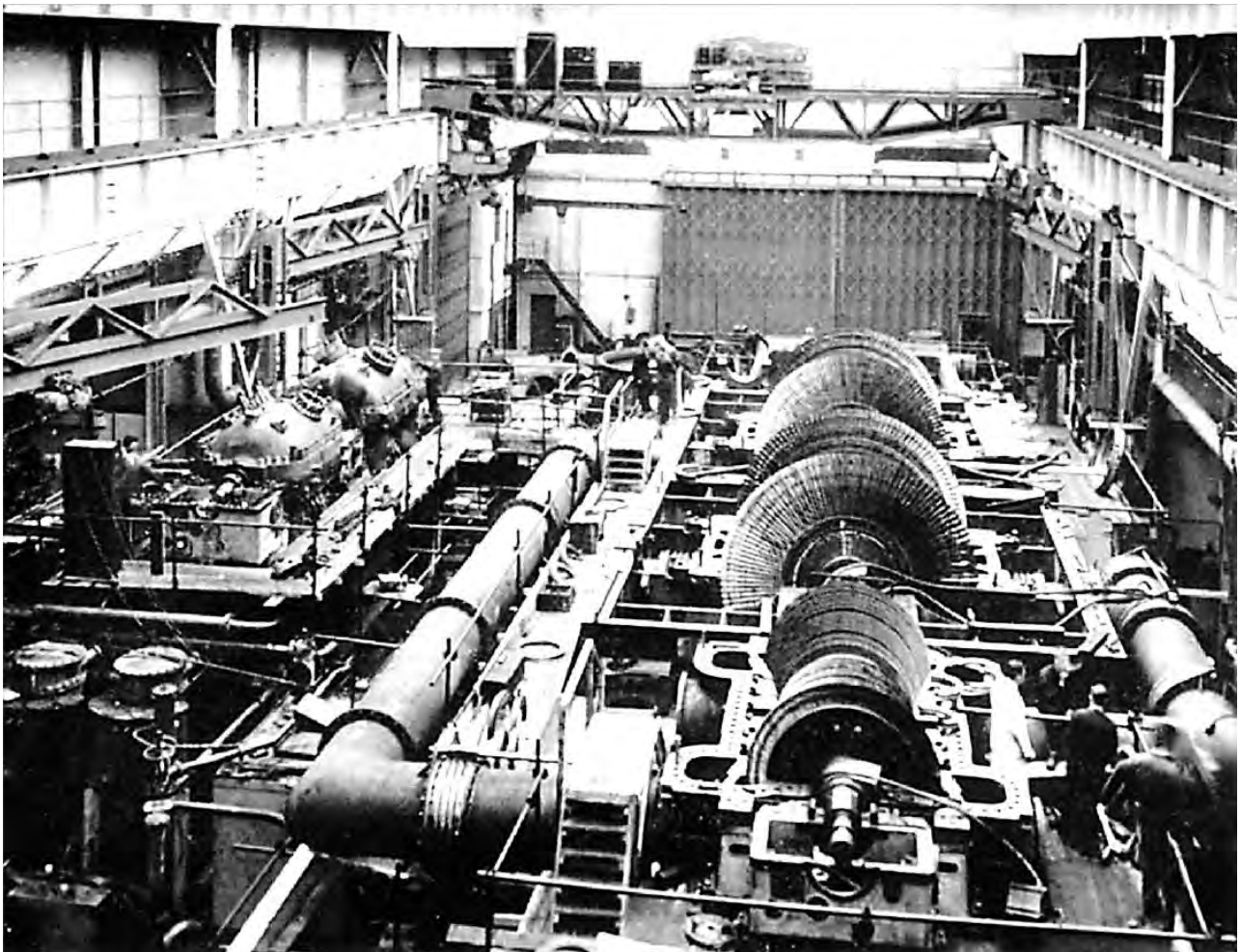

Fig.145 Lakeview Unit 1 in Heaton Works in 1960. Once machines became too large to test at full power in the Works, it became standard practice to run the turbine and generator up to full speed, usually separately. Here we can see pipework being installed to 'steam the machine'.
In-Works steaming of turbines was discontinued during the late 1970s.



Fig.146 Lakeview Unit 1 installed at the station – A line on the *right* and B line on the *left*

Thorpe Marsh Unit 1 550 MW 3,000 revs/min cross-compound turbine

In 1958, the CEGB placed an order with Parsons to build a 550 MW 50 Hz unit at Thorpe Marsh near Doncaster. At the time, TG sets up to 275 MW were being manufactured by others in the UK, but only units up to 120 MW had entered service, and there was very little operating experience even on these. It was necessary to show some conservatism in the new design. As with Lakeview, the principal factors which limited the machine rating were the generator rotor design and the length of the last stage blades. It was decided that the unit should be cross-compound with each line driving a 275 MW generator at 3,000 revs/min. New larger LP last stage blades had been developed which were 30" (762 mm) long with a tip diameter of 120" (3.05 m). To optimise the leaving losses, it was agreed with the CEGB that 8 exhaust flows ie four LP turbines should be employed. This led to Thorpe Marsh being the most complex turbine Parsons ever built, but at the time, it was by the far the largest TG set in the World.

The steam conditions were 2300 lbs/in² gauge 1050°F (158.6 barg 566°C) at the HP inlet and 550 lbs/in² abs 1050°F (37.9 bara 566°C) at the IP1 inlet. There were 7 stages of feedheating.

A cross-section through the turbine is shown in fig.147.

The unit operated until March 1994 and for most of its life gave good service, but there were some important lessons learned, see below.

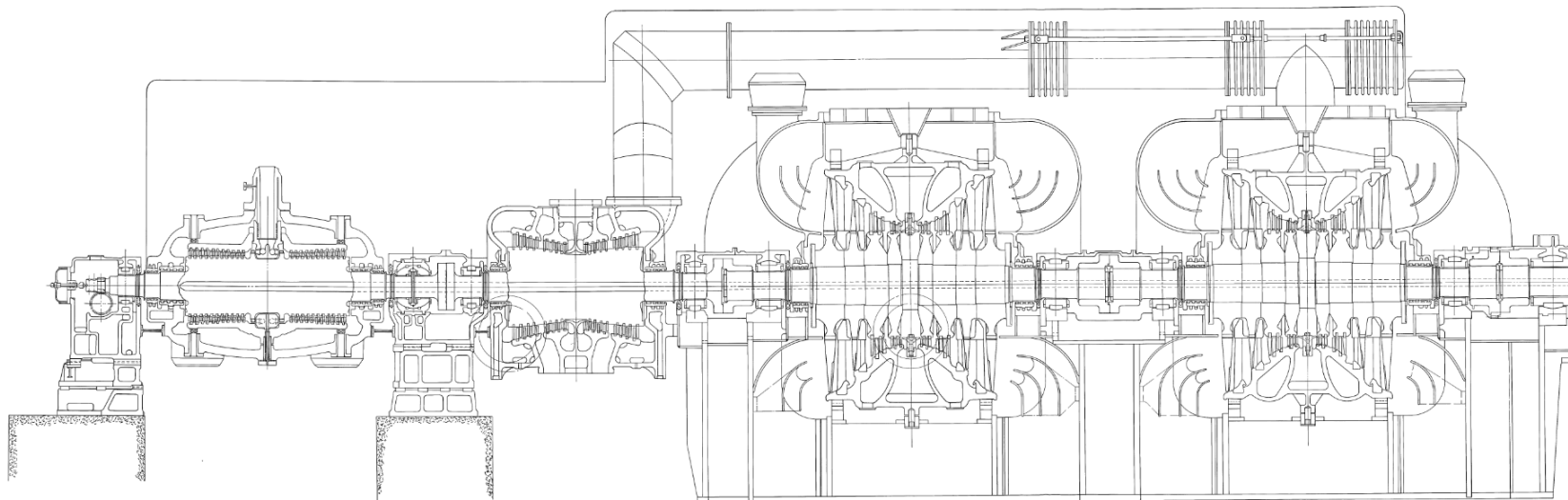

a The A line comprising the HP turbine, an IP2 turbine and two LP turbines

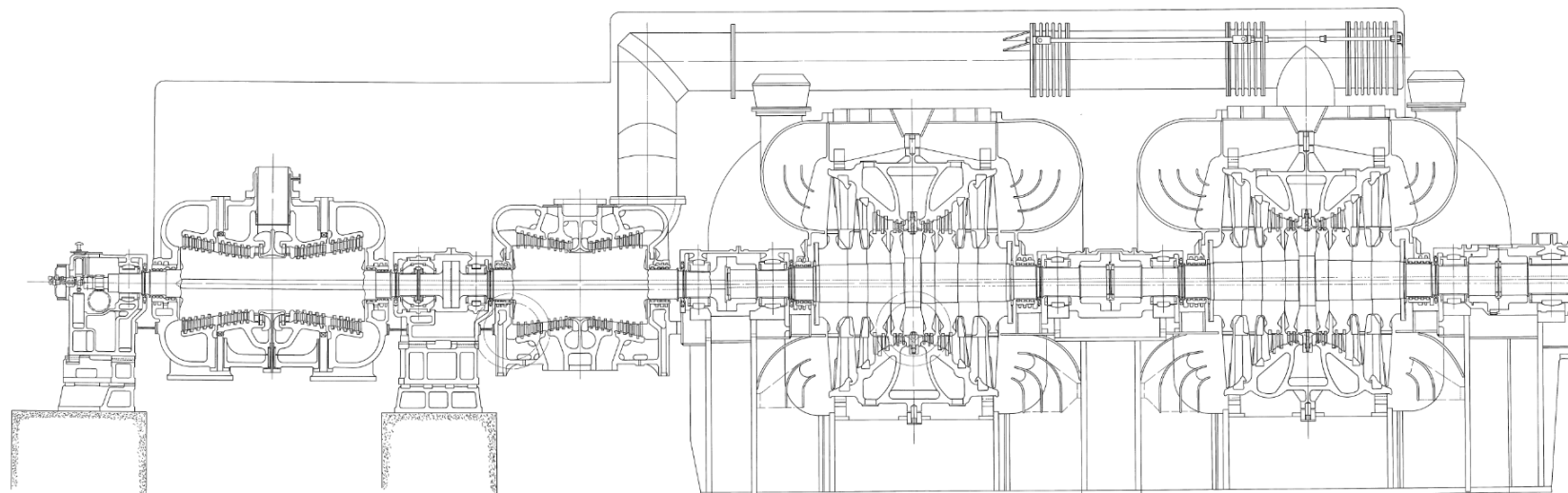

b The B line comprising the IP1 turbine, an IP2 turbine and two LP turbines

Fig.147 Thorpe Marsh 550 MW 3,000 revs/min turbine 1958

The HP turbine was double flow with a Rateau stage at inlet, throttle governed, to reduce the steam conditions to 1600 lbs/in² abs 962°F (110.3 bara 517°C). The Curtis stage employed in previous machines was now eliminated, but the stage loading on the Rateau stage remained high ($U/C_0 = 0.33$) to drop the temperature. The stage loading was lower than the optimum value for a two row Curtis wheel ($U/C_0 = 0.24$) but higher than the optimum for a Rateau stage ($U/C_0 = 0.48$) and so will have sacrificed some efficiency. [Please note: 'high stage loading' implies a high steam velocity C_0 and hence a low value of U/C_0]. To maintain reasonable blade heights, the base diameter of the reaction stages was 34" (863 mm). By keeping the diameter down, this increased the stage count. The HP turbine casing was a twin shell design with separate nozzle chests.

For the first time on a Parsons machine, the HP turbine rotor was cooled. Since there was no source of cool steam at a higher pressure which could be injected, live steam was routed through a tubular heat exchanger arranged in the top half of the outer casing, fig.148, to reduce its temperature sufficiently. The steam entered underneath the nozzle chests and so cooled the inlet section of the shaft and the first moving blade root fixings in each flow.

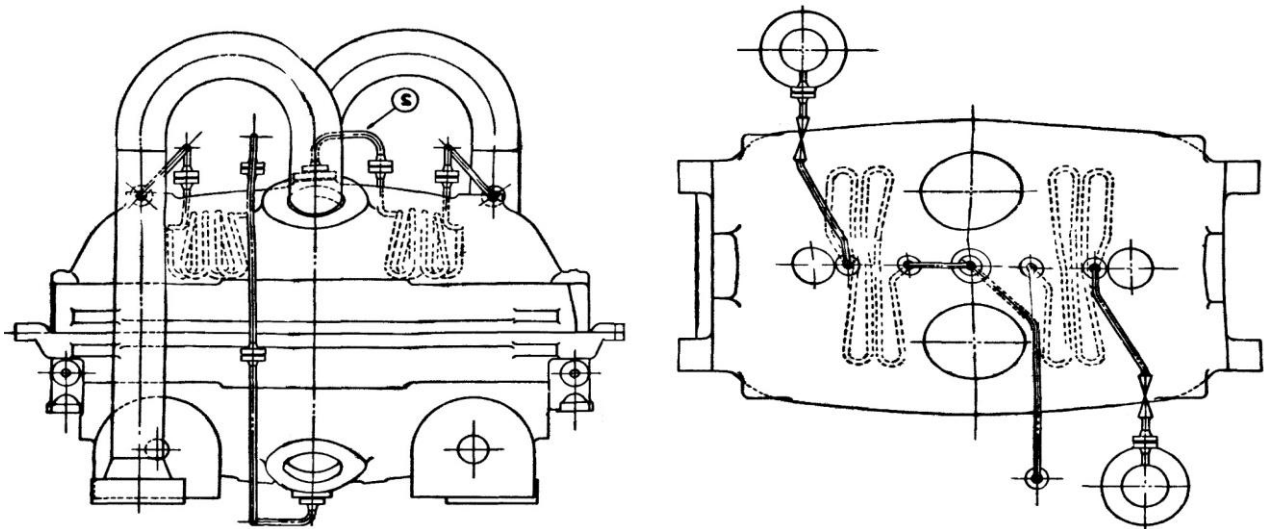

Fig.148 Thorpe Marsh HP turbine casing showing the rotor cooling steam pipes which acted as heat exchangers

In practice, the heat exchanger coils cracked in service. Even though the pipes were mounted in the top half of the casing and the exhaust pipes were taken from the bottom half, sufficient turbulent, high speed steam reached the pipes to damage them. Following this, the heat exchangers were removed and the holes which had been used to pass the cool steam inwards were left open to allow a small amount of steam to flow outwards. This ventilated the space beneath the nozzle chests and carried away heat produced by windage on the shaft surface.

During the 1980s, a new reaction blade aerofoil was developed which replaced the 600 series profile. Since this gave a useful performance gain and there was the opportunity to optimise the stage loading of the Rateau stage, the CEGB ordered a new inner casing and rotor to upgrade the HP turbine, fig.149. This was the first application of the R series blade. The 'ventilation' arrangement in the inlet region was retained. Performance tests showed that the upgrade improved the heat rate of the unit by 1.43% relative to its aged condition (1.1% compared with its original acceptance test). A saving in heat rate of 1.43% corresponded with an improvement in HP turbine efficiency of around 9%.

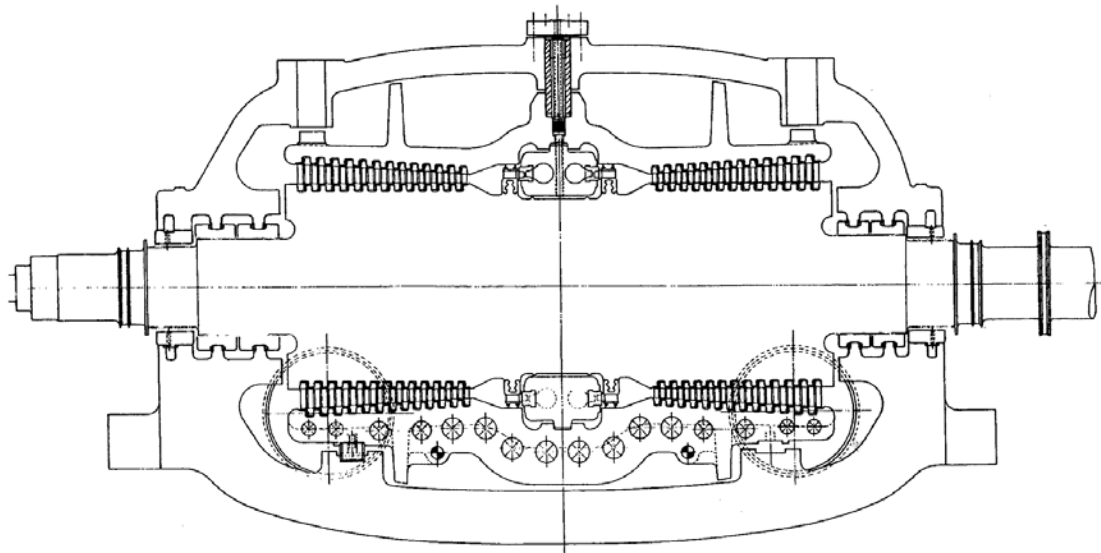

Fig.149 New rotor & inner casing installed in the original outer casing to upgrade the performance of the Thorpe Marsh HP turbine, designed in the late 1980s. The top half of the drawing shows a section through the vertical plane and the bottom half shows the horizontal cross-section.

The IP1 turbine was mounted on the B line and was conventional in construction with a 1 CrMoV monobloc rotor and double casing. The bladepath included a Rateau stage in each flow again to reduce the steam temperature followed by reaction blading. The IP1 rotor was cooled by injecting HP turbine exhaust steam in the same way as the RL Hearn 200 MW IP1 turbine. No heat exchangers were needed in this case.

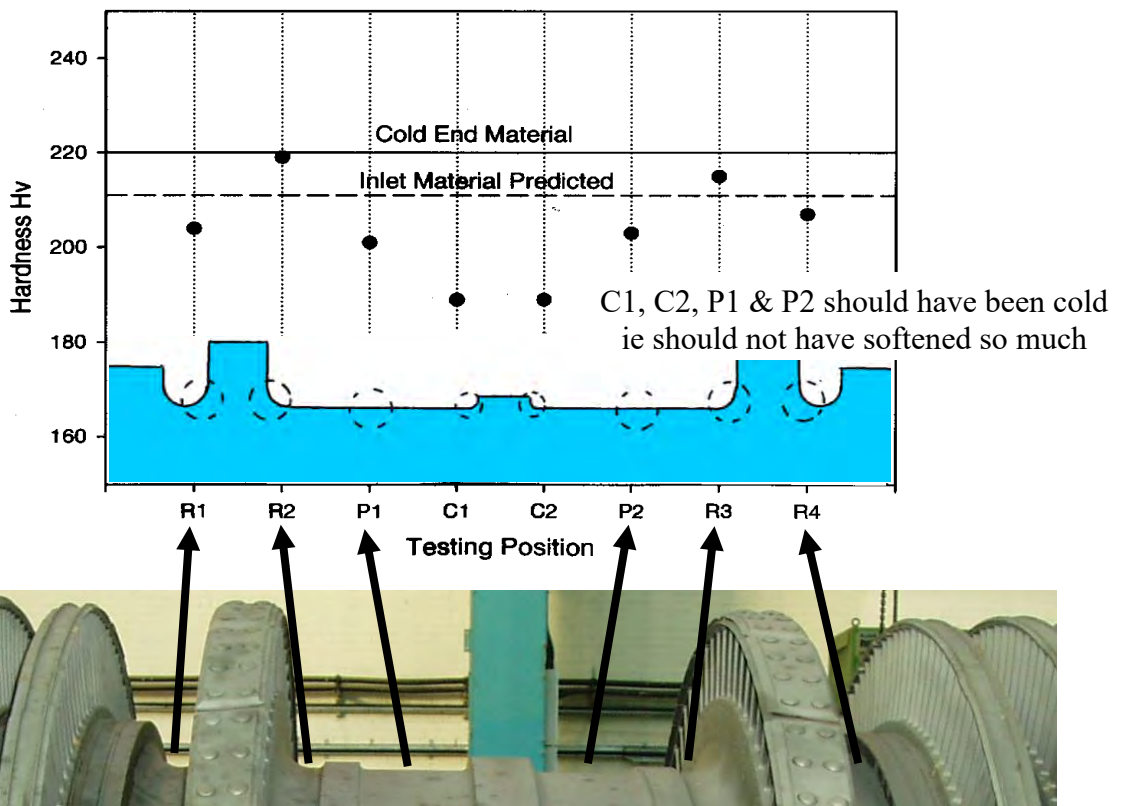

Fig.150 Hardness readings from the inlet region of Thorpe Marsh IP1 turbine rotor after the cooling steam supply was isolated

The IP1 cooling steam worked perfectly until someone at the station inadvertently blanked off the supply. With no cooling steam in or ventilating steam out, the inlet section of the rotor overheated due to windage heating. Hardness readings, fig.150, showed that the surface temperature reached 600°C in service (despite the highest steam temperature being 566°C), which matched the temperature predicted by Dr Frank Dollin, Parsons Chief Design Engineer, in his 1963 paper [15]. This caused accelerated ageing of the steel ie there was a potential loss of creep strength, tensile strength and fracture toughness. In addition, the fir tree root pockets of the Rateau moving blades overheated and this caused extensive cracking at the root fixing serrations. The degradation was sufficient to retire the shaft.

The inlet conditions to the two double flow IP2 turbines were 150 lbs/in² abs 713°F (10.3 bara 378°C) and the outlet conditions were 40.5 lbs/in² abs 440°F (2.8 bara 227°C). With four flows of blading, the blade heights were 4" (101.6 mm) on a base diameter of 39" (990.6 mm) at inlet and 7.3" (185.4 mm) on a base diameter of 44" (1.12 m) at outlet. If only one double flow cylinder had been used instead, then these blades would have needed to have doubled in size ie the IP2 turbine would have been the size of an LP turbine. This perhaps sheds some light on the design thinking. The IP2 turbines existed because Parsons used relatively small diameters for the HP, IP1 and LP turbines. With small diameters, the stage count increased and this required the additional cylinders. In the HP turbine, the small diameter was related to the fact that Parsons was not yet prepared to build a single flow turbine at this size, so the diameter was kept down so the blade heights would be tall enough to perform well. In the IP1 turbine, the shaft diameter was limited by strength considerations and the relatively limited creep data which existed in the 1950s. In the LP turbines, the shaft diameter was linked to the new 30" last stage blades which had a base diameter of 60" (1.52 m). This would all change 3 years later in 1961 when Parsons designed their first single line 500 MW units, but in 1958 Thorpe Marsh was built with 8 cylinders.

The materials of the IP2 turbines were 3 CrMo for the shafts, carbon steel for the casings and 12 CrMo for the blades.

The LP turbines were conventional Parsons designs with 12 Cr fixed blades, 12 CrMo moving blades and a new 12 CrMoNiNbV steel for the last stage moving blades. The rotor centre shaft was 2½ CrMo, the discs were 3 NiCrMoV steel and the casings were made from carbon steel.

Sir Claude Gibb constructed a new Mechanical Engineering Research Laboratory (MERL) in 1957, so that nuclear CO₂ circulators could be tested and developed together with scale model steam & air turbines and wind tunnel facilities, fig.151. These were used to test the Thorpe Marsh LP turbine blades before they were used and the wind tunnels were employed to develop new LP turbine exhaust hoods which achieved much better performance than the 100 / 120 MW designs.

There was one weakness in the LP turbine shafts. During the 1950s, narrow 'heat relief' grooves were introduced in the gland regions of turbine shafts and within some bladepaths, fig.152. If any rubbing occurred against radial seals, then this could produce substantial heat transforming the surface of the shaft into hard, brittle martensite and potentially cracking the shaft. The narrow grooves were intended to allow the surface material to expand when heated and so reduced the stresses which could occur. In practice, the grooves represented stress raisers which could initiate cracks by high cycle fatigue under the self-weight bending stresses of the rotor. Most of these grooves developed shallow cracks. In seven machines, cracks developed which substantially passed through the thickness of the shaft. These were discovered before the shafts parted in two except at Thorpe Marsh. In 1979, a crack developed in the end gland of the B line LP2 turbine rotor and severed the shaft into two pieces while the machine was on turning gear. As a consequence of this and other experience, Parsons reprofiled existing narrow grooves to reduce stress raising effects and the feature was discontinued in new units.

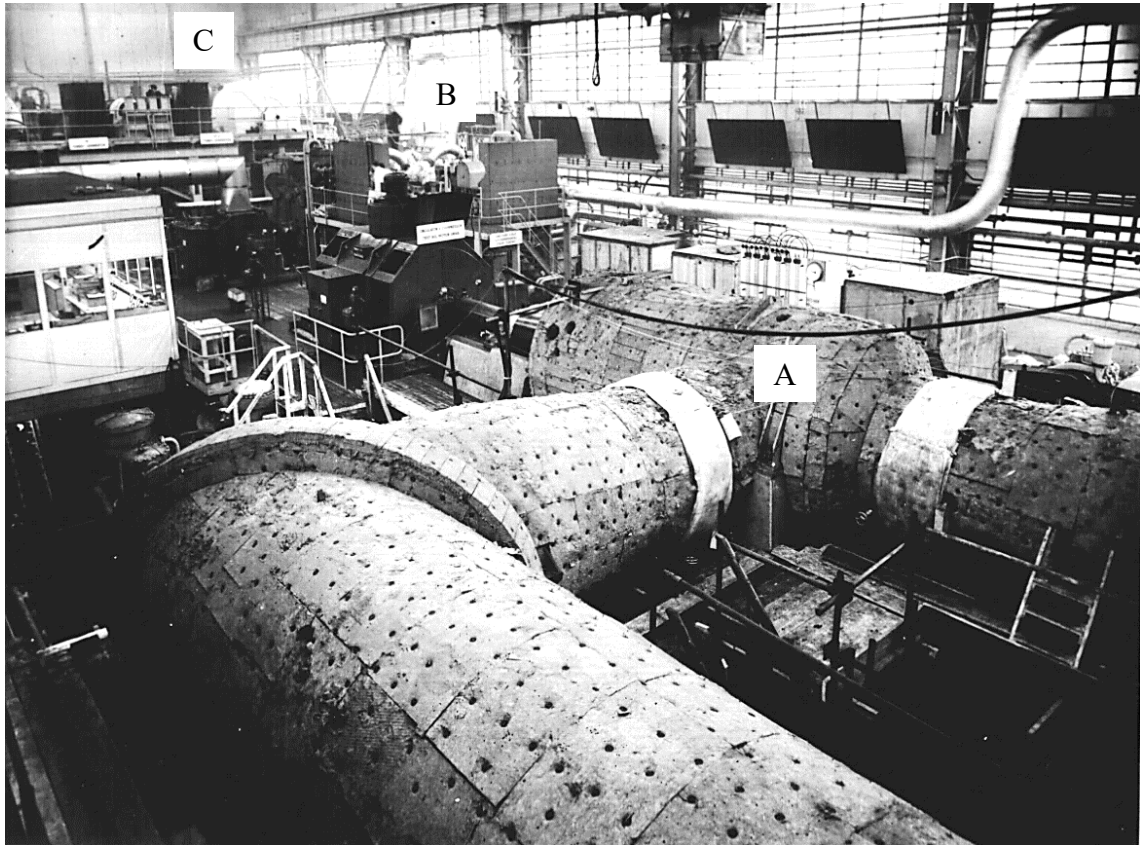

Fig.151 Photograph inside the MERL showing a Bradwell CO₂ circulator on test (A), the Bess third scale 9,000 revs/min LP turbine (B) and two variable speed 5 MW turbine-generators (C) which supplied power to some of the rigs. Please note: all of the experimental turbines at Heaton Works were named after members of Parsons family: Alice, Alicia, Anne, Kate, Bess and Mary.

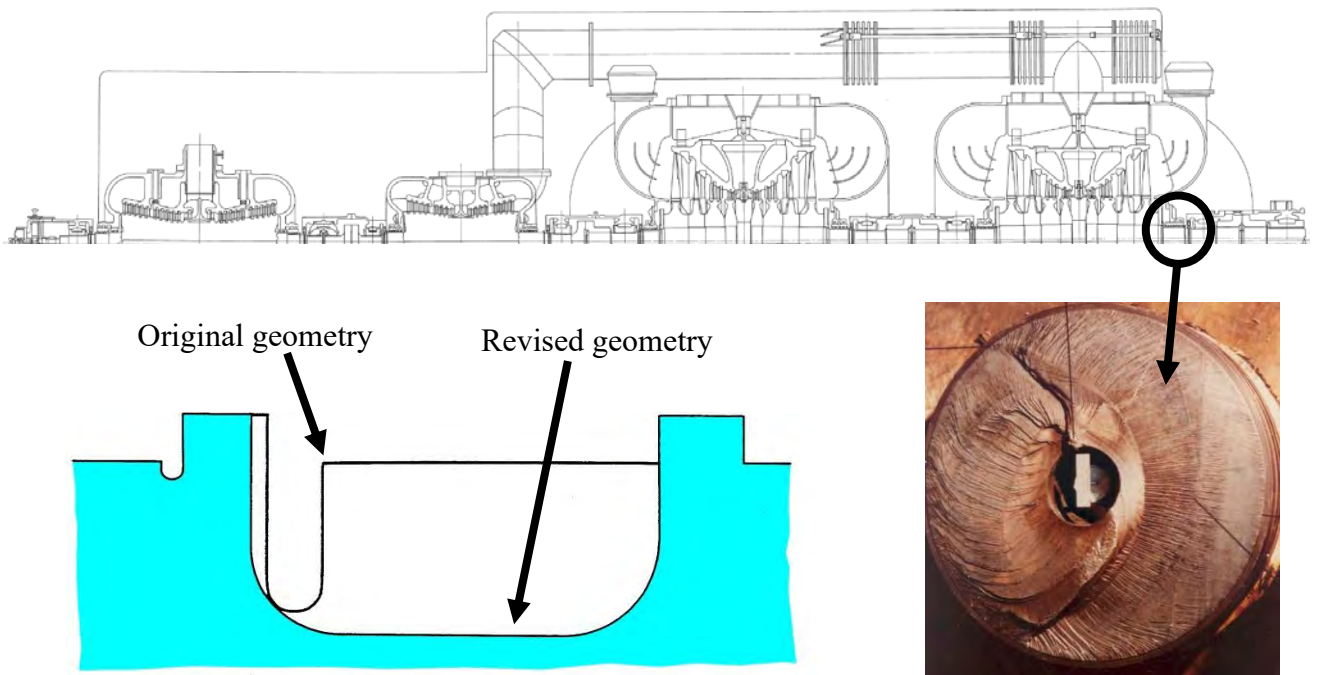

Fig.152 Fracture face and failure location in the Thorpe Marsh B line LP2 turbine rotor plus a sketch showing a typical narrow heat relief groove before and after reprofiling

Thorpe Marsh used a new type of HP steam chest. In this design, the ESV chambers were lifted up to eliminate the shared pressure wall which had been the weak spot in the Z-chest, fig.153. There were still temperature gradients in the chest body when the valves throttled but this design was better able to handle these. It became known as the L-shaped chest.

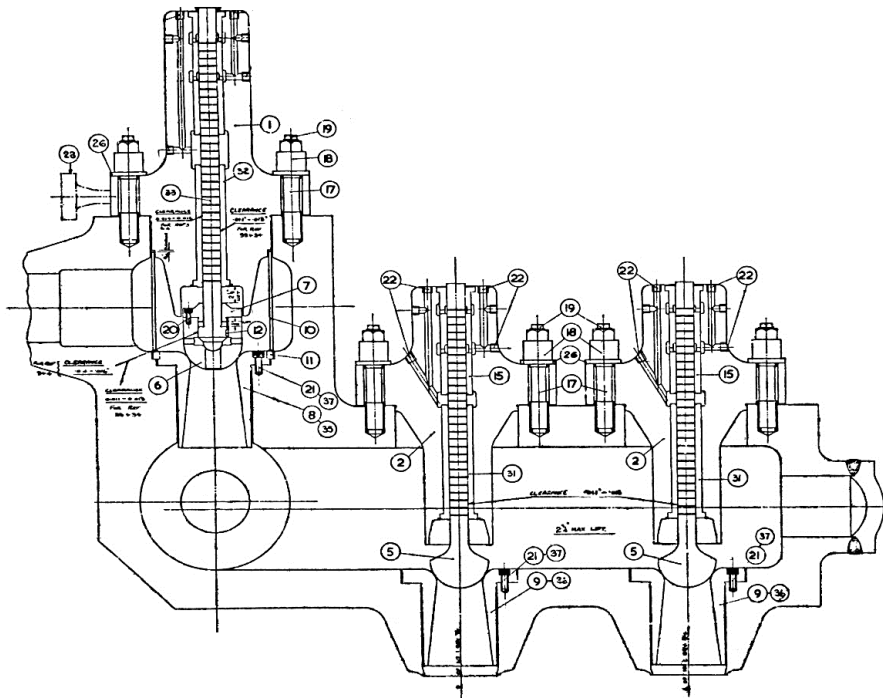

Fig.153 Thorpe Marsh HP steam chest

The HP steam chest contained two ESVs side-by-side as shown in fig.154. It was open die forged using 1 CrMoV steel, and so still looked outwardly rectangular in nature.

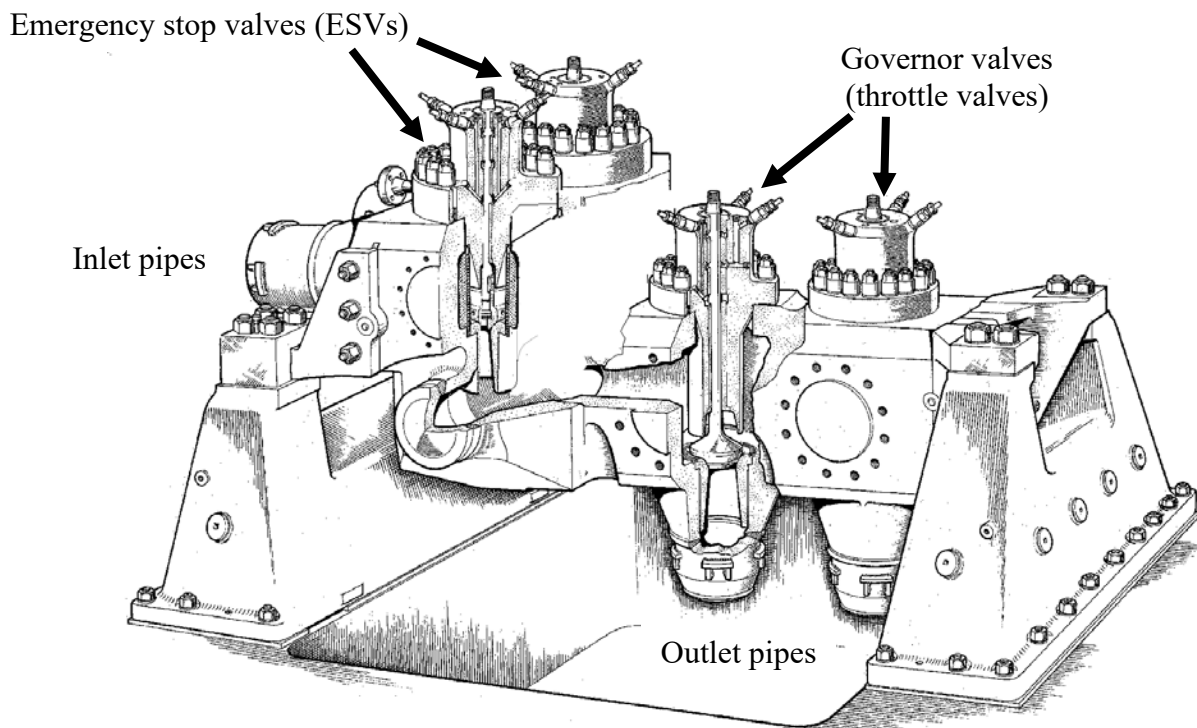

Fig.154 Thorpe Marsh HP steam chest showing the arrangement of the ESVs

The steam chest was remarkably compact for a 550 MW design and this led to some high stresses in the walls. Fig.155 shows a cross-section through the ESV chambers. An opening was machined between the two top chambers to allow on-load valve testing. This created a ligament between the two ESV seats marked in the sketch which operated with an average section stress of 40 MPa. This was approximately equal to the 100,000 hour creep rupture strength of the material (although the original designers didn't know this as long term creep data didn't become available until well after the unit was operational). So, after 100,000 hours service, this ligament started to deform and crack. In practice, the steam chest could remain in service for up to 130,000 hours before needing replacement, which was 1.3 times the original design life. When replacement chests were ordered in the 1980s, the internal geometry was altered to increase the ligament and main wall thicknesses.

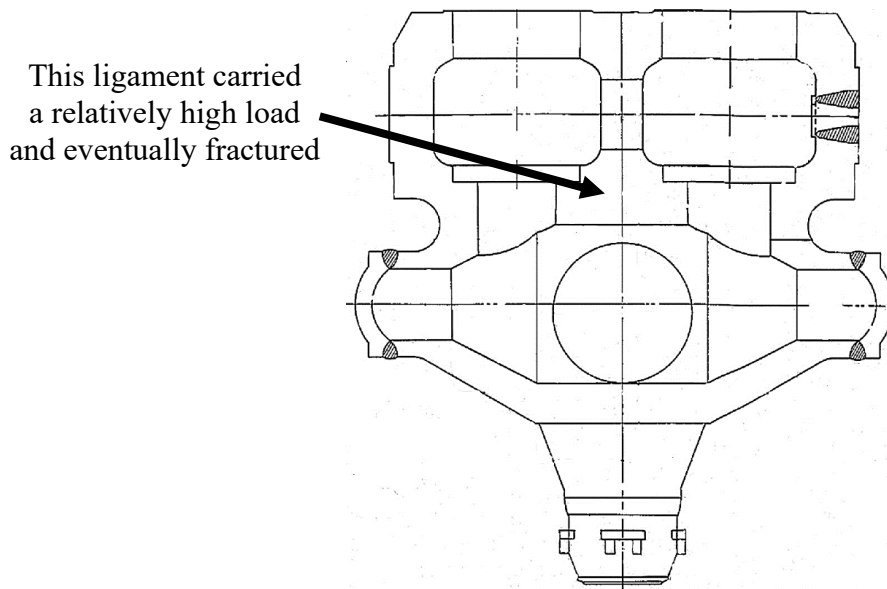

Fig.155 Cross-section through the ESV chambers showing the ligament which limited chest life



Fig.156 Cast 10 CrMoV HP steam chest manufactured in 2000. Since the expansion coefficient of 10 Cr steel was lower than the value for the Nimonic 80A studs retaining the valve covers, austenitic sleeves were fitted under the capnuts to compensate. The small pipes beneath and at the end of the chest were prewarming connections for fast starting.

A much better solution became available around 2000, when 10 CrMoV steels with up to 3 times the creep strength of 1 CrMoV became available. These high alloy chests were not used at Thorpe Marsh as the station had already closed, but they were installed in place of other 500 MW chests of this type at Ferrybridge C and Ratcliffe. Fig.156 shows a 10 CrMoV Ferrybridge C steam chest, where the chest body was cast, not forged, to allow uniform wall thicknesses to be used.

The four HP loop pipes followed convoluted paths to ensure that they were flexible enough, fig.157a and b. Eight loop pipes were provided for the IP1 turbine, feeding four inlets on the turbine casing, because the pipe diameter was larger than the HP pipes. These pipes had thinner walls due to the lower pressure and so were routed more directly to the turbine.

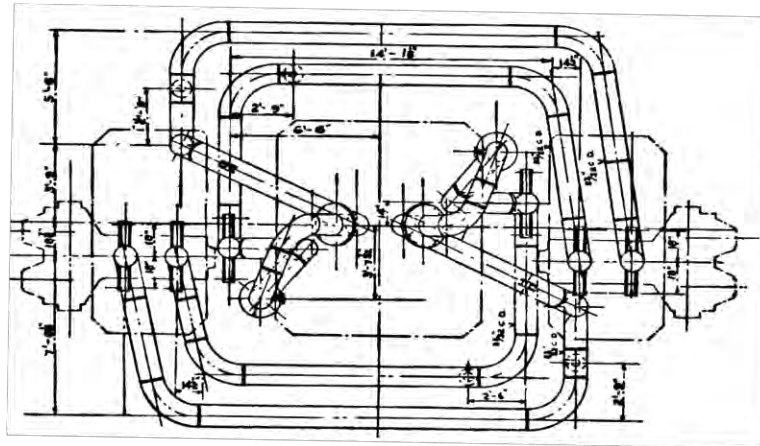

a Plan view of HP turbine loop pipes

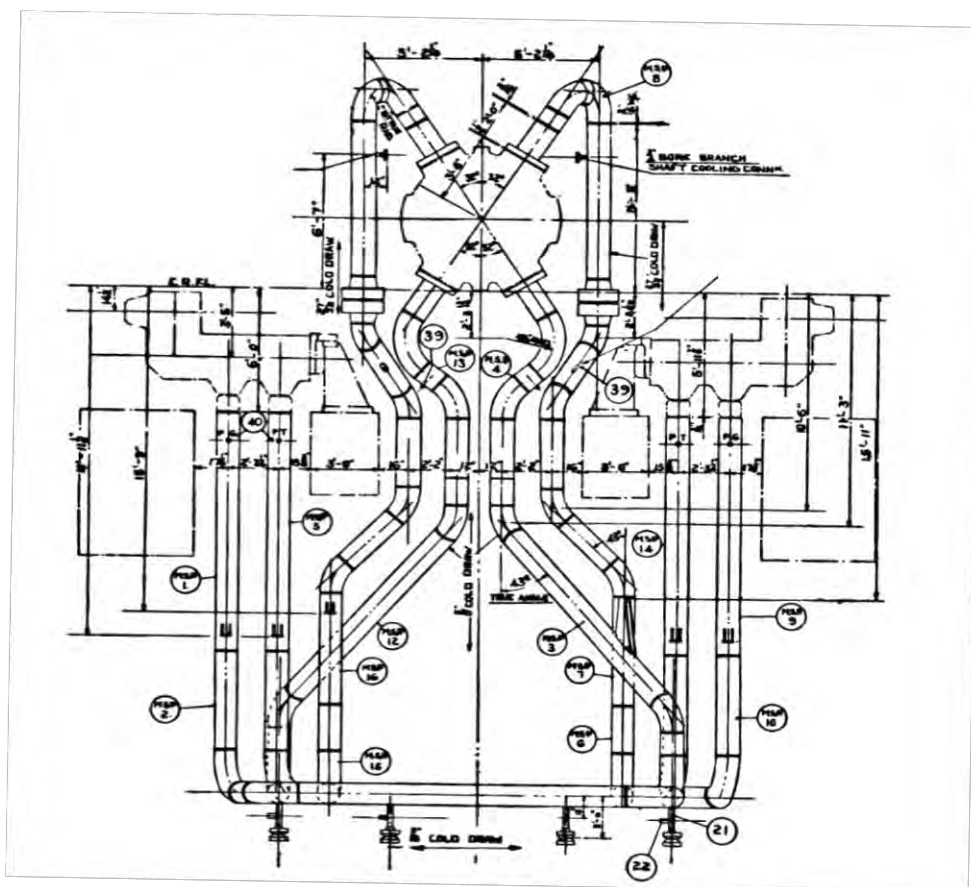

b End view of HP turbine loop pipes

Fig.157 Thorpe Marsh loop pipes joining the two HP steam chests to the HP turbine outer casing



Fig.158 Thorpe Marsh turbine hall showing Unit 1. The two shaft trains were arranged in line with each other, not side-by-side as at other cross-compound stations.

TVA Colbert Unit 5 500 MW 3,600 revs/min cross-compound turbine

Colbert Unit 5 was the last contract negotiated by Sir Claude Gibb. He died of a heart attack on 15th January 1959 at Newark airport, New Jersey while travelling from a meeting with Tennessee Valley Authority to Toronto for a meeting with HEPC. The unit had a nominal rating of 500 MW but was designed to achieve 562 MW with all of the inlet valves wide open.

The design of the machine followed the lines of the Thorpe Marsh unit, but there were some key differences. Firstly, being a 60 Hz unit, the turbine was dynamically equivalent to an 809 MW machine running at 50 Hz. In other words, it was much more highly rated than Thorpe Marsh. Secondly, the higher speed of rotation reduced the stage count and so there were only six cylinders instead of eight. Thirdly, the turbine was nozzle governed. The unit remained in service until October 2013.

The steam conditions were 2,400 lbs/in² gauge 1050°F (165.5 barg 566°C) at the HP turbine inlet and 430 lbs/in² abs 1000°F (29.7 bara 538°C) at the IP inlet. There were 8 stages of feedheating. Since this unit used a boiler feed pump turbine (BFPT), which ran using steam from the HP turbine exhaust, four of the feedheat extractions came from the BFPT. This supplied steam at the correct pressure but with less superheat than taking steam from the IP turbine, which made the design of the feedheaters easier. The main turbine is shown in figs 159a and b.

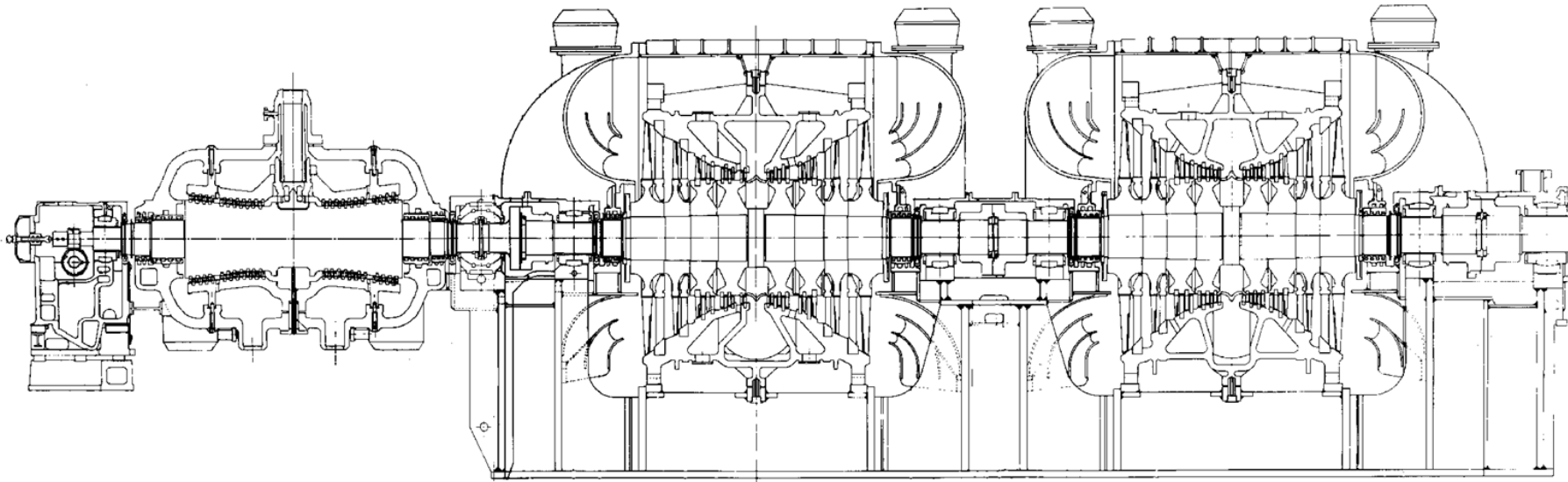

a The A line comprising the HP turbine and two LP turbines

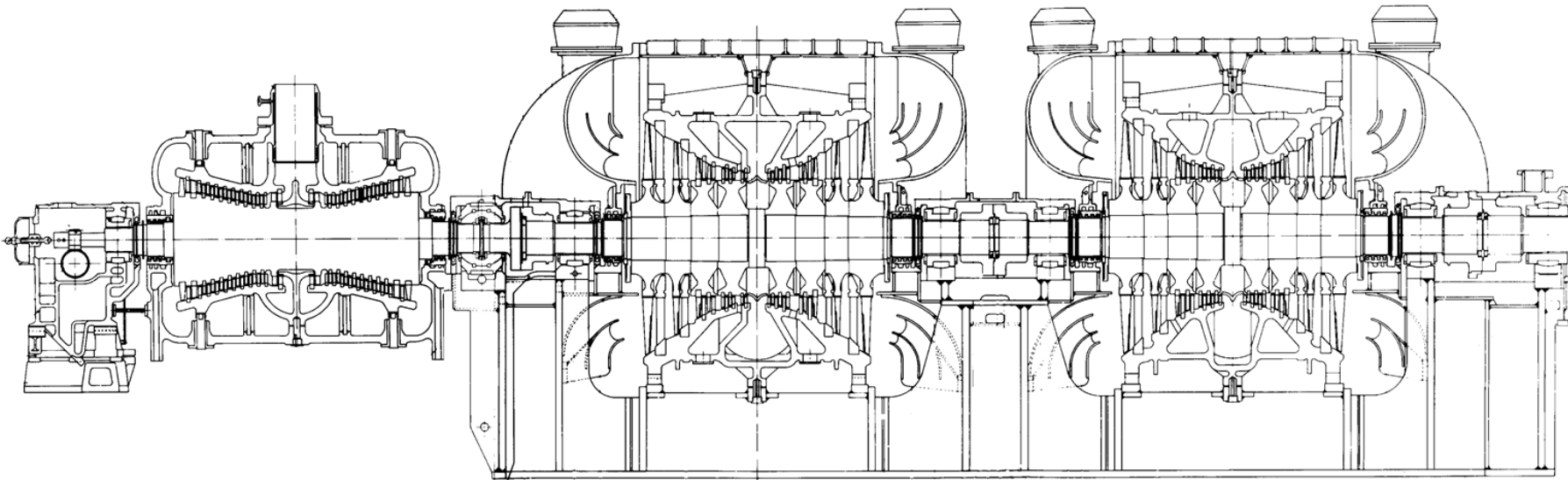

b The B line comprising the IP turbine and two LP turbines

Fig.159 TVA Colbert Unit 5 500 MW 3,600 revs/min turbine 1959

The HP turbine was double flow with a Rateau stage at inlet followed by reaction blading. The control stage had four separate nozzle chests: 2 'primary' chests containing 9 nozzles each which allowed power outputs up to 340 MW to be achieved, a 'secondary' chest containing 11 nozzles which enabled loads up to 480 MW and the 'tertiary' chest containing a further 11 nozzles to achieve the 'valves wide open' load of 562 MW. At full load, the impulse stage operated with a stage loading $U/C_0 = 0.485$, which was ideal for a Rateau stage. At low loads, with just two arcs in service, the stage loading increased to $U/C_0 = 0.237$. The impulse moving blades were installed in axial fir tree root fixings. At first, the HP turbine rotor used the same type of cooling system as Thorpe Marsh with heat exchangers to reduce the temperature of live steam, but the same issues arose and so the system was modified to 'ventilate' the space beneath the nozzle chests.

After 140 hours operation at loads up to 330 MW, some of the HP turbine Rateau moving blades detached. The unit had operated with only one nozzle arc in service, which increased the stresses in the blades massively. They failed by fatigue in the root fixing. The mechanical damage caused by the debris required a new rotor to be made. The new rotor was built with stronger root fixings. To further reduce the possibility of recurrence, the unit was changed so that 2 nozzle arcs were used up to 10% load, then 3 arcs were employed up to 85% load and the fourth arc was brought in to reach full load. In addition, sliding pressure control was adopted below 80% load. This reduced the forces on the blades substantially while minimising valve throttling losses.

In 1978, new HP impulse moving blades had to be fitted to repair solid particle erosion caused by boiler scale and the front reaction stages were changed from IFR to ILS construction. The impulse blade root pockets were found to have enlarged due to site cleaning methods and oxidation, so the blades were locked in place using wedges in the same way as LP turbine last stage blades. This didn't work and some blades again detached. A further rotor was installed; this time the design was changed to a straddle root fixing as used for earlier Curtis stages. This was much more robust in terms of its ability to handle bending stresses from steam forces. This was successful.

Parsons made two important design decisions as a result of this experience. Firstly, after 1963, no Parsons unit larger than 400 MW was ever nozzle governed. Secondly, only straddle root fixings were used on nozzle governed HP turbine control stages in units smaller than 400 MW.

The IP turbine was a double flow design with a Rateau stage at inlet followed by reaction stages. The stage loading of the impulse wheel was $U/C_0 = 0.418$ ie sufficient to obtain near peak performance. The IP rotor was cooled by injecting HP turbine exhaust steam underneath the inlet flow deflector. No problems were encountered.

The LP turbines used disc construction rotors with last stage blades which were an exact scale of the 30" long 120" tip diameter 50 Hz Thorpe Marsh blades ie they were 25" (635 mm) long with a tip diameter of 100" (2.54 m) at 60 Hz. When stress corrosion cracks were discovered in the rotor discs of some Heaton 500 MW single line units in the 1980s, new monobloc LP rotors were ordered for the Colbert unit with updated blade paths using the R series blade profile for the reaction stages and laser hardened, high twist, last stage blades. This eliminated the risk of disc cracking and achieved a performance improvement.

Figure 160 shows the unit in the turbine hall.

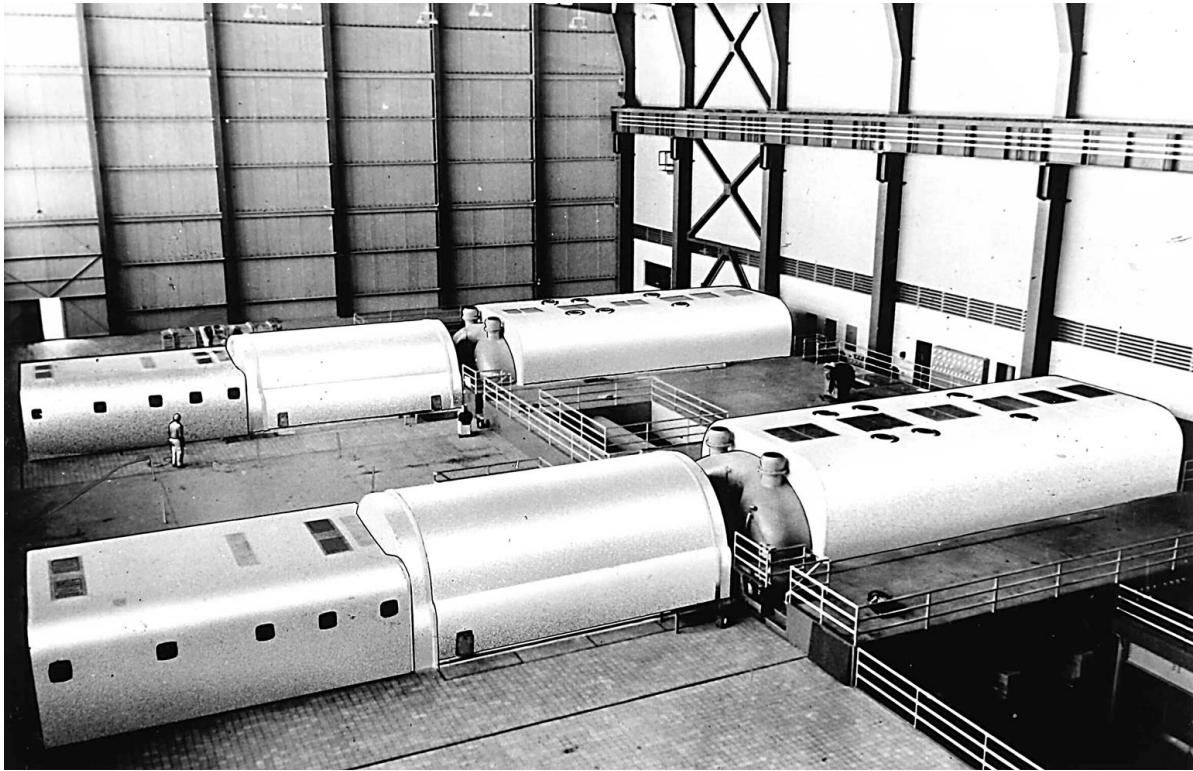

Fig.160 Colbert Unit 5 installed at site

Heaton 500 MW single line 3,000 revs/min turbines

Soon after the Colbert Unit 5 order, development work on 500 MW single line turbine-generators was sufficiently advanced for the CEGB to place orders. In March 1961, four units were ordered for Ferrybridge C power station followed in September 1962 by four units for Ratcliffe PS. One of the Ferrybridge sets was the first single line 500 MW TG to be built and commissioned in the World.

These were coal-fired units with steam conditions of 2300 lbs/in² gauge 1050°F (158.6 barg 566°C) HP, 550 lbs/in² abs 1050°F (37.9 bara 566°C) reheat and 7 stages of feedheating. New last stage LP blades were available 36" (914.4 mm) long with a tip diameter of 136" (3.45 m). The units could have been built either with four exhaust flows to minimise the initial capital cost or with six flows to minimise leaving losses. Six exhaust flows were adopted since the saving in fuel costs far outweighed the cost of a third LP turbine. The condensers were underslung using the Thorpe Marsh exhaust hood geometry. The turbines were throttle governed.

A cross-section through the turbine line is shown in fig.161. The turbine hall at Ferrybridge C is shown in fig.162.

In early 1963, an order was placed for four oil-fired units for Fawley PS near Southampton. The steam temperature was reduced to 1000°F (538°C) at both the HP and IP stop valves due to the detrimental effect of oil firing on the boiler. The TG sets were notionally the same as Ferrybridge C and Ratcliffe except that two pannier condensers were used, fig.163, and some direct contact feedheaters were employed. Pannier condensers achieved lower exhaust losses than underslung condensers and reduced the height of the turbine hall at the cost of increased floor area. These were used by many manufacturers in the 1960s.

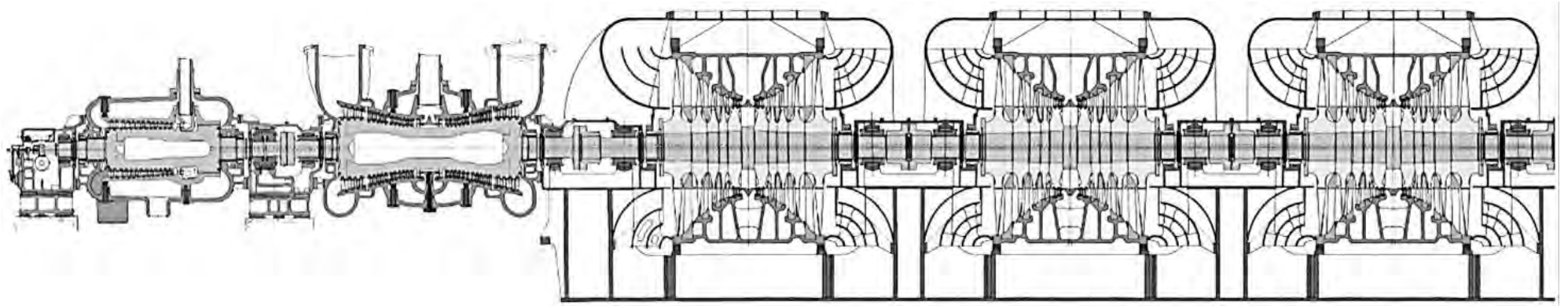

Fig.161 Cross-section through the turbine line for Ferrybridge C and Ratcliffe power stations 500 MW 3,000 revs/min 1961

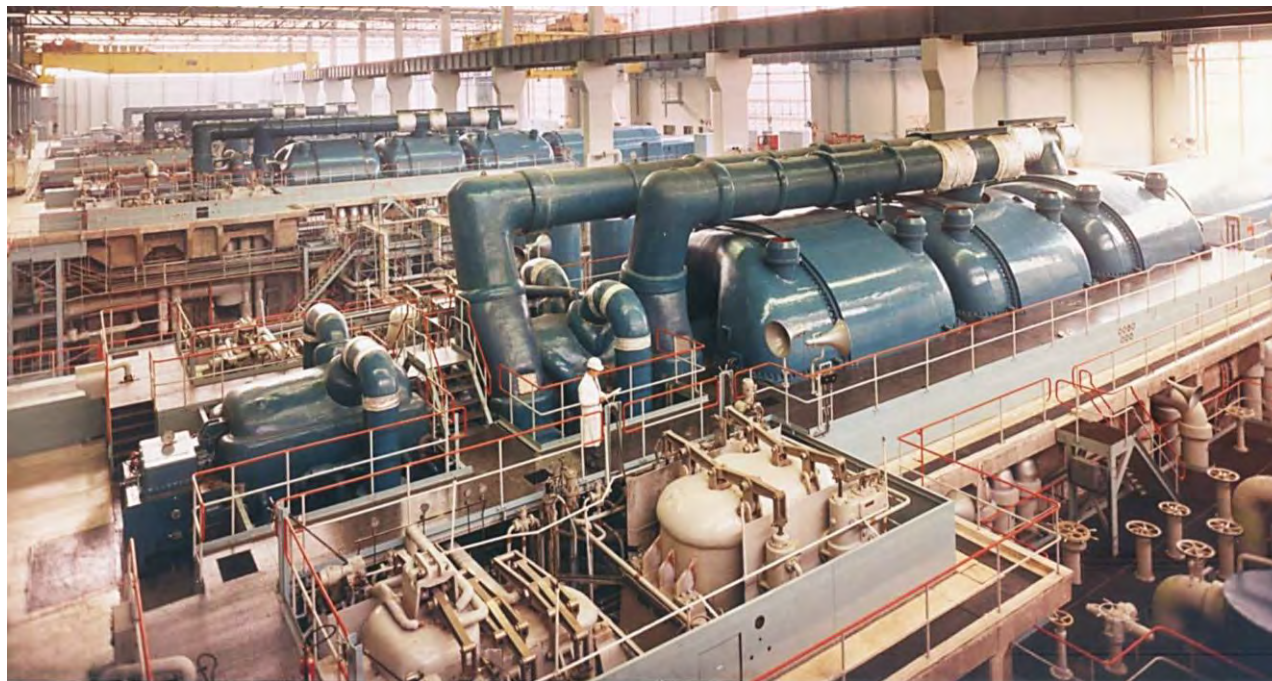

Fig.162 Four 500 MW TG sets in Ferrybridge C turbine hall

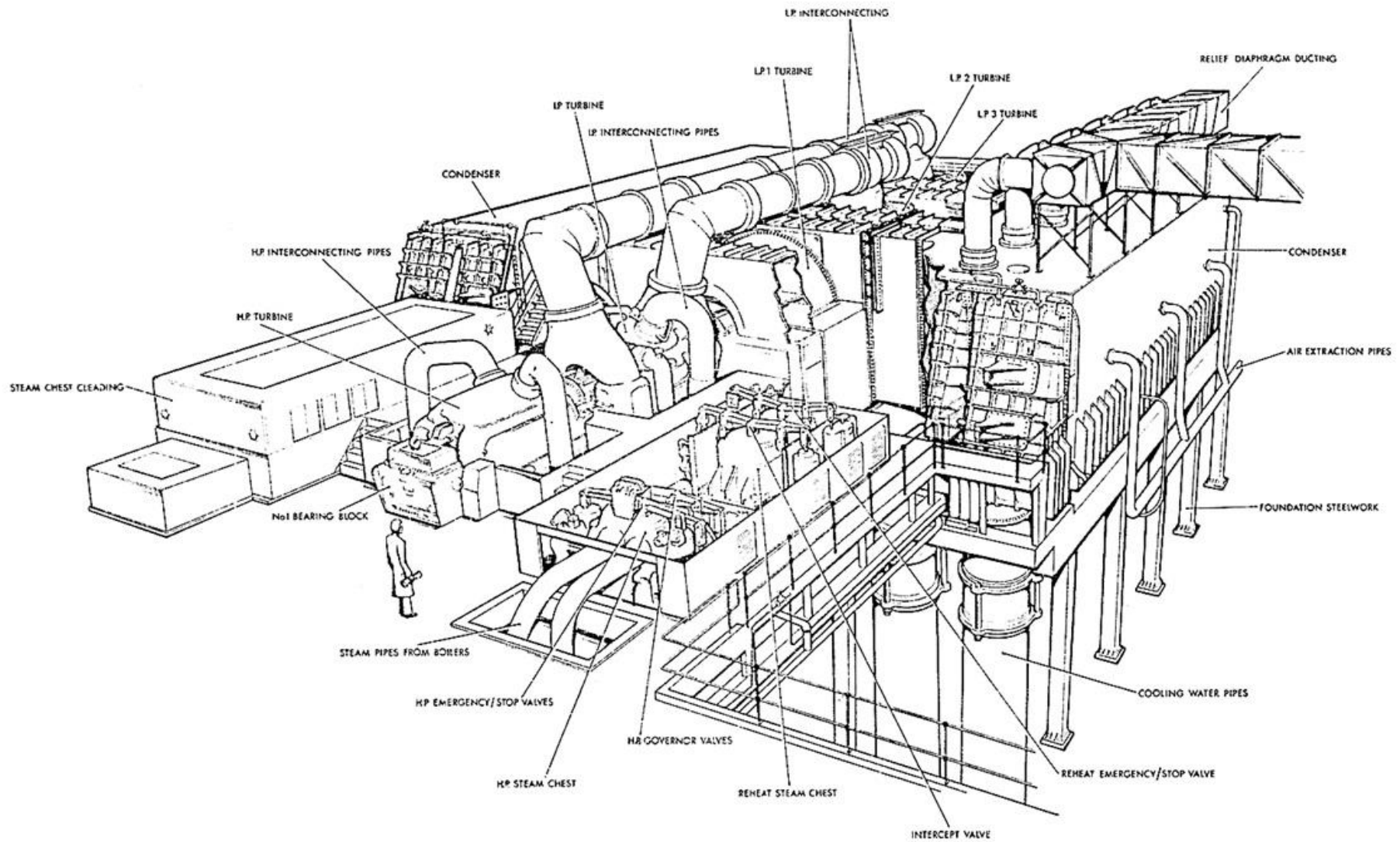

Fig.163 Sketch showing the arrangement of the pannier condensers at Fawley 1963

Direct contact feedheaters allowed steam taken from the turbine to mix directly with the boiler feedwater, rather than transfer heat through a tube and shell heat exchanger, to give a small thermodynamic advantage. These were adopted at many stations during the 1960s. It was found that the sudden drop in pressure in the bladepath which occurred on a turbine trip caused the water in the feedheaters to flash into steam and carry water back into the turbine damaging the blading and causing casing distortion. Many stations subsequently changed these to conventional tubed heaters.

Following Fawley, units were also installed at Rugeley B (coal-fired), Pembroke and Ince B (oil-fired) using the standard steam temperatures of 1050°F for coal-fired boilers and 1000°F for oil-fired. The steam flows inside each machine differed slightly but the bladepaths were designed so that the rotor trains were interchangeable between any unit. This allowed two rotor trains to be held as 'National Spares' for the fleet. These units became known as the 'Heaton 500 MW sets' to distinguish them from the 'Erith 500 MW sets' built by GEC at their factory at Erith in Kent which became part of the Parsons fleet in 1965, see next chapter.

(a) HP and IP turbines

The HP and IP turbines employed a Rateau stage at inlet followed by reaction blading. The blades were made from 12 CrMoV steel with ILS type moving blades apart from the last 4 IP stages which were open-tipped and laced. ILS construction means that the shroud platform was placed centrally relative to the aerofoil to eliminate the risk of shroud lifting which had affected IFR blades. This form of construction was used subsequently for all high temperature reaction blades in all large Parsons turbines. The blades were formed into segments using dip brazing, which by the 1980s, was superseded by vacuum brazing. Fig.164 shows a typical reaction blade segment.

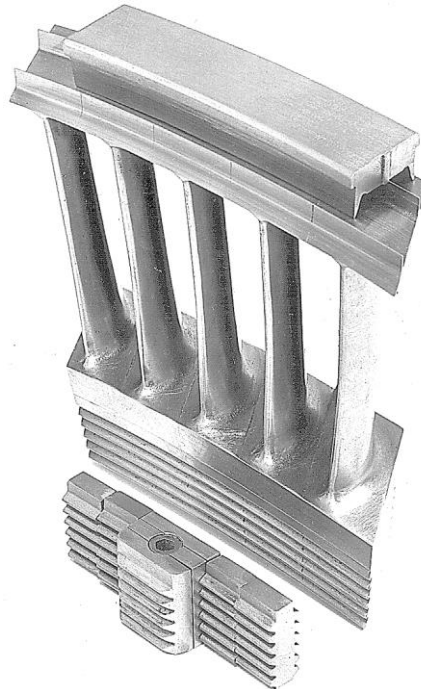

Fig.164 A typical high temperature ILS reaction blade segment together with the tip seal which was fitted in the casing and the side locking strip which held the blades in a circumferential groove.

The HP and IP turbine rotors were hollow-and-stub designs with 1 CrMoV main bodies. These worked reasonably well at first allowing hot starting after an 8 hour shutdown within 30 minutes from turbine roll to full load, for example. However, some of the rotors started to develop a bend.

The first IP rotor to enter service developed a bend of 0.0056” (0.14 mm) after 6,500 hours. As further units were commissioned, fourteen HP and IP turbine rotors also developed bends. This represented around one third of the 500 MW fleet. The largest bend was 0.019” (0.48 mm) after approximately 30,000 hours although most rotors experienced less than this.

Investigation showed that the root cause was the manufacturing process at the forgemasters [16]. Three factors were noted:

- Two of the IP rotor forgings which developed a bend had been machined with the hollow off-centre.
- Some rotors had been heat-treated horizontally without continuous rotation.
- Other rotors had been heat-treated vertically.

It was found that the main issue was heat-treating the rotors horizontally without continuous rotation. In this process, the temperature difference between the top and bottom of the forging was kept within 30°C (actual values 960°C and 930°C respectively). The forging was turned once through 180° two-thirds of the way through the tempering cycle. Steam quenching – which had been used for earlier hollow rotors (which did not bend) – was changed to oil quenching for the heavier 500 MW rotors. This requirement prevented the rotors from being turned continuously with the equipment available at the forgemasters.

A trial forging was made and destructively examined so that the properties at many different positions could be measured. It was found that there were small differences in creep strength on each side of the forging sufficient to cause the bending in service. The density of the precipitate V₄C₃ differed on each side of the forging and this strongly influenced the creep strength. Consequently, vertical heat treatment of rotor forgings was adopted and the temperature variances during heat treatment were tightened. Since so many of the hollow-and-stub rotors were affected and the industry was moving towards solid monoblocs at this time, it was decided to discontinue the manufacture of hollow rotors for large high temperature machines from the mid-1970s onwards.

The HP turbine casing was double shell construction with separate nozzle chests made from 1 CrMoV steel. The highest feedheat extraction was taken from midway along the outer casing to promote cooling of the inner casing, fig.161. As mentioned earlier, while this was the design logic of the 1950s and early 60s, the temperature behaviour inside the machines was studied closely with extensive thermocouple surveys taken in particular from Fawley. In 1973, this led to a decision to take the feedheat steam from the cold reheat pipes rather than from the turbine casing and to include an integrally cast baffle in the design of the inner casing to prevent the cold exhaust steam from chilling the hot surfaces of the inner casing too much, fig.165. In addition, internal pipes were used to route the leakage steam from the dummy piston to the exhaust so that the hot steam did not touch the outer casing.

This form of construction was successful and was used for all subsequent large Parsons HP turbines with changes only in materials and detail features such as fillet radii and other stress raisers.

The IP turbine casing was partially double cased in the first 3 power stations, fig.161, and was then changed to fully double cased construction as experience was gained. As with Colbert Unit 5, feedheat extractions were taken from the boiler feed pump turbine rather than the IP turbine. With no steam being taken from the IP blade path, the blades in the right and left hand flows were made slightly different to ensure that there was a small flow of steam passing through the space between the inner and outer casings for cooling.

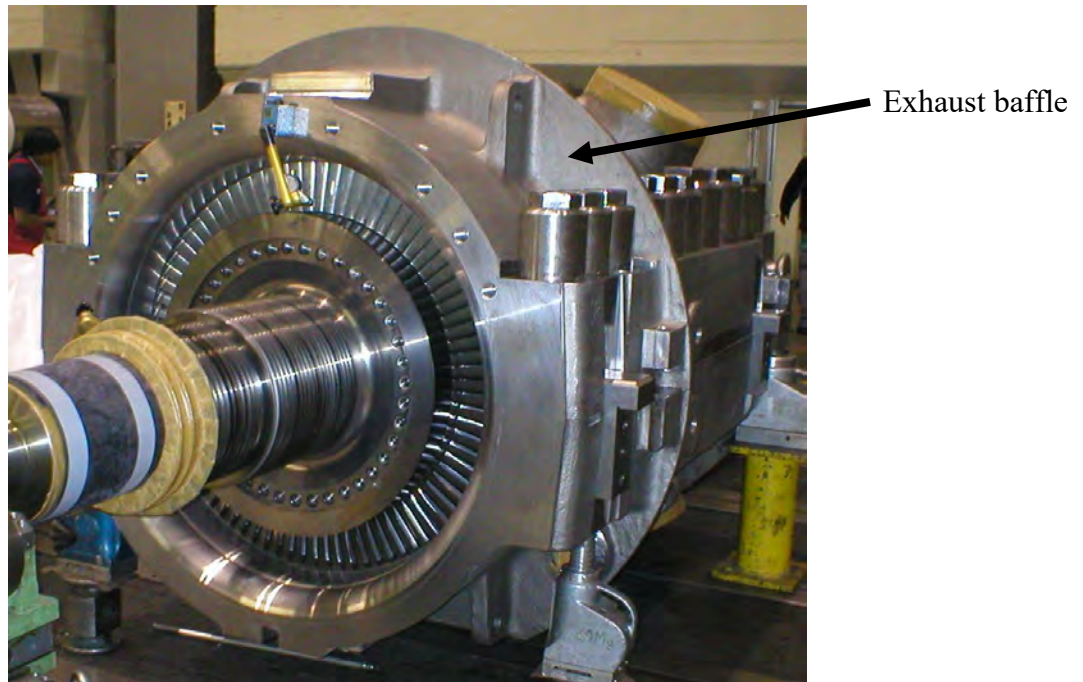

Fig.165 Parsons 500 MW HP turbine inner casing showing the exhaust baffle

(b) LP turbines

The LP turbines employed six stages per flow. The first two stages used shrouded 50% reaction blades similar to those in the HP and IP turbines. The last four stages employed open-tipped, laced, moving blades with axial fir tree root fixings and brazed erosion shields. The key issue with the blades was the risk of fatigue cracking in the root fixings. There were four stress raising features which were superimposed: the C-shaped locking groove, the root serrations, the overhang of the base section of the aerofoil and the angle of the root relative to the disc head. In addition, blade fit in the 1960s was variable and molybdenum disulphide grease was used to fit the blades which was later found to be aggressive to turbine steels. The blade row which was most vulnerable to cracking was the L-1 stage. Here, the wet environment reduced the fatigue endurance of the material and the higher temperature in the L-1 stage compared with the L-0 stage, for example, increased this effect. In addition, the L-1 blade tended to be more highly cambered than the L-0 stage and so stress raising effects tended to be higher.

The first attempted solution involved removing the C-groove by forming an undercut as shown in fig.166b. This left the blade root platform and the aerofoil untouched. The undercut actually made the stress raising effects worse, although this wasn't apparent until 3D finite element analysis (FEA) became available. As soon as 3D FEA could be used, a better modification was developed in which the C-groove was removed by machining straight up the side of the root block, fig.166c. This removed a small amount of the aerofoil trailing edge. At the same time, other stress raisers were modified (eg larger root neck radii and radiused corners on the edges of the root block), shot peening was applied to induce beneficial, compressive residual stresses and acid etching was used to adjust the fit so that a controlled clearance was achieved on every blade. Molybdenum disulphide grease was banned. With the C-groove removed, the blades were locked using a tapered wedge fitted beneath the root block, fig.167.

These modifications were successful. No further cracking occurred in any of the modified blades even after service lives of up to 300,000 hours (3 times the original design life).

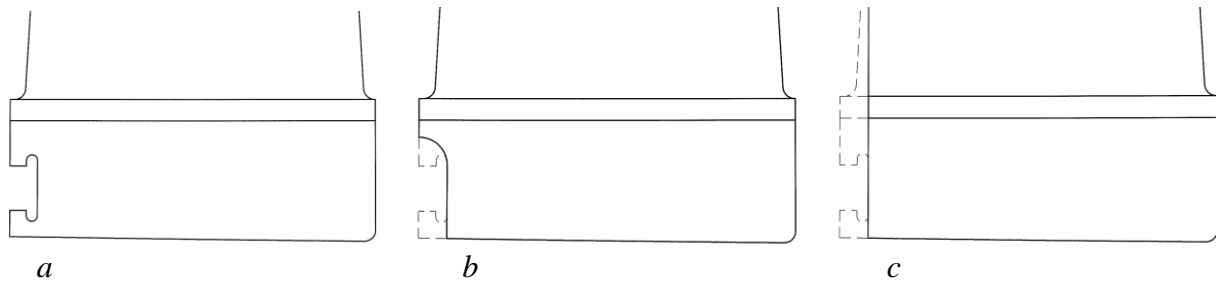

Fig.166 Parsons 500 MW LP blade root fixing geometries, *a* original C-shaped locking groove, *b* first modification: an undercut and *c* final modification: a straight cut



Fig.167 Parsons fir tree root fixing after modification

In the 1970s, computational fluid dynamics (CFD) software tools became available. These were applied to the 500 MW LP stages to analyse the flow and see if a performance increase could be obtained. The blades had originally been designed using hand calculation methods and then validated using Bess, a third scale model steam turbine. The moving blades had a linear twist along their length and the diaphragm blade had a relatively narrow chord, with a constant, untwisted section. Analysis showed that the flow tended to migrate towards the outer flow boundary. This left the hub region depleted. The blades operated with higher local velocities than intended, negative reaction occurred near to the hub linked to adverse pressure gradients and there was a large area of supersonic flow around the root section of the moving blades. The non-uniform mass flow distribution led to increased leaving losses [17, 18, 19]. In the early 1980s, updated fixed and moving blades were designed which had a non-linear twist along their length and these were used together with twisted, tapered and leaned diaphragm blades. The lacing wires were eliminated and replaced by a tip strut to create a smooth undisturbed aerofoil profile. The moving blades had much more twist towards the tip section than previously and for this reason, they were named “high twist blades”, fig.168.

Revised L-0 moving blades plus new L-1 and L-0 diaphragms were fitted to existing turbines. This simple change achieved an improvement in heat rate of 1.5 – 1.9 percentage points which provided rapid payback to each station.

Figure 169 shows one of the Parsons 500 MW LP turbines. The discs and centre shaft were made from NiCrMoV steels. In the 1960s, acid open hearth steels were used at first which could suffer poor toughness ie K_{IC} values were down to around $30 \text{ MPa m}^{1/2}$ at 20°C in the worst cases. By the early 1970s, basic electric arc steels were used predominantly with much better toughness values. Rotors built after 1973 had a fracture toughness up to $165 \text{ MPa m}^{1/2}$ at 20°C .



Fig.168 Comparison between the original 500 MW last stage blades, *left*, and high efficiency, high twist blades, *right*

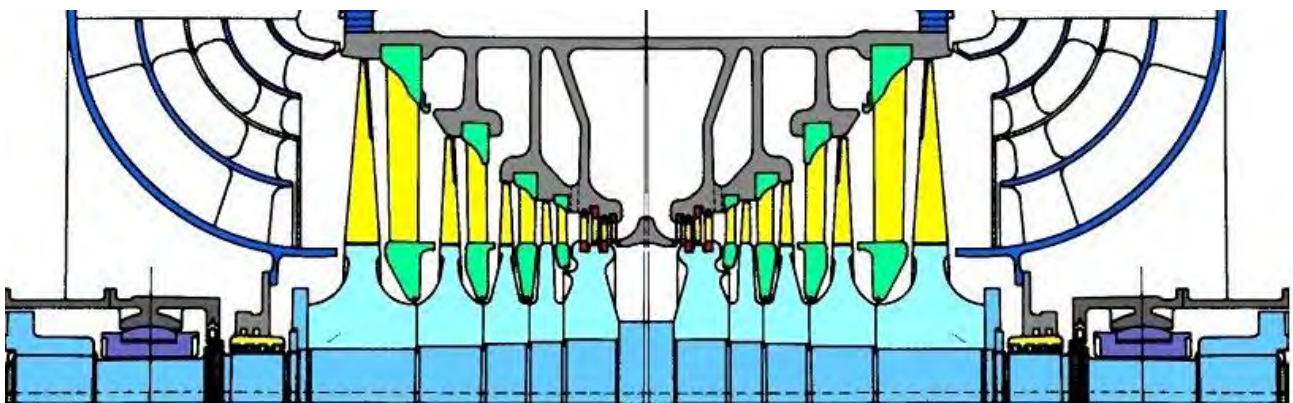

Fig.169 Parsons 500 MW LP turbine

In 1972, a large high cycle fatigue (HCF) crack was discovered in one of the 500 MW LP rotors, fig.170. It was located at the centre collar of the pencil shaft. Further cracks were found in other LP rotors in 1973. This was the first indication of a new phenomenon. HCF cracks affected the rotors of several manufacturers during the 1970s. An investigation concluded that as machine size increased, the fatigue strength of the shaft forging reduced. For shafts with a diameter of 200 mm or above, the endurance was approximately halved compared with data obtained from standard test specimens in the 1960s [20].

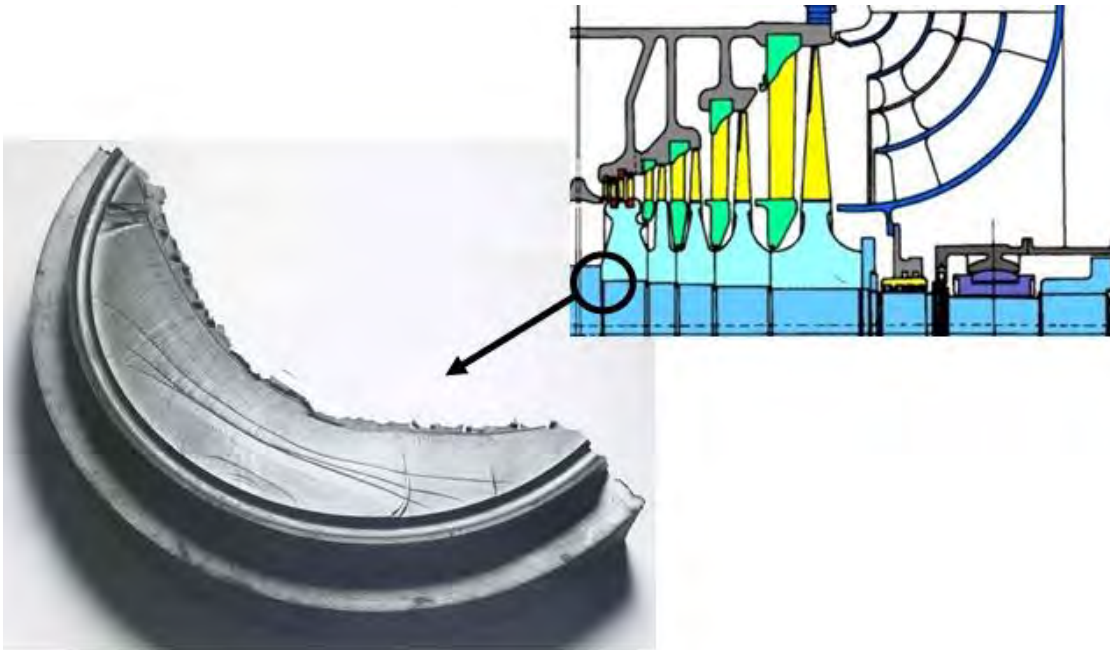

Fig.170 High cycle fatigue fracture surface from a 500 MW LP centre shaft

Contributory factors included:

- a high stress concentration factor created by the centre collar (a large step in diameter with a modest fillet radius)
- the steady axial stresses created by the shrink fit of the discs
- the alternating bending stresses in the shaft produced by the self-weight of the rotor plus any variances in alignment at the couplings.

All of these factors worked together to induce a high cycle fatigue mechanism.

The centre collar was large in diameter to assist balancing the rotor. The collar was eliminated in subsequent designs and replaced by a separate balance weight disc, fig.171. Only a small step remained in the pencil shaft to register the inlet discs. In addition, the fillet radii at each change in shaft diameter was optimised using finite element analysis and the shrink fit of the discs was reduced.

It's important to understand the role of the discs in this mechanism. When the discs were shrunk on to the shaft, they squeezed the shaft. This produced compressive stresses in the hoop direction, and tensile stresses in the axial direction due to Poisson's ratio. The axial stresses were multiplied by the stress concentration factor at any change in diameter. This represented a steady stress which affected the HCF life. When the unit ran up to full speed, the discs expanded due to CF forces, the interface pressure between the discs and the shaft reduced and the axial stresses fell. The highest stresses in the pencil shaft therefore occurred at barring speed when there was no significant growth of the discs. Life management therefore involved checking the HCF life of the shaft at both full speed and barring speed.

In the 500 MW units, the barring speed was reduced from 30 revs/min to 3 revs/min and the length of time spent on barring was minimised to reduce the number of cycles which could accumulate at the highest stress state. It also became standard practice to maintain a log of the number of barring hours so that the remaining life of the shaft could be quantified.

With these measures, the centre shafts operated well and no cracks recurred.

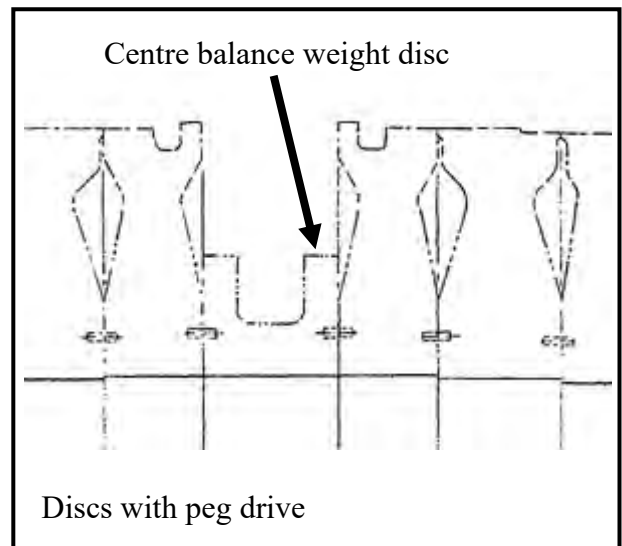
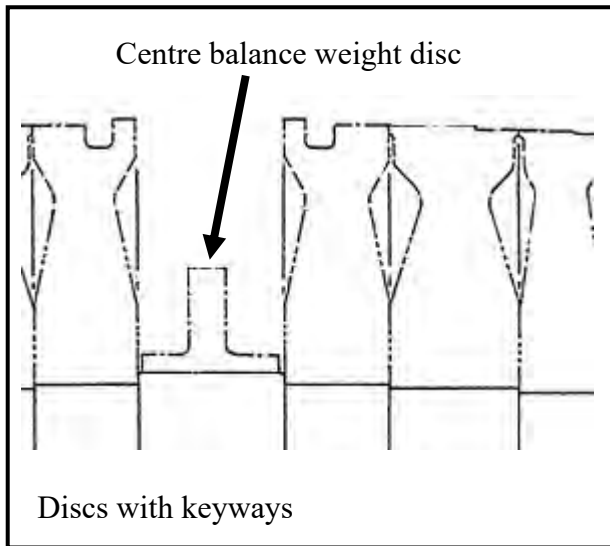

Fig.171 Typical modified Parsons disc-type rotors where the centre collar has been replaced by a separate balance weight disc. Note: there is hardly any step in diameter in the shaft surface.

When an English Electric disc-type LP rotor burst at Hinkley Point in 1969 due to stress corrosion cracking at the disc bore, manufacturers including Parsons reviewed their fleets and this led to the modification of many non-reheat LP shafts. The rotors of reheat, fossil-fired turbines were also examined, but no cracks were found until 1985 when small cracks were found in a rotor from Fawley. This led to further studies and the assessment of LP rotor discs in all Parsons reheat units.

During these studies, in 1989, a combined IP/LP rotor in an English Electric 200 MW reheat unit at High Marnham suffered a disc burst from a large crack [21].

Many rotors were modified. Discs with particularly low toughness were scrapped. Other rotors were dismantled and the discs were converted from keyway to peg drive. This involved increasing the disc bore to remove the keyway which was a stress raiser, minimising the shrink fit and then installing a peg in the side of each disc to locate them, fig.172.

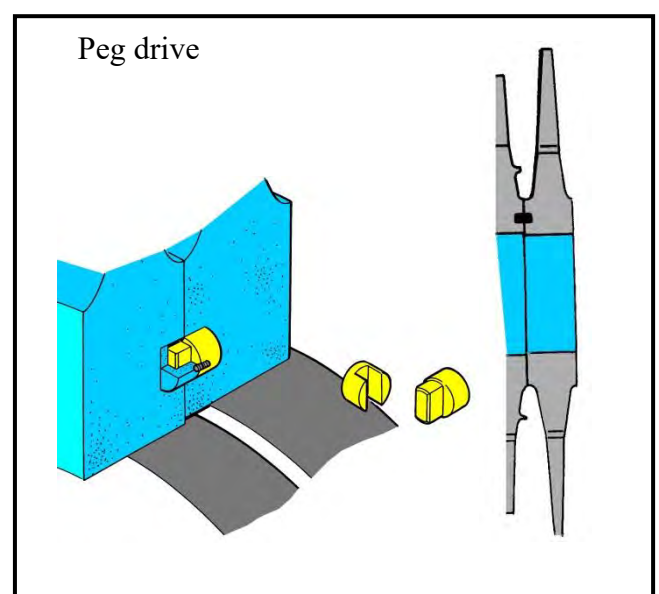
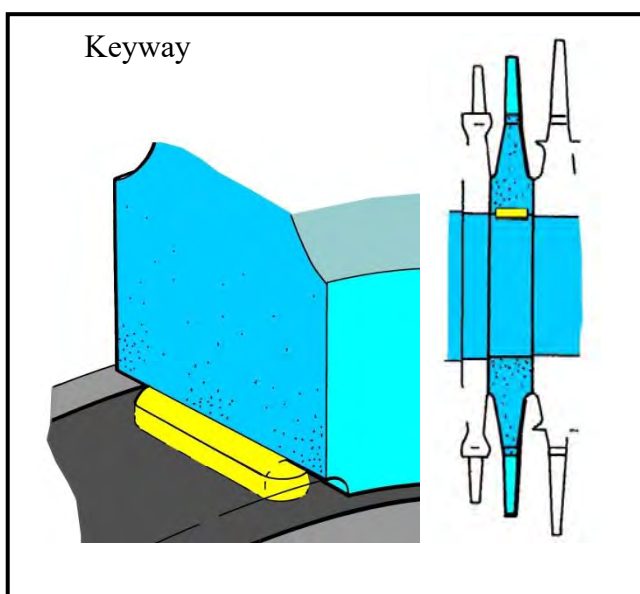

Fig.172 Alternative methods of locating LP turbine rotor discs

Two types of crack were observed in the 500 MW fleet, fig.173. The discs close to the inlet which operated in superheated steam showed open-mouthed transgranular cracks. These were generally no more than 0.5 mm deep after 56,000 to 112,000 hours service. Since the discs were expected to run dry once they were at steady load, wetness should have occurred only during cold and warm starting. The appearance of the cracks suggested that the mechanism was corrosion-fatigue, which seemed consistent with short periods of repeated wetness. However, with later knowledge, it became apparent that these were a variant of stress corrosion cracking.

In the discs close to the exhaust which ran continuously wet, the cracks were classical intergranular stress corrosion cracks, fig.173. These were up to 4.6 mm deep.

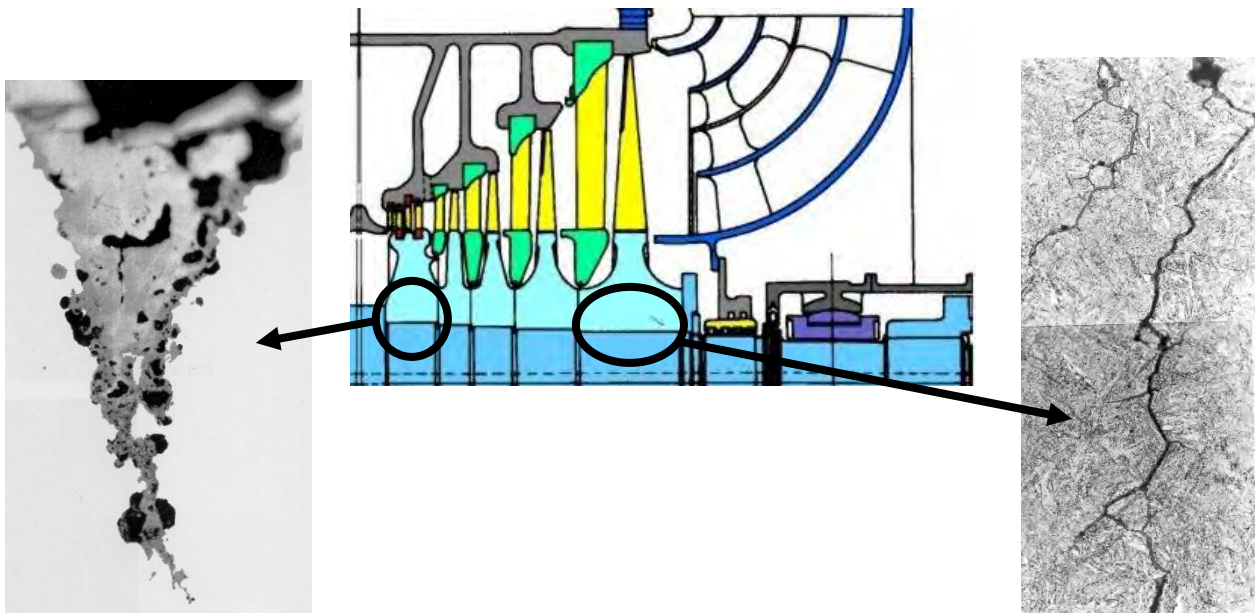

Fig.173 Crack appearances found in 500 MW discs

The crack on the *left* is approximately 0.5 mm deep, the crack on the *right* is around 2 mm deep

In Pembroke Unit 2, a 15 mm deep crack was found after 56,000 hours in the inlet disc. This was located in one of the hot inlet discs but the crack had an intergranular appearance similar to the wet region cracks. It was almost diametrically opposite the keyway on a plain section of the bore and it was approximately 100 mm from the front edge of the disc. This showed that water could enter the plain bore region where the interference fit acted and stay there for prolonged periods.

This experience led to a widely held view that it was preferable to use monobloc or welded rotors rather than shrunk disc rotors, and so in the 1980s, the number of shrunk disc rotors being built reduced.

However, this was a false impression. While stress corrosion affected disc-type rotors first, it affected monobloc and welded rotors later. For clarity, stress corrosion did not affect monobloc or welded rotors in the Parsons 500 or 660 MW fleets, but it occurred in machines of other sizes and in other manufacturers turbines where prolonged wetness existed. This means that the choice of rotor – disc, welded or monobloc - did not provide protection against stress corrosion.

The measures taken – eliminating the keyway, reducing stresses, ensuring that only discs with good toughness values were used and periodic ultrasonic inspection proved to be successful and no further concerns arose regarding the 500 MW LP rotors.

(c) Steam chests

The first three 500 MW stations were built using the same steam chest designs as Thorpe Marsh and showed the same behaviour. By 1967, closed die forgings became available. These were considered to be superior to the open die forgings both in terms of strength and because the valve chambers could be made almost spherical or cylindrical in shape rather than “brick-shaped” ie the geometry could be much closer to ideal pressure vessel shapes. The HP steam chests for Rugeley B, Pembroke and Ince B followed the design shown in fig.174.

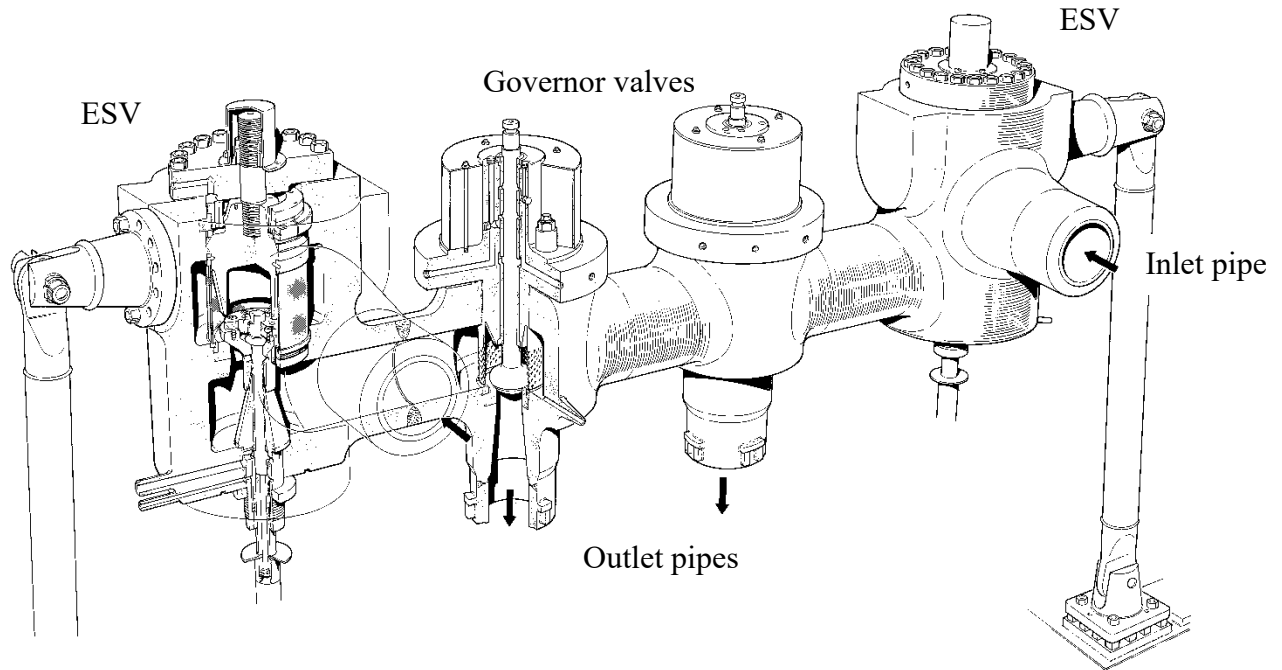

Fig.174 Later 500 MW HP steam chest. In the first few stations, the entire steam chest body was produced from a single piece forging. In subsequent machines, four separate forged valve chambers were welded together

In this design, the valve chambers were physically separated from each other, without the sudden changes in wall thickness of the earlier chests, with no internal ribs and lower stresses. They were designed for 200,000 running hours and achieved this. Chests generally operated for the entire life of the plant without needing replacement.

Experience with the 1 CrMoV steel introduced in the 1950s showed that the material properties were sensitive to cooling rate at the forgemaster with different strength levels in thick and thin sections. So, the steel was refined to improve its hardenability and reduce this sensitivity. Rather than increasing the alloy content, which would have affected its weldability, the alloy content was reduced and the revised steel ½ CrMoV was introduced in 1966. This proved to be very successful and was used until 1997.

The reheat steam chests remained the same as the Thorpe Marsh design ie a larger version of the chests used at Skelton Grange B. They employed an internal web connecting the floor to the ceiling of the upper chamber and they had a shared pressure wall between the lower chambers, fig.175. Both of these features suffered thermal fatigue cracks. In the last Heaton 500 MW station, Ince B, the upper web was eliminated by shaping the top chamber as a ‘figure eight’ in plan view to reduce the casing span, and the two lower chambers were separated so that there was no shared vertical wall. These stations were the last to use this chest style.

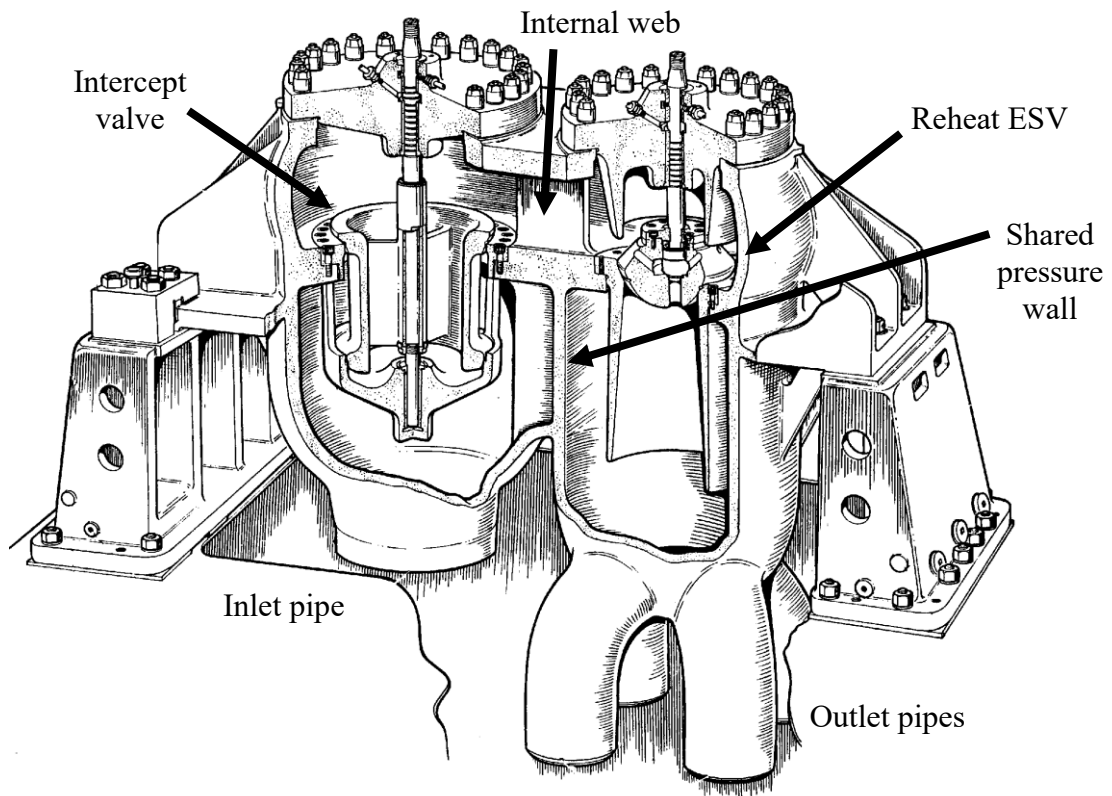

Fig.175 Original reheat steam chest used on the Heaton 500 MW turbines

(d) High temperature bolting

In the UK in the 1960s, the standard high temperature bolting materials were 1 CrMoV (Durehete 1055) and 1 CrMo (Durehete 900). For the 500 & 660 MW HP & IP inner casings, these materials were considered to be too weak and so a new material was introduced Nimonic 80A (Ni80A). This was a nickel-chromium superalloy which had been developed for use in gas turbines. The horizontal joint bolts of the inner casings were made from this. Since the creep strength of Ni80A was much higher than steel, it exhibited little relaxation in service and hence smaller bolts could be used tightened to a lower strain than steel to provide the required bolt force to seal. The retightening interval was initially 30,000 hours but this was later extended up to 100,000 hours.

When the bolts entered service, some failures occurred which passed into mythology within the industry ie misunderstanding caused some manufacturers to avoid using Ni80A. This was an unnecessary reaction.

The key points [22, 23, 24] may be summarised as follows:

- Within the whole UK steam turbine fleet (all manufacturers), a total of 74 bolt failures were reported from a family of approximately 14,000 bolts.
- This represented a failure rate of approximately 0.5%.
- Worldwide, five manufacturers were known to use Ni80A bolts on steam turbines.
- An overall failure rate of 0.37% was reported from experience across 231 machines.
- The causes of failure were attributed to stress corrosion cracking (47%), re-ordering / microstructural changes (47%) and 6% to other factors such as over-tightening.

The stress corrosion failures were linked to the use of molybdenum disulphide grease. This grease was subsequently banned and replaced with a more appropriate lubricant (typically graphite-based). This solved this issue.

Re-ordering (also known as reverse creep) was related to atomic movements within the crystal structure which cause bolts to shrink in size in service. As the bolts shrank, the strain increased by typically 0.03% to 0.08%. The maximum increase in strain was 0.11%. This occurred at temperatures below 538°C, with a maximum effect between 450 and 500°C. It wasn't significant above 538°C because normal creep processes caused the bolts to grow longer at higher temperatures and hence the bolt load relaxed. Reordering occurred when the bolts first entered service, and so, once the bolts had been loosened and retightened in subsequent maintenance outages, this effect was no longer significant.

The CEGB and UK manufacturers collaborated in a major study on bolting in the mid-1970s. It was from this work that most of the recommendations were developed which are known today as modern bolting practice. Changes which occurred as result of this work included:

- The use of relieved shank studs to reduce the stresses in the thread form.
- Avoidance of tight clearances in the thread form.
- Use of extension measurement to confirm the initial strain in high temperature fasteners.
- Revised lubricants.
- Increased insulation for external bolting.
- Reduction of the tightening strain for Ni80A bolts to 0.1%.

In other words, the bolts which failed were not tightened to modern practices and this was almost certainly a greater contribution to the root cause than re-ordering. Once these changes were made, there were no further reports of bolt failures. Parsons 500 and 660 MW turbines still operate with Ni80A bolts today.

(e) High temperature pipework

In the early 1960s, a 6% CrMoVWTi steel named Rex 500 was nominated as a material with promising creep rupture properties at 566°C. It was agreed with the CEGB that this material would be used for the HP and IP loop pipes of some of the 500 MW units including the first Parsons sets at Ferrybridge. Within a few weeks of service, steam leaks occurred from cracks in two welds [25].

It was possible to recreate the failures in the lab under slow strain rate conditions at stresses above 247 MPa. Forensics showed that cracks tended to initiate from existing sharp flaws near to the weld fusion line ie the flaws produced a stress intensity high enough to exceed the threshold for crack growth.

The weld metal was Inconel 182 (a NiCr superalloy) and it was found that the creep rupture strength at the interface between the NiCr and Rex 500 materials was only 65% of the strength of the parent or weld metal on their own. This had not been found during the original validation tests on full scale welds during the development phase, and was related to differences in the heat treatment conditions in welds made at site compared with factory welds.

As a short term fix, the weld metal was changed to 2¼ Cr 1 Mo but this also led to cracks. It was decided to remove the Rex 500 pipes and substitute ½ CrMoV pipes. This possibility had been allowed for in the design of the turbines because it was known that Rex 500 material was novel and might have to be replaced. The ½ CrMoV pipes operated well (apart from some type IV cracking) and this remained the standard material for Parsons loop pipes in subsequent years.

The reduced creep strength local to the weld was explained by the presence of narrow, soft layers typically only 30 to 100 microns wide. In the Inconel 182, these layers occurred at the fusion boundary, while in the 2¼ Cr 1 Mo, they formed within the weld metal itself.

In the 2¼ Cr 1 Mo welds, the softening was caused by the mismatch in the alloy content where certain alloying elements – especially titanium in the Rex 500 – would capture carbon in the form of stable carbides preferentially leaving a thin region denuded of carbide particles [26]. In the Inconel welds, carbide depletion was a factor but a greater influence was attributed to super-plasticity associated with a micro-duplex austenite/ferrite layer. In other words, small zones with either austenitic or ferritic structures were present where the size of each zone was typically smaller than 0.1 microns, fig.176 [26]. The mismatch between the coefficients of thermal expansion and other physical properties between austenite and ferrite generated high internal strains in the material which helped to initiate cracks.

The net outcome was that Rex 500 was not used again on the 500 or 660 MW fleets and a great deal was learned in terms of the tests which should be carried out when developing new pipe steels.

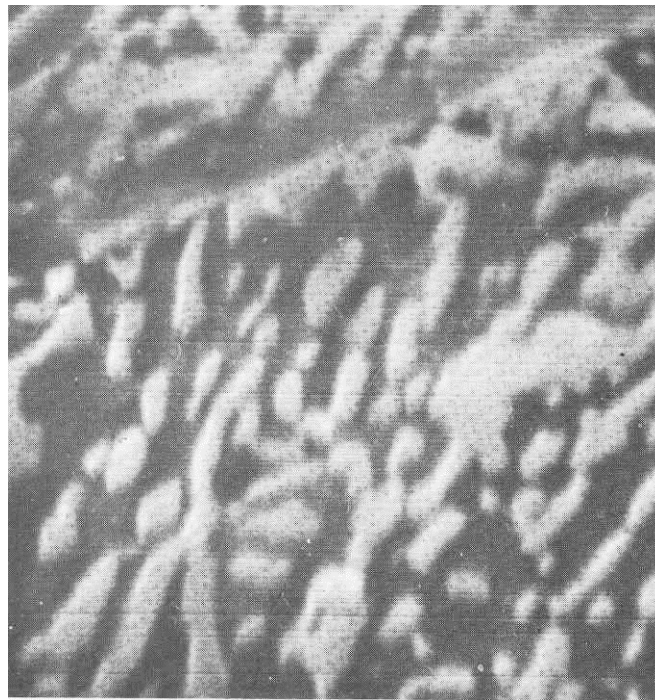

Fig.176 Micro-duplex region of austenitic and ferritic grains at the interface between Rex 500 and Inconel 182, x40,000

Parsons and GEC turbine technologies merge

During the 1950s and 60s, seven TG manufacturers had been active in the UK, as mentioned earlier. The CEGB had recognised that this provided some key benefits for them, specifically it stimulated competition between the manufacturers resulting in better products and lower prices, and it made it easier to promote the use of perceived best practices and emerging technologies across the UK industry [9, 27]. However, at the same time, there were some disadvantages too. For example, each manufacturer suffered different teething issues as their technology was pushed to ever larger power outputs and higher operating conditions. Every company or consortium came up with its own plant configuration. This was typified by the Magnox nuclear stations where every arrangement was different to the last. There was also a perception that design expertise was dispersed thinly amongst the manufacturers [27] when it might be better to concentrate the knowledge in only one or two companies. For these reasons, in 1965, the CEGB encouraged the TG manufacturers to merge.

GEC decided to withdraw from power generation in 1965 and its TG business which was based around a turbine factory at Erith in Kent and a generator factory in Witton near Birmingham were taken over by Parsons. This meant that all of their turbine and generator designs from 1901 to 1965 with all technical knowledge, design and manufacturing facilities became part of the CA Parsons family. The Erith and Witton factories continued operating for several years more up until around 1970 and then they were closed. Many people transferred to Heaton Works. One of these was John Mitchell, who had been Chief Engineer at GEC Erith and was appointed initially as Chief Turbine Engineer, subsequently Engineering Director, at Parsons.

The parent company GEC continued with its remaining businesses eg telecommunications etc. In practice, the company was re-structuring and decided to re-enter the turbine-generator market in 1967 by acquiring Associated Electrical Industries (AEI) which had been formed in 1928 by the merger of Metropolitan Vickers and British Thomson Houston, two major UK manufacturers. In 1968, English Electric was taken over also to form the ‘new GEC’. This left two major TG manufacturers in the UK: Parsons and the ‘new GEC’.

Since the TG businesses of the new GEC were unrelated and had no overlap with the old GEC, within the industry, it became commonplace to refer to ‘GEC Erith’ to describe the turbine technology which was now part of Parsons and ‘GEC Rugby’ as a shorthand to describe the new GEC business which had a major design centre in Rugby.

Focussing on GEC Erith, the company had built only impulse turbines but had designed units up to 660 MW at 3,000 revs/min. The machines over 100 MW which would be built either by GEC Erith or by CA Parsons using Erith technology are shown in table 5.

Station	No. of units	MW rating	Speed revs/min	HP stop valve pressure lbs/in ² gauge (barg)	HP / reheat temperature °F (°C)
Northfleet	6	120	3,000	1500 (103.4)	1000/1000 (538/538)
Kincardine B	2	200		2350 (162.0)	1050/1000 (566/538)
Tilbury B	4	350		2300 (158.6)	1050/1050 (566/566)
Didcot A	4	500			1000/1000 (538/538)
Kingsnorth	4	500			1050/1050 (566/566)
Dungeness B	2	660			1000/1000 (538/538)
Wallerawang	2	500			1000/1000 (538/538)

Table 5 Machines over 100 MW built using GEC Erith construction

The best available technology from GEC Erith at the time of the takeover was represented by Dungeness B, fig.177, which was partially designed but not yet constructed in 1965. This unit comprised a single flow HP turbine, double flow IP turbine and three double flow LP turbines with last stage blades which were initially 38” (965.2 mm) long with a tip diameter of 136” (3.45 m) although early operating experience with this blade at other stations caused tip failures and the blades were cropped to a length of 33.8” (858.5 mm) and a tip diameter of 127.6” (3.24 m).

Since fig.177 may be difficult to read at this scale, the HP , IP and LP1 turbines are shown individually in figs 178 to 180 respectively.

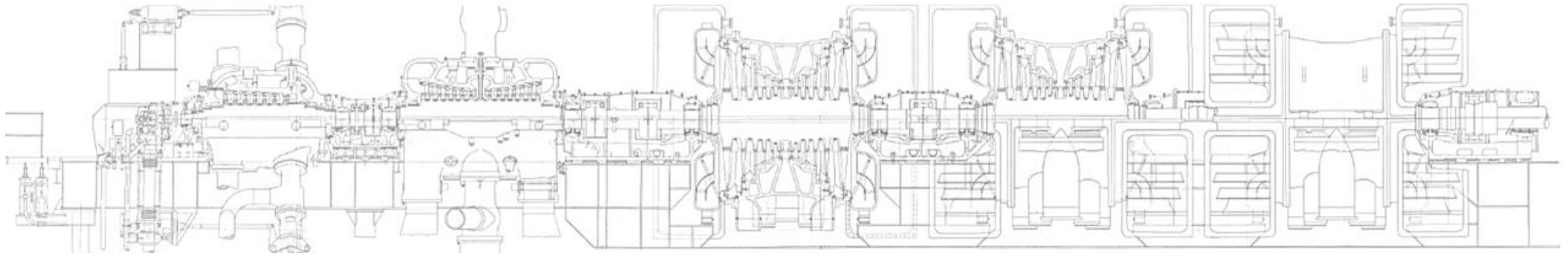

Fig.177 Dungeness B 660 MW 3,000 revs/min turbine 1965

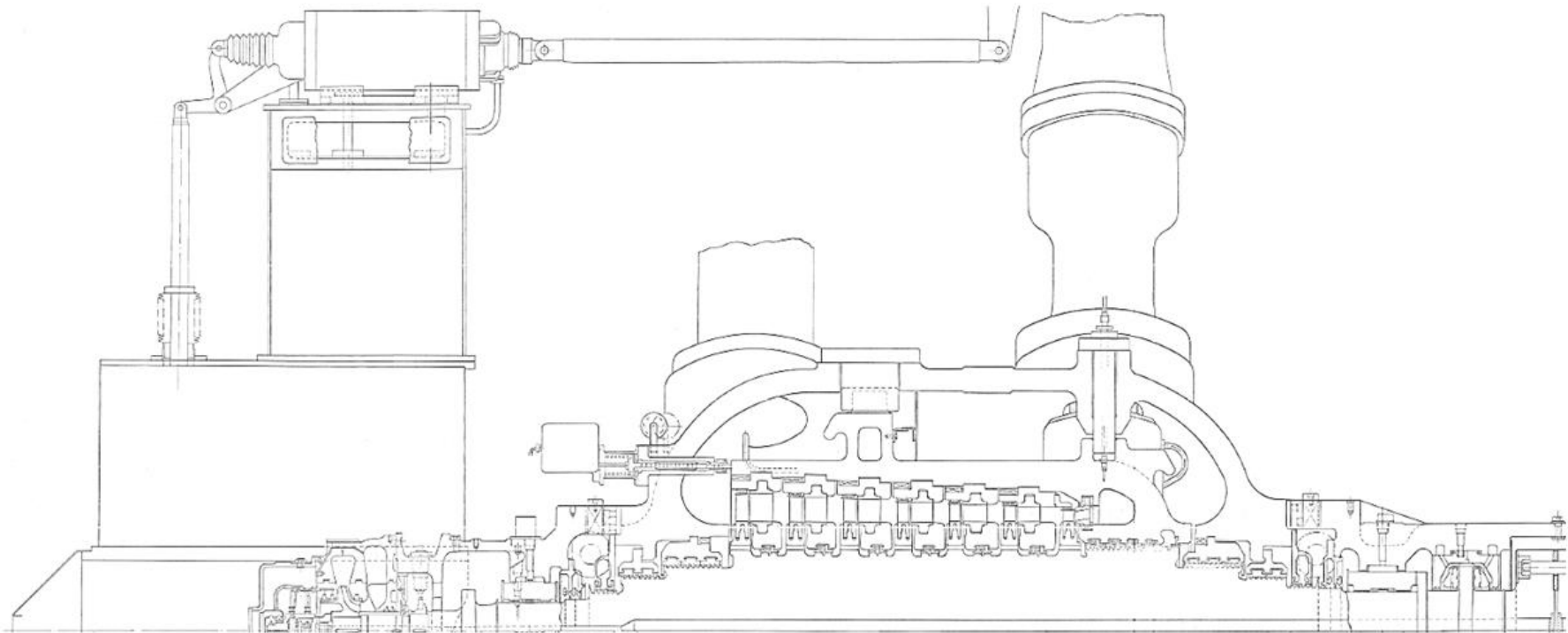

Fig.178 Dungeness B HP turbine

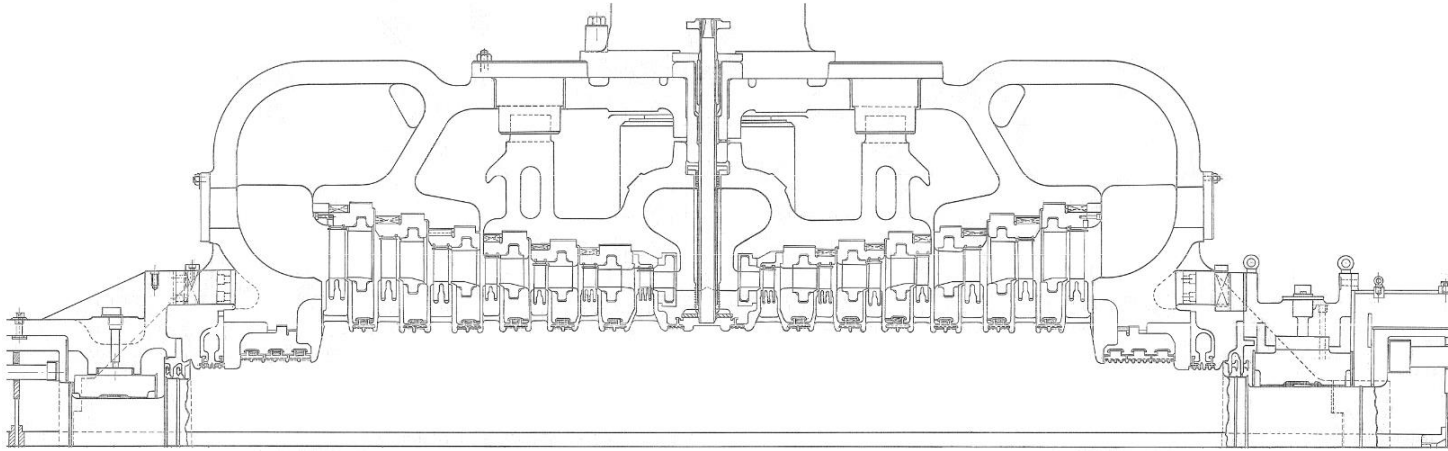

Fig.179 Dungeness B IP turbine

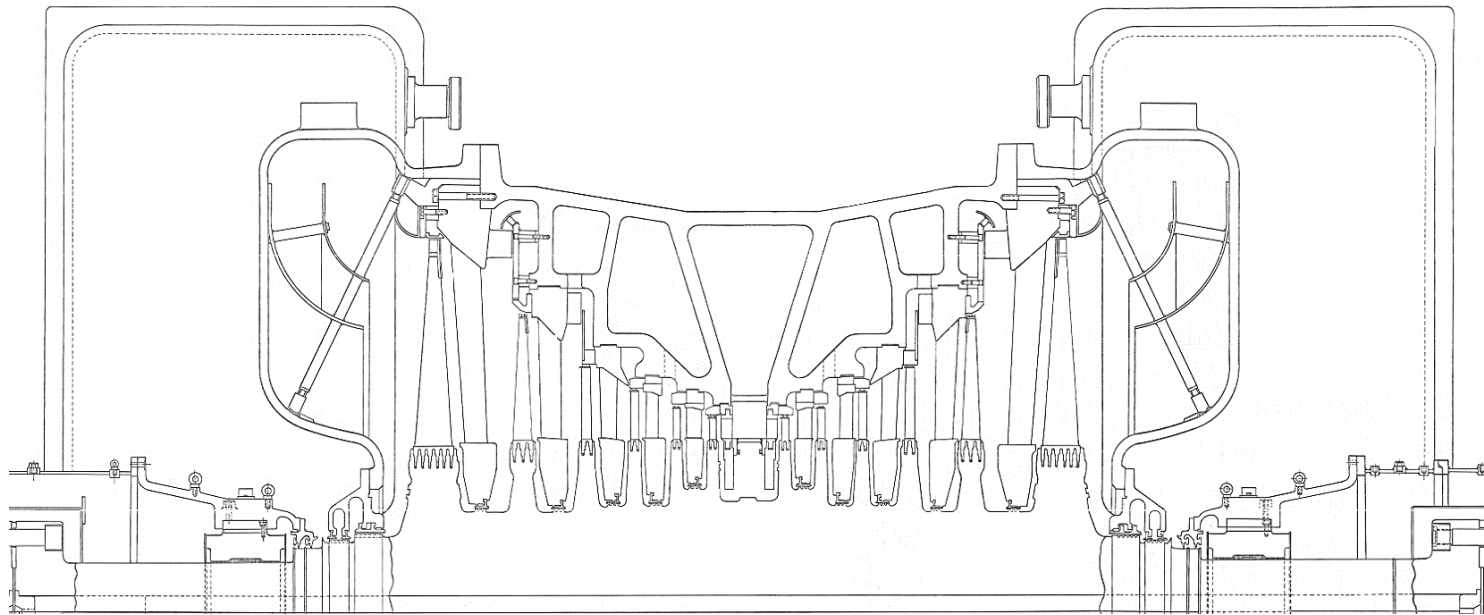

Fig.180 Dungeness B LP1 turbine

The design practice of the large GEC Erith turbines may be summarised as follows:

(a) HP & IP turbines

The HP & IP turbines used Rateau stages throughout the blade paths. The blades were mounted individually on pinned fork root fixings and employed riveted coverbands. The turbine rotors were made from 1 CrMoV monobloc forgings with small through-bores for inspection. HP turbine exhaust steam was injected underneath the IP turbine inlet flow guide to cool the IP rotor in the same way as Parsons turbines. The nozzle chests were cast integrally with the HP turbine inner casing. The inlet stage was throttle-governed. The turbine cylinders were fully double-cased.

(b) LP turbines

The LP turbine blades were also mounted on pinned fork root fixings and used riveted coverbands. The last stage moving blades employed inverted, arch coverbands in which the arch was designed to push outwards under centrifugal force during the run to speed, fig.193. This was expected to provide sufficient stiffness for vibration control, while incorporating some 'elasticity' to help cushion any transient stresses which might occur.

The LP turbine rotors were made from 2.75 CrMoV steel monobloc forgings. GEC Erith had adopted monobloc rotors for LP turbines earlier than Parsons, but the fracture toughness of the CrMoV forgings was lower than modern NiCrMoV steels. Consequently, the permitted crack sizes in some shafts were relatively small and the forging inclusion level had to be monitored carefully.

The Dungeness B 660 MW and Didcot A 500 MW turbines employed pannier condensers and so the LP turbine cylinders were single-cased. Otherwise, large GEC Erith LP turbines were double cased.

(c) HP steam chests

The HP turbine valves on Dungeness B comprised four HP ESVs, fig.181a, mounted in front of the turbine-generator foundation block and four throttle valves, fig.181b, mounted directly on the turbine inlets. The throttle valve relay depended upon a mechanical linkage to the governor in the no.1 bearing pedestal, fig.178.

The HP ESV was an 'inverted valve' ie the valve stem was downstream from the valve seat. Parsons adopted this design for subsequent ESVs from 1967 until 1984, as shown in fig.174, which is a typical example. This gave the advantage that the main steam pipes upstream from the valves could be pressurised before the condenser was entirely ready to take steam. In previous Parsons machines, pressurising the pipes allowed steam to enter the valve glands and hence reached the condenser. The condenser pressure could then exceed atmospheric opening the pressure relief devices (LP turbine lifting diaphragms) if the condenser wasn't ready. The Erith valve covers were sealed using a triangular metal seal ring known as a 'Bridgman joint'. This seal was used on many Parsons ESVs until 1980. Otherwise, the remaining aspects of the GEC Erith HP valves were not used. Placing the ESVs in front of the foundations increased the amount of pipework and the pressure losses which would have counted as part of Parsons scope of supply. This also would have increased the amount of steam trapped downstream of the valves after trip which could contribute to a transient overspeed. Mounting the throttle valves on the HP turbine casing seemed to be a good idea because it eliminated the cost and pressure losses of some of the loop pipes. However, it increased the electricity generation revenue which the power station lost due to increased machine downtime when the top valves and linkages had to be dismantled to open the HP turbine for maintenance. These features were considered to be undesirable and so were discontinued.

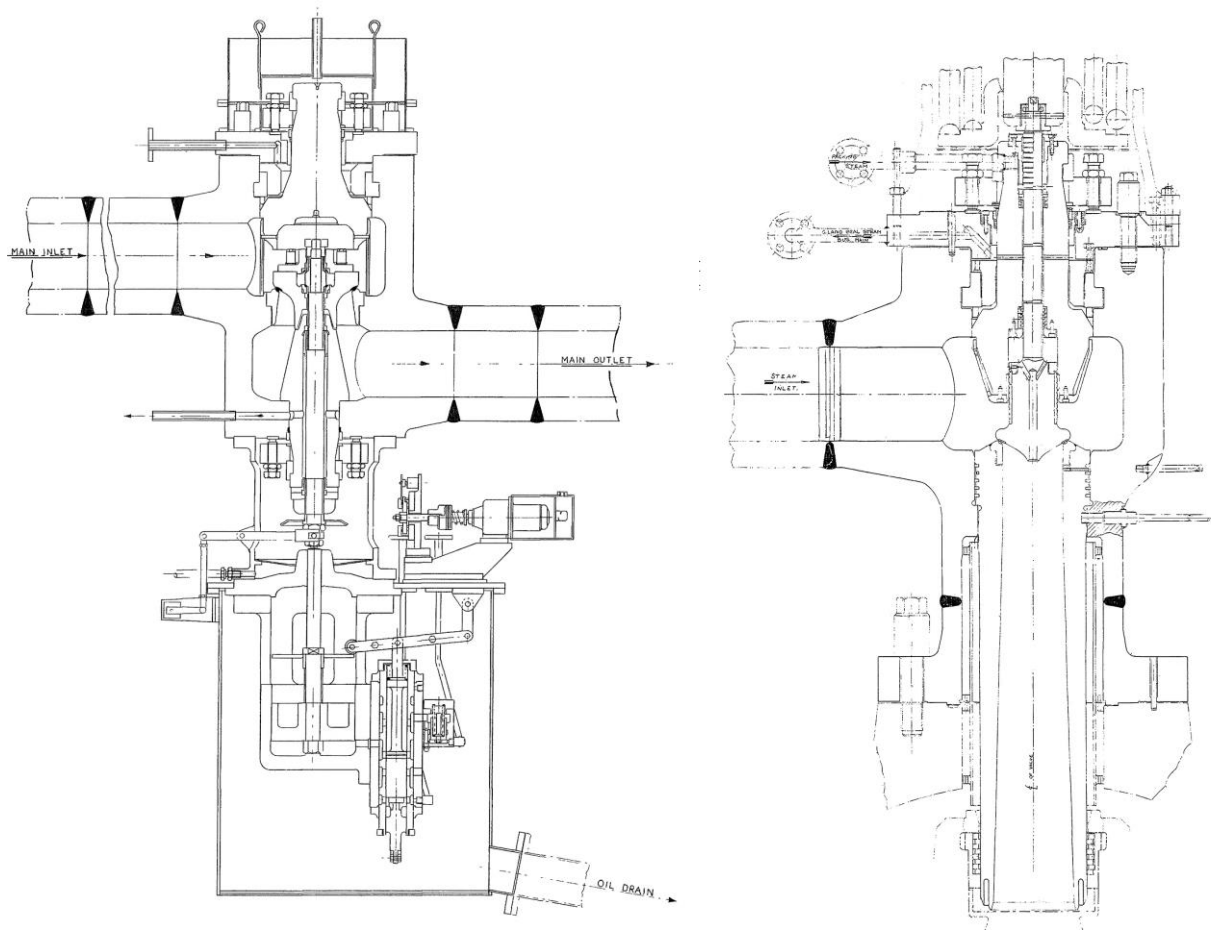

Fig.181a Dungeness B HP emergency stop valve, *left*, and fig.181b top inlet throttle valve, *right*

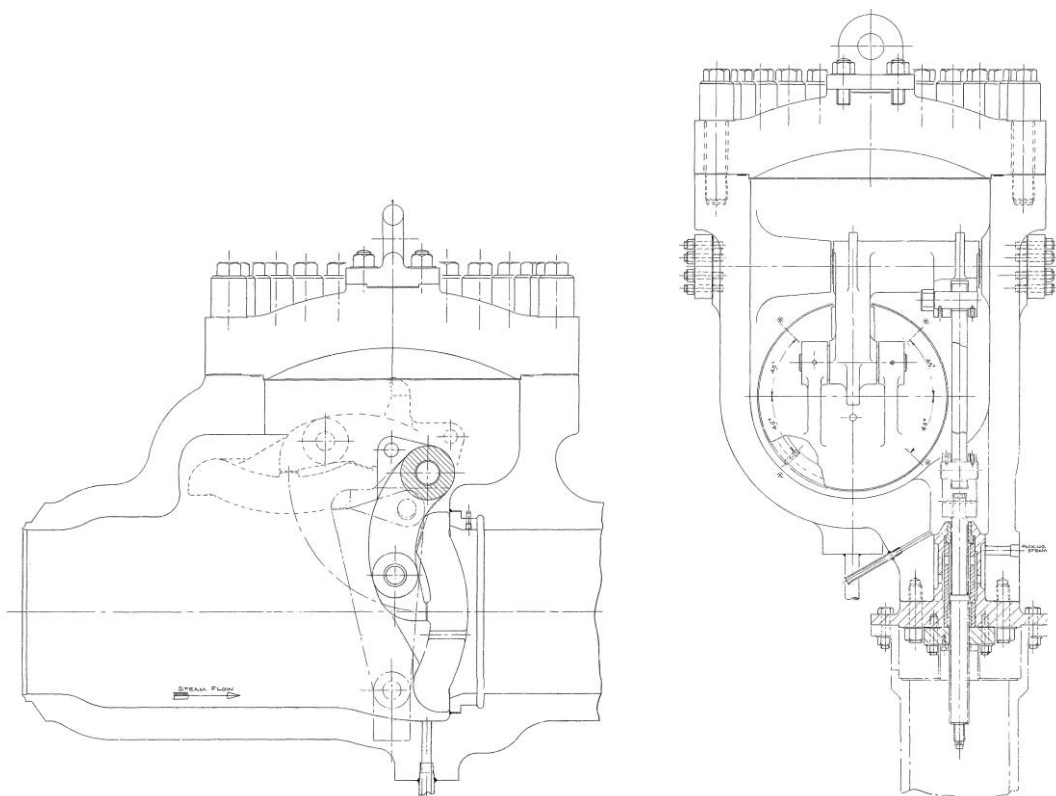

Fig.182 Dungeness B Reheat emergency stop valve, side view *left* and end view *right*

(d) Reheat steam chests

The IP turbine valves on Dungeness B comprised four flap type reheat ESVs, fig.182, plus four plug type valves (similar in nature to the HP throttle valves) mounted directly on the IP turbine inlets. These designs were not adopted by Parsons. Instead, a completely new reheat steam chest was developed which is described in the next section.

Heaton 660 MW 3,000 revs/min units

The first turbines to be designed after the technologies of Parsons and GEC Erith merged were the 660 MW units for Drax and Hunterston B power stations in 1967. Drax employed six units installed in two phases and for many years was Europe's largest coal-fired power plant as well as the largest power station in the UK. Hunterston B was a nuclear power station with advanced gas-cooled reactors (AGR) providing steam to two TG units.

The key issue was 'which type of blading should be used in each cylinder?' Based upon the available information, it was decided that the HP turbine should use a Rateau inlet stage to reduce the steam pressure and temperature followed by reaction blading. This was chosen for the inherent high efficiency of reaction stages, plus it avoided the need for massive HP diaphragms [32]. The HP bladepath therefore resembled Ferrybridge C. Impulse blading was chosen for the IP and LP turbines as they allowed the use of Erith blading with clean aerofoils (no lacing wires) and were expected to perform well. These cylinders were similar to Dungeness B.

The last stage blades were Parsons design using the Erith inverted arch coverband with a length of 36" (914.4 mm) mounted on a base diameter of 64" (1.63 m) to give a tip diameter of 136" (3.45 m). Structurally, the units could have been built with four exhaust flows, but six flows were chosen instead to achieve low leaving losses. The average velocity leaving the last stage blades was Mach 0.5, much lower than the value for Dungeness B which was Mach 0.75. Pannier condensers were used.

Fig.183 shows a cross-section through the Drax turbine line and fig.184 shows Drax Unit 1 being assembled at Heaton Works. Fig.185 shows the six units installed at Drax. This was the only power station in the UK to have the TG sets installed at an angle relative to the turbine hall to save space.

Parsons built 660 MW sets for coal, oil and AGR nuclear applications. The respective steam conditions were as follows:

Coal-fired units	2300 lbs/in ² gauge 1050°F HP / 1050°F reheat (158.6 barg 566°C / 566°C)
Oil fired units	2300 lbs/in ² gauge 1000°F HP / 1000°F reheat (158.6 barg 538°C / 538°C)
AGR nuclear units	2300 lbs/in ² gauge 1000°F HP / 1000°F reheat (158.6 barg 538°C / 538°C)

In addition, the coal-fired units employed 8 stages of feedheating, the oil-fired units used 4 stages and the nuclear sets had 5 stages. The steam flow rates and internal conditions were therefore slightly different in each machine type, but the rotors were designed to be interchangeable. This allowed National Spare rotor trains to be held for the fleet.

The CEBG specified a design life of 200,000 running hours plus 5,000 major load cycles, 4,000 hot starts, 1,000 warm starts and 200 cold starts for new turbines starting with Drax. This became the standard design life for all new Parsons turbines.

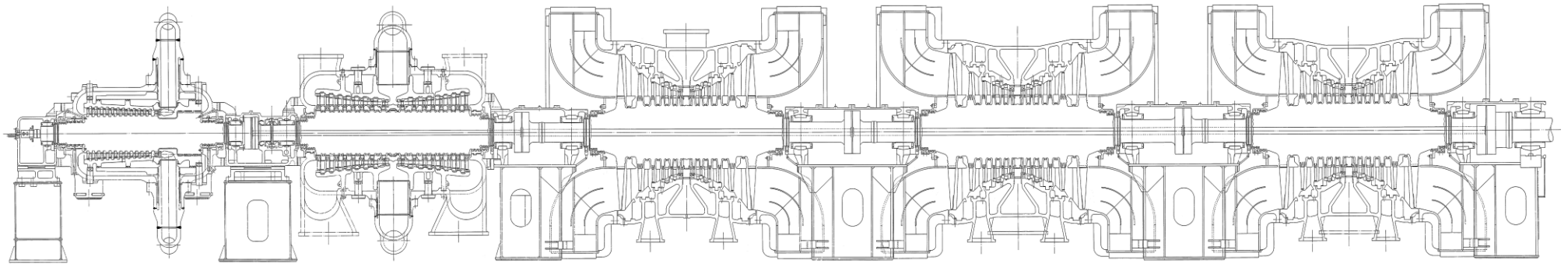

Fig.183 Drax 660 MW 3,000 revs/min turbine 1967

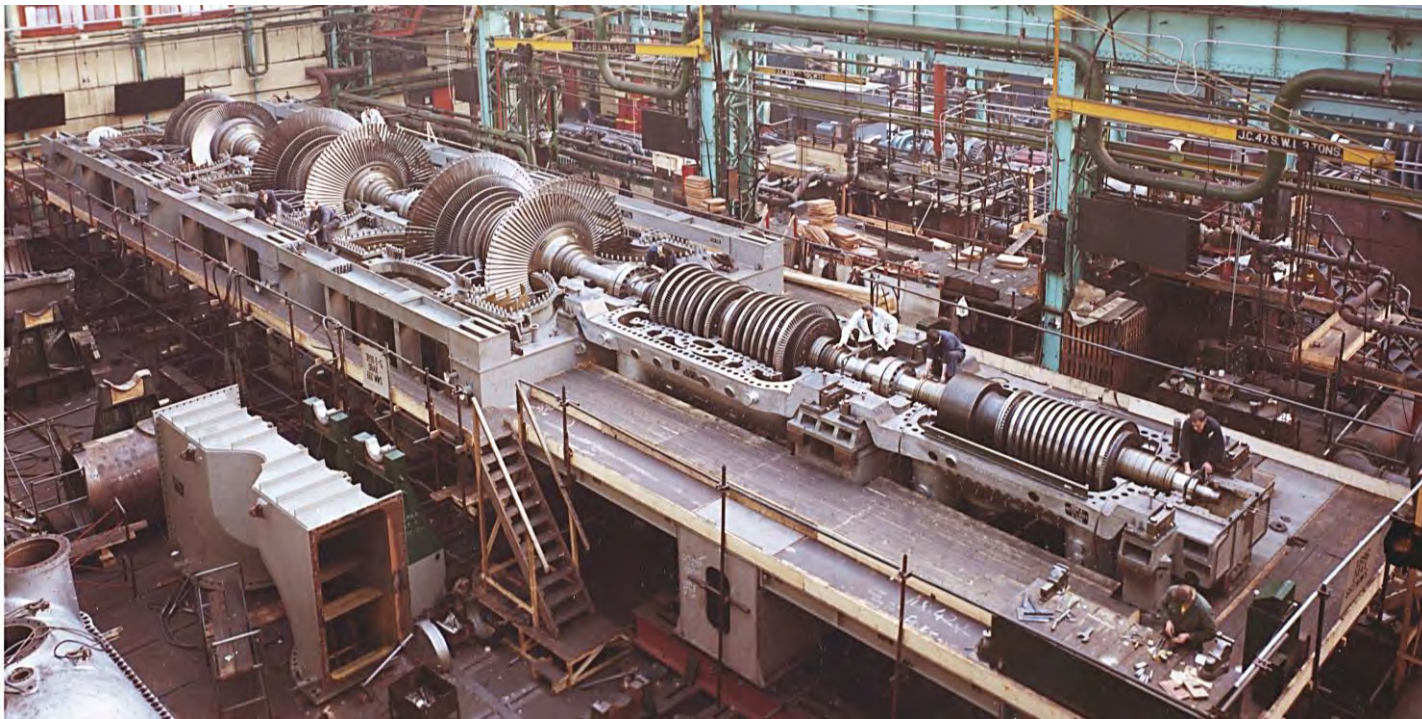

Fig.184 Drax Unit 1 turbine during assembly in Heaton Works Erecting Bays



Fig.185 Six 660 MW TG sets installed in Drax

Let's look more closely at the HP, IP and LP turbine designs.

(a) HP turbine

The HP turbine, fig.186, employed a Rateau stage to reduce the steam conditions to 1800 lbs/in² abs 981°F (124.1 bara 527°C). This benefited the strength of the ½ CrMoV casings and 1 CrMoV rotor.

The reaction blades were 600 series type. They performed well, but the aerofoils had to be reinforced to withstand the steam forces. In previous years, an option had been provided to add extra material tapered over 50% of the blade height closest to the root fixing to increase the bending modulus of the base section of the aerofoil by 70%. This was used.

The first turbine rotors were bored monobloc designs. By the late 1970s, when more advanced ultrasonic inspection methods were available, unbored shafts were used which reduced the stresses close to the centreline of the shafts.

To establish a reference design for potential future supercritical turbines (ie turbines operating with steam pressures higher than 3200 lbs/in² abs), Parsons decided to include a ‘barrel’ casing ie a casing without a horizontal joint, figs.186 and 187.

The middle casing was an unsplit barrel design (ie it had no horizontal joint) allowing the machine to carry much higher pressures in any future super-critical applications

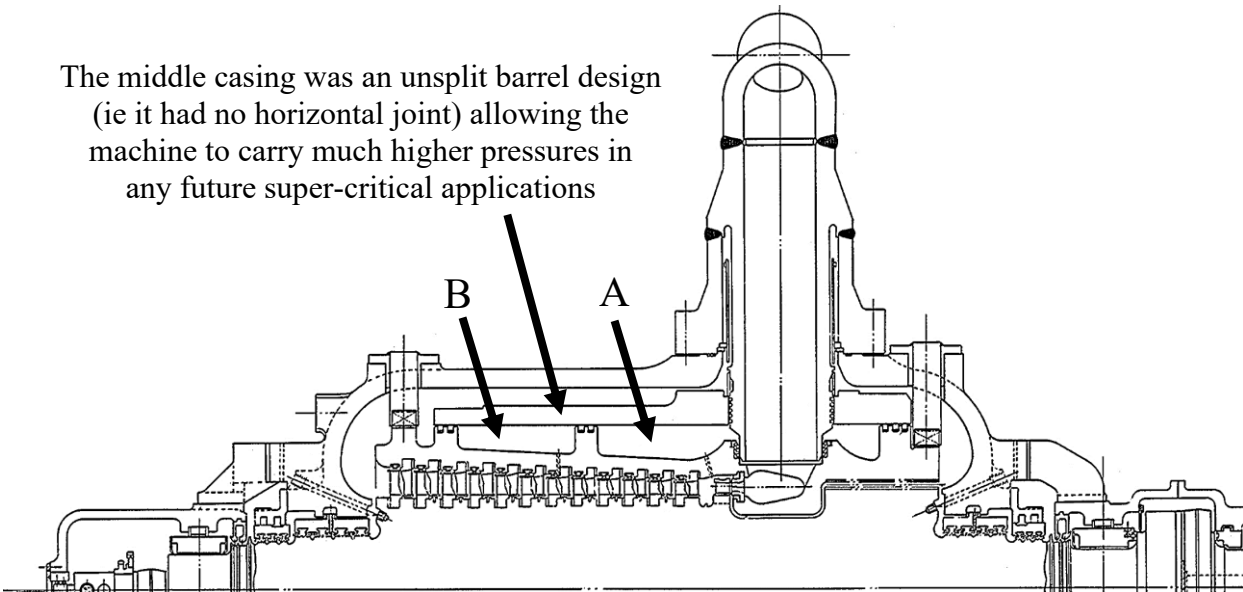

Fig.186 Drax HP turbine



Fig.187 Drax HP turbine barrel or middle casing

Inside the barrel, a separate inner casing was needed to carry the fixed blade rows. Since these blades interleaved with the moving blades on the shaft, the innermost casing had to have a horizontal joint so it could be assembled around the rotor. For maintenance, the barrel casing, inner casing and rotor had to be lifted away from the machine and placed on special supports with a trolley to slide the barrel section off horizontally. Ideally, the barrel and the inner casing should have been the only casings that were needed. However, in 1967, any attempt to lift these casings away for disassembly would have lost the alignment of the machine. Methods did not exist yet to

allow an entire HP turbine to be removed and later replaced with precise accuracy. Consequently, the whole machine would have had to have been realigned from scratch according to the natural curvature or ‘catenary’ of the rotor train, starting with the LP turbines which formed the datum of the catenary. To avoid this, an HP turbine outer casing with a horizontal joint was provided which remained in place to maintain the accurate alignment of the turbine line while the HP rotor, barrel & inner casing were lifted out. The outer casing had four exhaust pipes – two at each end – to allow the barrel casing to be cooled uniformly in service.

The inner casing formed two compartments inside the barrel, marked A and B in fig.186. Vent holes pressurised these compartments with steam from after the Rateau stage and the stage 6 fixed blades respectively. This created pressures surrounding the inner casing which were higher than the pressures inside the local bladepath. This had the effect of partially clamping the inner casing closed in service and so helped to reduce the size of the bolted flanges needed on the inner casing. Also, the inner casing bolts were made from Nimonic 80A material as mentioned earlier to help reduce their size. Compartment A had vent holes adjacent to the upstream side of the rotor balance piston. This ensured that cool steam from the outlet of the Rateau stage surrounded the balance piston and enabled the pressure acting on the piston to be accurately controlled to produce the desired rotor end thrust.

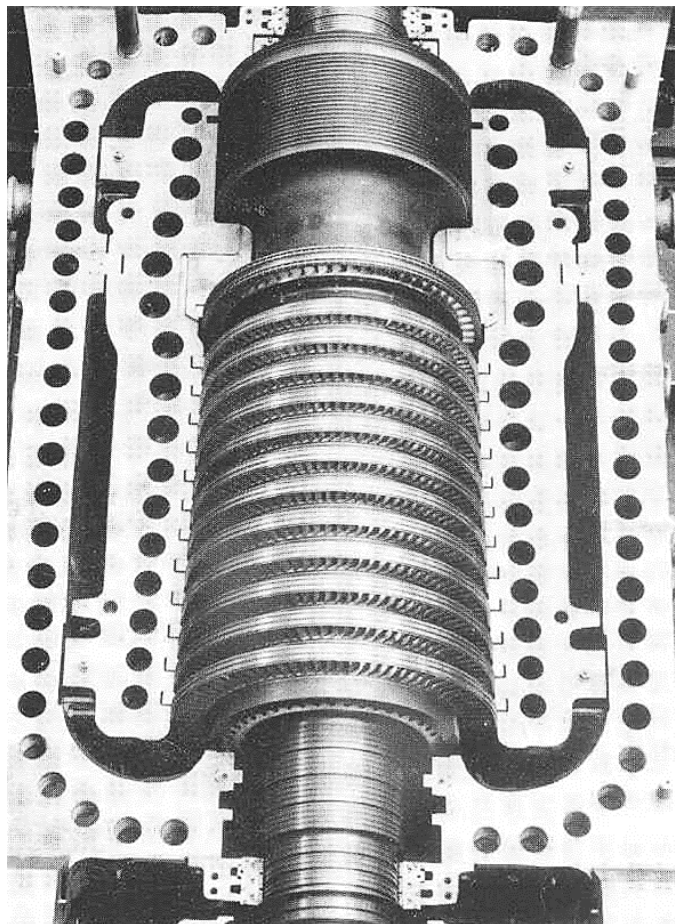

Fig.188 Hunterston B HP turbine with conventionally split inner and outer casings and integrally cast nozzle chambers

For Hunterston B, a conventional, horizontally split, twin shell HP casing was used with integrally cast nozzle chambers, fig.188.

(b) IP turbine

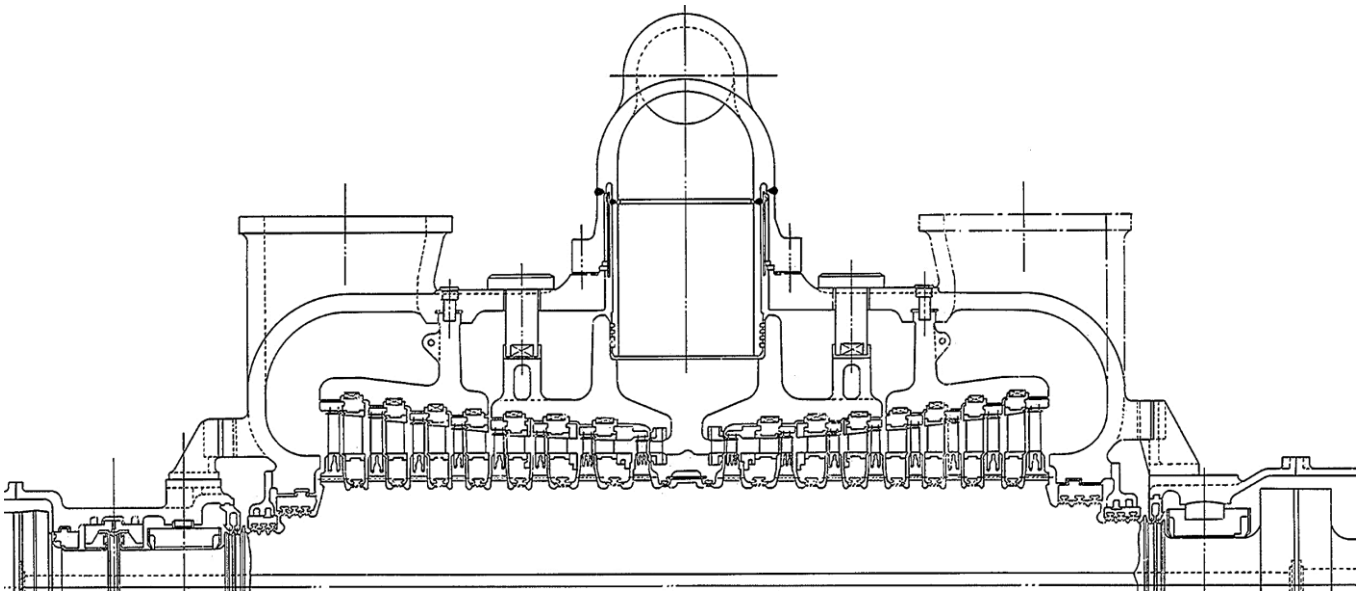

Fig.189 Drax IP turbine

By 1967, both Parsons and GEC Erith had reached the conclusion that a completely double-cased IP turbine was the best design to minimise stresses and deflections. The rotor was a 1 CrMoV monobloc forging cooled by injecting a small amount of HP turbine exhaust steam beneath the inlet flow guide, as on previous machines.

The IP turbine operated reasonably well with a cylinder efficiency of around 91%. Once the machines were in service and this could be measured, it was realised that 50% reaction blading would have achieved a higher performance.

(c) LP turbines

Fig.190 shows a cross-section through the Drax LP1 turbine.

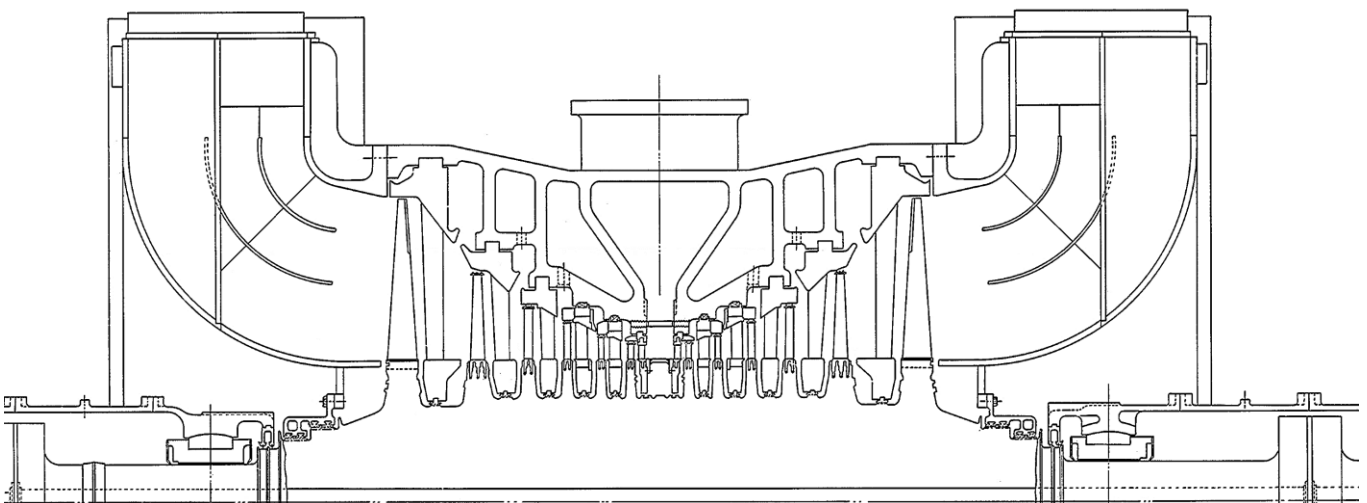

Fig.190 Drax LP1 turbine

The Drax LP turbines were similar to Dungeness B, but there were some key differences. For example, the LP rotors were made from 3.5 NiCrMoV steel for higher fracture toughness and increased strength. Most of the LP shafts were monobloc forgings. However, since another manufacturer claimed that shafts made from several discs welded together might be more cost effective than a monobloc forging, Parsons decided to install six 660 MW welded rotors, fig.191. Similar rotors were made for GEC Erith 500 MW units. The manufacturing costs proved to be higher than monobloc designs, so the claims were not substantiated. In addition, the welded shafts tended to respond more strongly to rubs due to the lower thermal inertia of the rotor body.

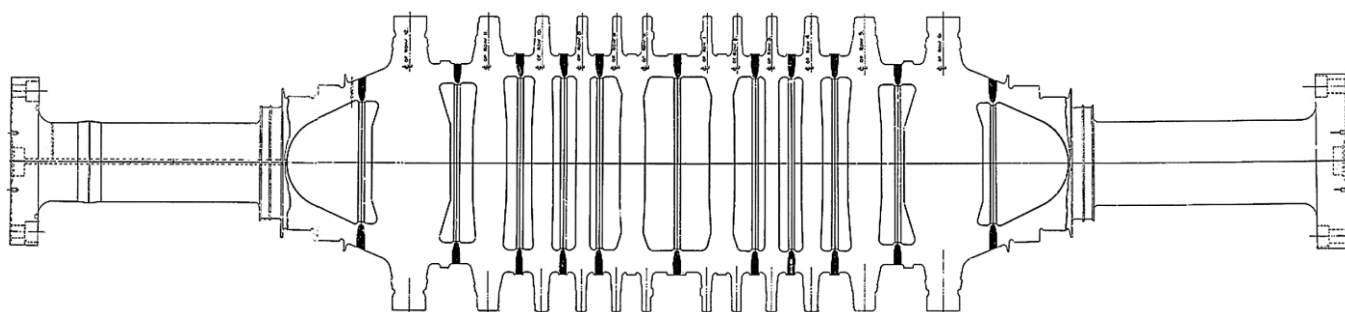

Fig.191 Drax welded LP rotor

In the bladepath, it was GEC Erith practice to fasten the root fixing pins by hot riveting. This produced a thin zone of transformed material around each hole in the outermost rotor fingers, fig.192a and b. The heat affected zone was hard and brittle producing small cracks in service which grew by stress corrosion. If left alone, radial and circumferential cracks extended from hole-to-hole and from hole-to-wheel rim like a spider's web. Since this affected only the outermost fingers, the surface was skimmed to remove the damaged material. From 1973 onwards, only cold riveting was used and the problem never returned.

Once cold riveting was adopted, pinned fork root fixings in Parsons machines proved to be completely resistant to stress corrosion. For this reason, Parsons employed pinned fork roots for all subsequent L-1 and L-2 stage blades.

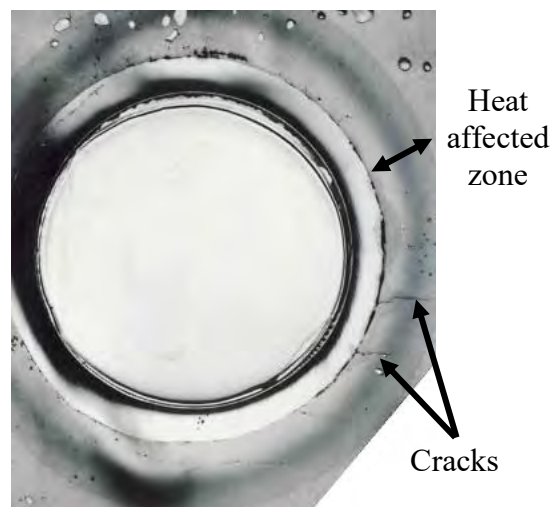
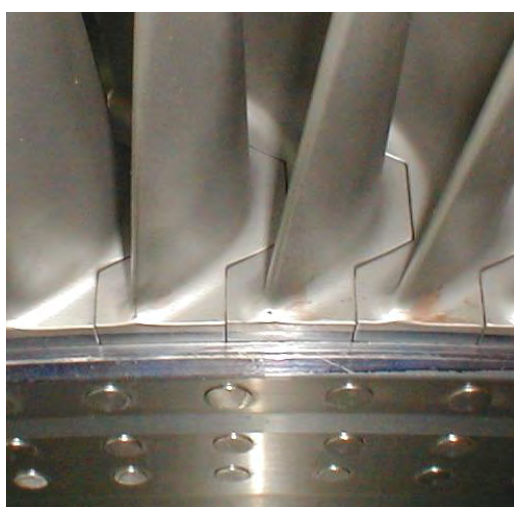

Fig.192a Typical Erith L-1 stage root fixing, *left*, and fig.192b the heat affected zone and cracks which formed around a root pin which had been hot riveted, *right*

Another GEC Erith practice was the use of rectangular or trapezoidal tenons to attach the coverbands, fig.193a and b. The tenons required holes of a matching shape in the shroud, which could not be machined and so had to be formed by punching. The sharp corners of the holes formed stress raisers and the punching operation left adverse residual stresses and this led to cracks.

The L-1 coverband suffered the most because it used three tenons per blade not two and one or more of these tenons often fractured. Pull tests were carried out in a test rig and it was found that only two out of three tenons carried the CF pull of the coverband at any given time which explained why they were becoming overloaded.

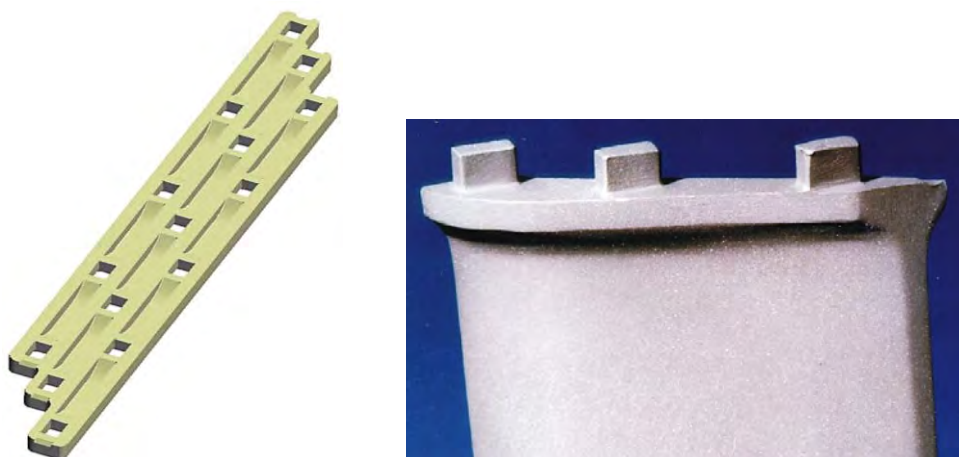

Fig.193a Erith L-1 stage coverband with three tenon holes, *left*, and fig.193b the corresponding blade tenons, *right*

These issues were solved by redesigning the L-1 and L-2 stage blade tips so that no more than two tenons were used. The tenons were designed to have an obround shape, fig.194, which could be produced by CNC machining (no punching), there were no sharp corners and the tenon shape had a substantial cross-sectional area.



Fig.194 Revised coverband with obround tenons

The L-0 blade used a GEC Erith inverted arch coverband, fig. 195. This design was problematical for two reasons. Firstly, L-0 blades untwisted by around 5° as the machine ran up to full speed (a greater angle during an overspeed test) which the coverband tried to resist. Secondly, when there was any variability in the distance between adjacent blade tips, it was important that shims were fitted to adjust any gaps. In the 1960s and 70s, blade fitters were tempted to pull each blade across while the arches were being fitted instead of using shims. When the blades were released afterwards, locked-up stresses existed in the blade row.

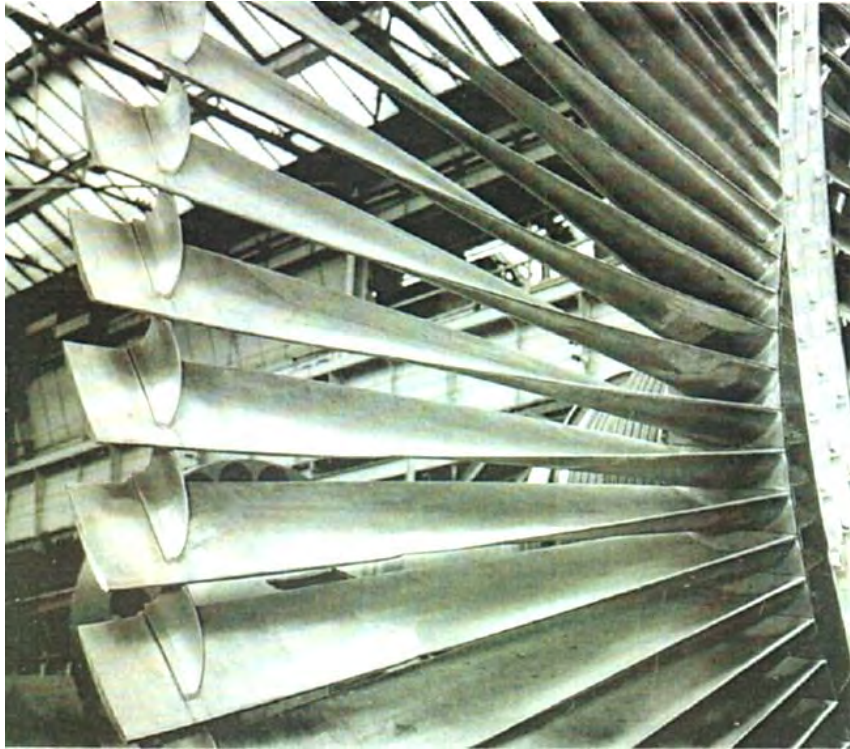

Fig.195 Drax last stage LP blades with inverted arch coverbands

By 1980, it was concluded that arched coverbands were fairly well suited for blades up to 30” long with a tip diameter of 120” at 3,000 revs/min (762 mm long, 3.05 m diameter) but they were not a good choice for the 660 MW blades which were 36” long with a tip diameter of 136” (914 mm long, 3.45 m diameter). Consequently, when new blades were designed using CFD techniques, this feature was discontinued.

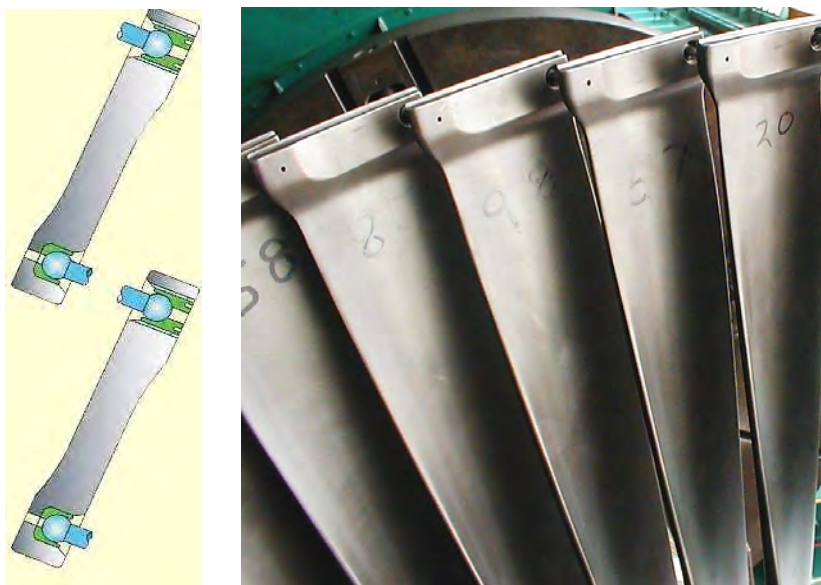

Fig.196 Parsons articulating tip strut

Instead, a new tip tie was developed called the “articulating tip strut”, fig.196. This design had a ball-ended strut which sat in spherical seats and allowed the blades to untwist freely. It was different to other manufacturers’ tip struts because one of the spherical seats had a screw thread which was

used to pre-load the struts and so pre-twisted the blades into their normal running position while the machine was at rest. This meant that there was some locked-up stress while the machine was stationary but as the blades ran up to speed, the normal untwisting action relieved the stress. This meant that the blade tip section experienced low stresses under normal running conditions. A nominal force remained to assist damping and keep the blades in contact with each other. The tip block provided reinforcement so that the holes passing through the blades didn't create any significant stress raising effects. The tip strut was highly successful and was used for all new last stage LP blades developed by Parsons from 1982 until the company joined Siemens in 1997.

(d) Steam chests

The 660 MW sets used the type of HP steam chest shown in fig.174 with separate, closed die forged valve chambers welded together.

A new reheat steam chest was developed as shown in fig.197. This was constructed from castings welded together. It created valve chambers which were physically separate from each other shaped from near ideal (ie almost spherical) pressure vessel shapes. There were no internal webs or shared pressure walls which had been troublesome in earlier designs. Large diffusers were formed immediately downstream from the intercept valves to recover pressure losses.

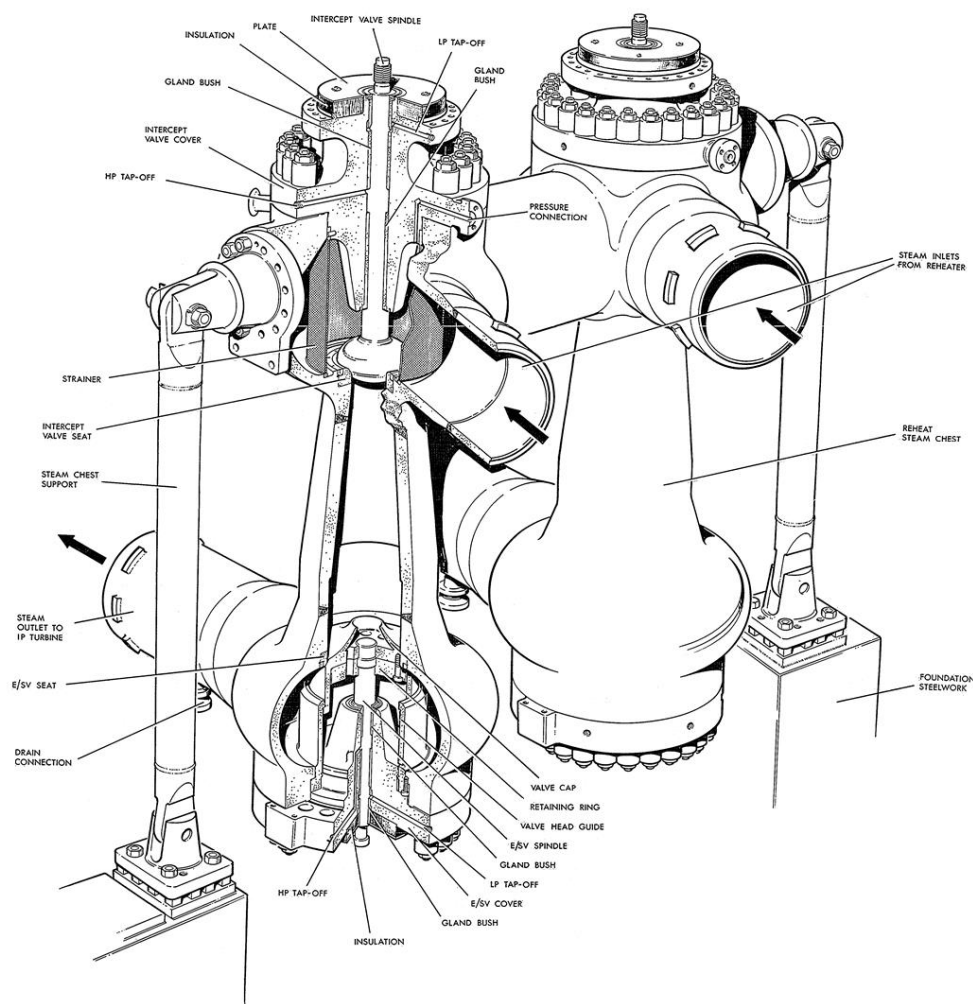
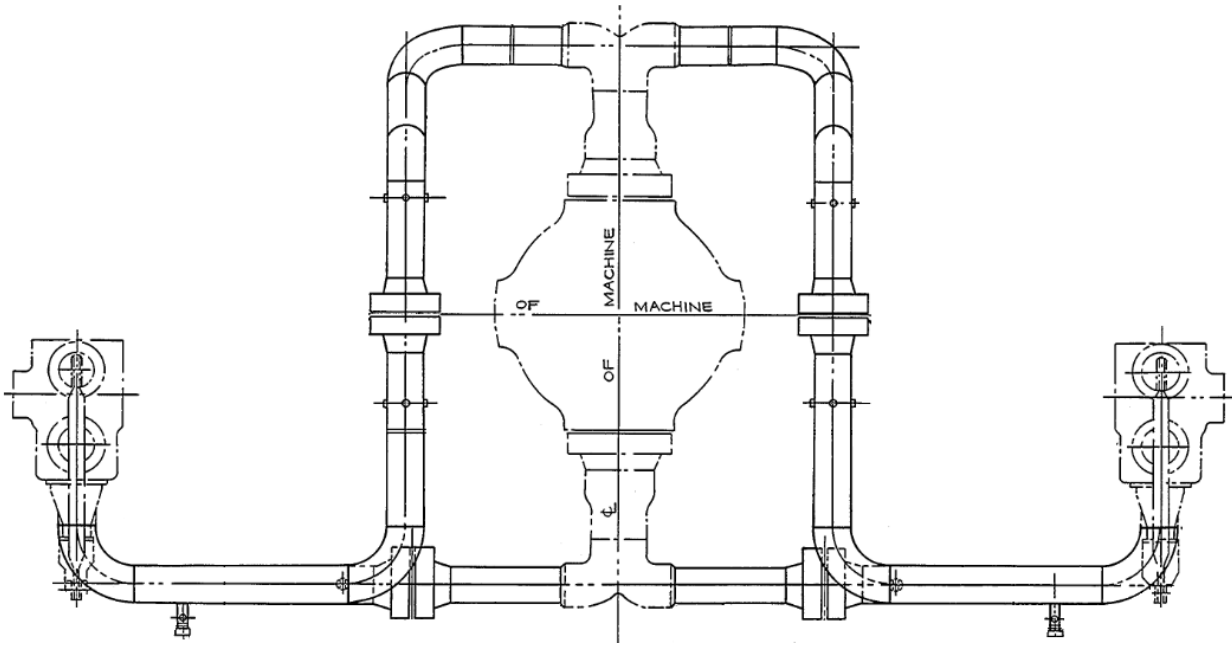

Fig.197 Reheat steam chest employed on 660 MW turbines (two per machine ie 8 valves in total)

(e) Loop pipes

Compared with the Thorpe Marsh loop pipes, fig.157, the pipe arrangement on Drax was greatly simplified, fig.198. This was achieved by using gimbal supports for the steam chests which allowed some additional freedom of movement in service.



a End view of HP turbine loop pipes

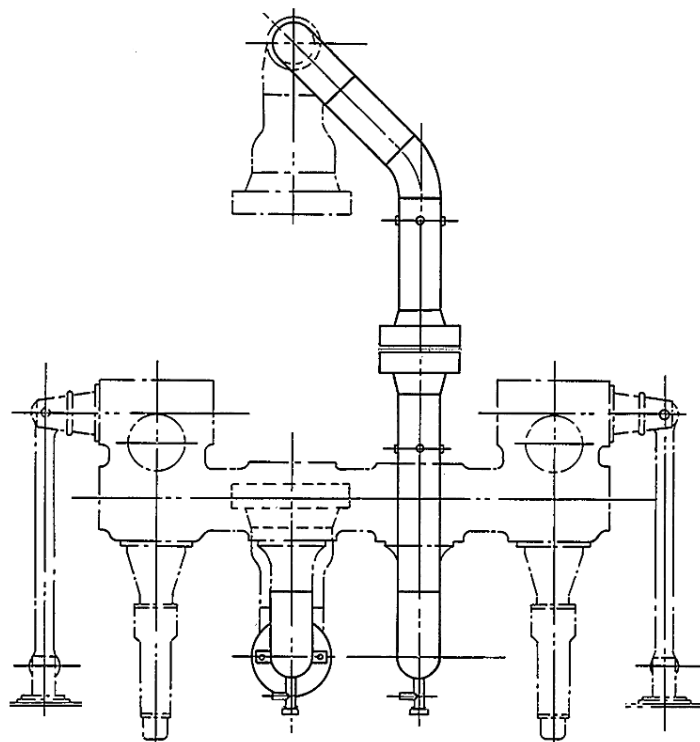

b Side view of HP turbine loop pipes

Fig.198 Drax loop pipes joining the two HP steam chests to the HP turbine outer casing

CANDU Wet steam nuclear turbines 540 to 800 MW 1,800 revs/min

Work on developing effective nuclear reactors commenced in Canada during World War II. By the early 1950s, work was sufficiently advanced to start designing reactors for large scale power generation. In 1955, the CANDU (Canadian Deuterium Uranium) reactor was chosen as the basis for electrical generating stations since this allowed unprocessed natural uranium to be used as the fuel, which was readily available in Canada. This type of reactor used heavy water for both the moderator and coolant and produced steam at around 40 bar gauge saturated. The first application was built at Rolphton and was named the Nuclear Power Demonstration (NPD) plant. It produced 20 MW of electricity and was commissioned in 1962 [28]. The next plant was located at Douglas Point on Lake Huron and produced 200 MW starting operation in 1967 [29].

Ontario Hydro and Atomic Energy of Canada Ltd (AECL) committed to build the first commercially competitive plant at Pickering in 1964 with orders for the turbine-generators being placed with Parsons in 1965. This station was located on the north shore of Lake Ontario 20 miles from Toronto and it employed eight 540 MW units installed in two phases. When the first four units were all in service in 1973, Pickering was the largest nuclear power plant in the World. An order for four units of 800 MW for Bruce A power station followed in 1969. These were the most powerful TG sets which Parsons built.

Parsons worked closely with Ontario Hydro and AECL to ensure that CANDU stations were as effective as possible. After the multi-unit stations Pickering and Bruce, reactors were developed for power stations with one 680 MW TG unit for export. Parsons supplied turbines for two of these stations in Canada and South Korea. In total, 14 Parsons CANDU TG sets were installed worldwide (approximately one third of all CANDU units) and these regularly held the record for nuclear power plants of any type with the highest capacity (utilization) factors throughout the 1970s and 80s.

Pickering HP stop valve conditions were 585 lbs/in² gauge 485°F (40.3 barg 252°C). These values were similar to those of the Crawford Avenue 50 MW unit of 1922 except that the machine rating was more than 10 times larger. Bruce conditions were slightly higher at 600 lbs/in² gauge 489°F (41.4 barg 254°C) but at 800 MW, the rating was 16 times larger. So one of the main challenges was how to design turbines of considerable size which ran continuously with wet steam. Compared with a 500 MW fossil-fired unit of the mid-1960s, the steam flow rates in Pickering and Bruce were much higher because (a) the power outputs were higher, (b) there was less available energy per kg of steam due to the lower stop valve conditions, (c) the conversion of steam into water inside the blade path reduced the mass flow rate which actually produced power and (d) the water caused some power losses inside the blading. The CANDU turbines not only needed higher mass flow rates (kg/sec), but the lower operating pressures also increased the volumetric flow rates (m³/sec) compared with fossil-fired plant. Table 6 shows a comparison between the relative mass and volumetric flow rates of Pickering and Bruce turbines against a typical, contemporary Parsons 500 MW fossil-fired machine. It can be seen that Pickering and Bruce required 2 and 3 times the mass flow rate respectively compared with the fossil-fired unit, but more importantly, the volumetric flow rates were 5 and 7.4 times greater respectively for the CANDU turbines. The very high flow rates dictated that the turbines should use a double flow HP turbine plus three double flow LP turbines, figs.199 and 206. In addition, the machines had to run at 'half speed' ie 1800 revs/min so that very large blade annulus areas could be employed. Each Pickering LP turbine exhaust was the same size as the RL Hearn 200 MW units ie 150" (3.81 m) tip diameter, while for Bruce, new last stage LP blades 42" (1.07 m) long with a tip diameter of 170" (4.32 m) were designed.

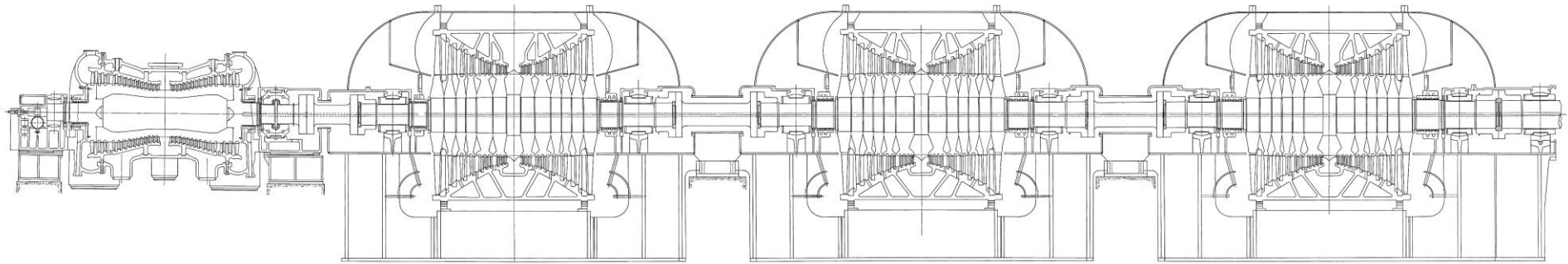

Fig.199 Pickering 540 MW 1,800 revs/min turbine 1966



Fig.200 Two of the eight Pickering units

Parameter	Fossil-fired unit	Pickering	Bruce
Power output	500 MW	540 MW	800 MW
HP stop valve mass flow rate	1.0	2.0	3.0
HP stop valve volumetric flow	1.0	5.0	7.4
LP turbine exhaust mass & volumetric flow	1.0	2.0	3.0

Table 6 Comparison between the relative inlet and outlet flow rates for Pickering and Bruce turbines compared with a 1960s 500 MW fossil-fired unit

The steam in the HP turbine was wet in every stage. At Pickering, the HP exhaust pressure was 74.4 lbs/in² abs (5.1 bara) which resulted in a wetness fraction of 11.8% at the HP exhaust at full load. If there had been no reheat, then the wetness fraction would have increased to more than 20% at the LP turbine exhausts. So the steam was reheated between the HP and LP turbines using live steam taken from the reactors. Parsons designed special heat exchangers with banks of finned vertical tubes for this purpose. Also, large cyclone separators were developed by Parsons which removed 95% of the water content in the HP exhaust steam before the steam entered the reheaters. This was considered to be an exceptional performance because similar results were not expected to be achievable with other separator types at this novel scale with the knowledge levels existing then. The possible alternative separator types were either wire mesh or corrugated plate designs and required the steam distribution at entry to be well ordered with a uniform low velocity. This could not be assured at the time Pickering was designed. The Parsons cyclone separator used a row of vanes to swirl the steam causing the water droplets to be ejected from the flow by centrifugal action where it was collected by a cage of louvred plates, figs. 201a and b [30]. A further set of vanes then de-swirled the steam to smooth the flow into the reheaters with only a small pressure drop.

The turbines and auxiliary plant therefore required considerable new knowledge in terms of how wetness levels inside the blade path affected machine performance, how much erosion might occur in the blade path and at casing joints due to high velocity wet steam, how best to design the unit to minimise long term degradation effects and how to design the water separators and reheaters reliably. Parsons invested considerable effort to investigate the behaviour of wet steam in depth using purpose built test rigs and experimental turbines in the laboratory and by collaboration with academia. The nature of this work is described in refs [30] and [31].

A special experimental turbine named Mary was created specifically to study flow behaviour inside the HP blade path with different types of blading. Reaction blading was favoured not only because it was fundamentally more efficient than impulse blading but the low stage loading, pressure changes, flow velocities, moderate changes in flow direction, etc were expected to produce low erosion rates. Observations showed that these factors beneficially affected the way water droplets formed and could be removed. From tests on Mary, it was found that the loss of stage efficiency as the wetness level increased through the HP blade path was lower for open-tipped, radial clearance blading than for shrouded blades with multi-fin seals, fig.202 [30, 33]. Since the CANDU units needed tall blades, the effect of tip leakage loss was less significant than for fossil-fired turbines, so the potential benefit of interleaved shroud seals was less important than the gain from fig.202 and the linked advantage that open-tipped blades would allow water to be centrifuged out from each stage. Every moving blade row in both the HP and LP turbines therefore used open-tipped blades. Fig.203 shows the HP blade path in which stages 1 to 9 were free-standing and the following stages employed lacing wires. A key feature was the use of an entirely smooth outer flow boundary where water could flow along the surface unopposed to be

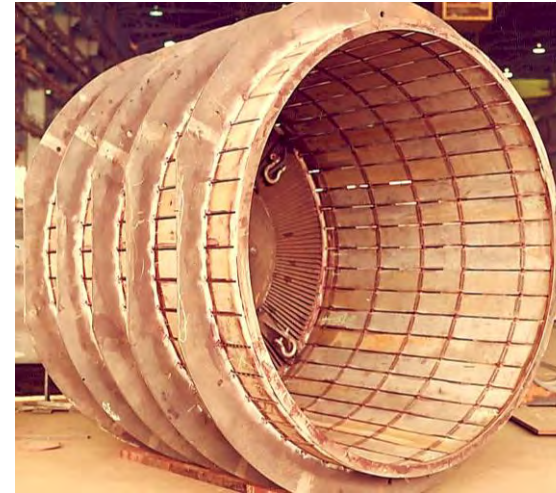
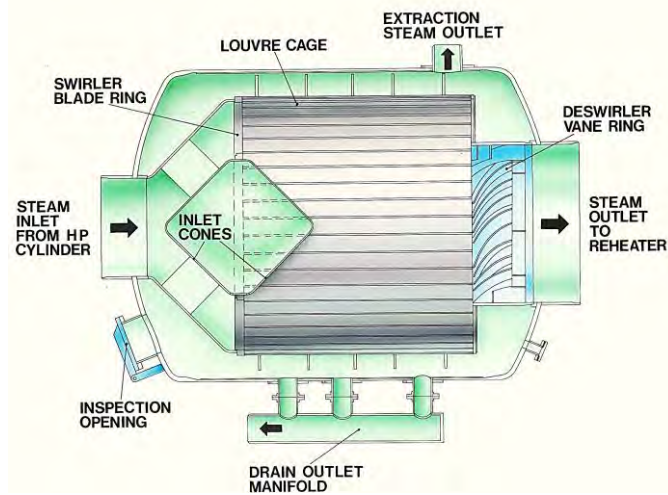

Fig.201a View of cyclone water separator, *left*, and fig.201b photo of a blade swirler ring and 2.9 m diameter louvre cage during manufacture, *right*

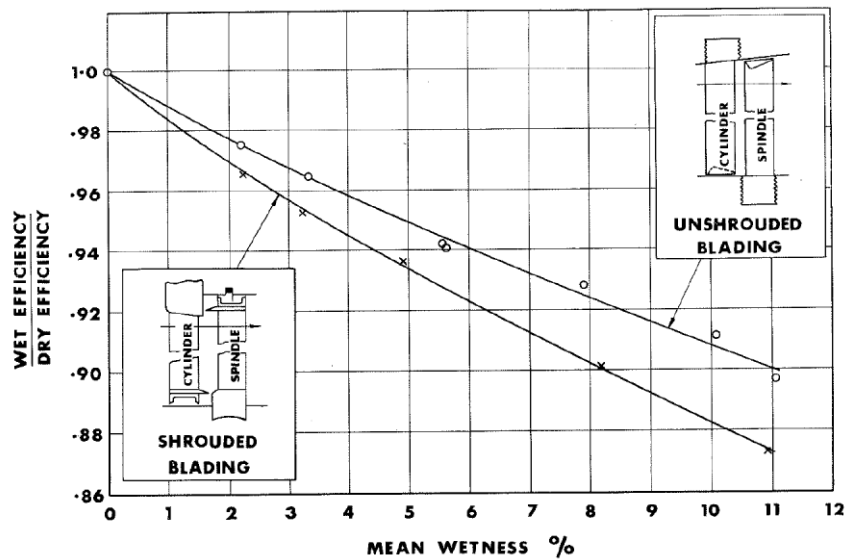

Fig.202 Reduction in blade efficiency with increasing wetness

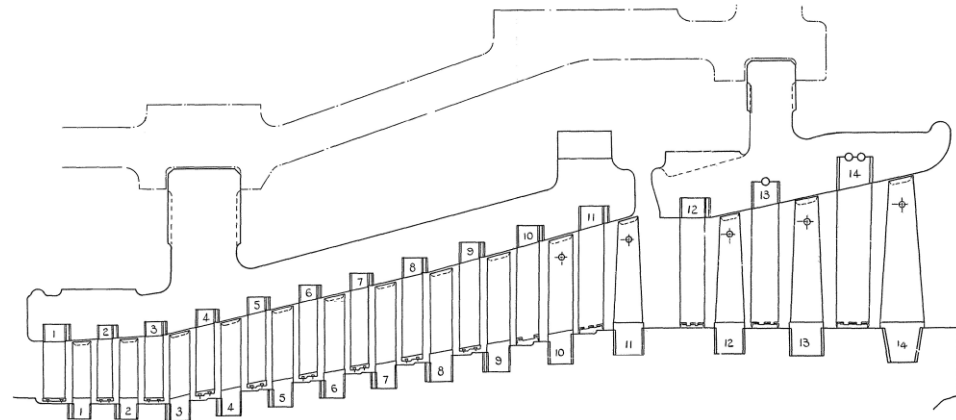

Fig.203 One flow of Pickering HP turbine bladepath

extracted via louvred plates at the extraction belts. This smooth boundary avoided the pockets required for blade shrouds where water could collect and act as a drag on the blades. Fig.204 shows the condition of the HP exhaust stages after 35 years service – the blades show no appreciable water erosion. The units exceeded their performance guarantees, so the development work was a success.



Fig.204 Pickering HP turbine blading stages 9 to 14 after 35 years' service

Some of the other key design decisions were as follows.

Materials with higher alloy content were selected to provide water erosion resistance. The minimum grade of material used for the blading was 12 CrMo with higher grades employed in the taller stages. All blade components (eg root fixing locking pieces) were also made from high alloy steels. The HP turbine rotor body was made from 2½ Cr Mo and the HP casings were cast in 2¼ Cr 1 Mo. The rotor was a hollow-and-stub design to reduce the weight on the bearings. This allowed the shaft ends to be made from 1½ CrNiMo so there was no risk of wire wooling at the bearing journal surfaces. Together with the use of appropriate steam chemistry and the control of local flow velocities, there was no appreciable loss of material by water erosion or erosion-corrosion from the rotor forgings or casings. This contrasted with the experience of other manufacturers where the loss of material by erosion-corrosion in some stations with boiling water and pressurised water reactors was severe and led to the use of 13 Cr rotors and casings to control it. A change of material was never needed on the Parsons units.

The Pickering LP turbine rotors were made from NiCrMoV discs mounted on carbon steel centre shafts, fig.199. At Bruce, the centre shafts were made from 1½ CrNiMo for higher strength. Once the risk of stress corrosion cracking (SCC) in disc type rotors which ran continuously wet was recognised after Hinkley Point (see earlier), the CANDU units were monitored carefully. Practically all rotors suffered no cracks at the disc bore, but after approximately 140,000 hours service, some cracks developed at Bruce. At the time this occurred, Parsons and Westinghouse

had joined Siemens and had shared information on stress corrosion. It was found that there was a threshold stress below which SCC did not occur, and since the 1980s, Siemens had developed methods of developing deep, beneficial, compressive residual stresses in the surfaces of shafts and discs to prevent SCC. In 2010, the opportunity was taken to install new disc type rotors at Bruce with this form of protection and more modern blading to provide a performance gain.



Fig.205 Bruce A turbine hall

Fig.206 shows a cross-section through the Bruce turbine line. The design is very similar to Pickering. The HP turbine was fully double-cased, fig.207a. This sketch shows the type 316 austenitic steel weld overlay which was applied in grooves on the horizontal joint and blade ring sealing faces to resist worming erosion. Fig.207b shows the special louvred water extraction belts which were developed on Mary. At two places, a small amount of steam was extracted from an extraction belt in one flow, passed through an external water separator and then re-injected into the corresponding belt in the opposite flow. To help reduce the size of the HP-LP cross-over pipes, main water separators and reheaters, an impulse stage was added at the front of the LP bladepath to increase the LP inlet pressure to 136.5 lbs/in² abs (9.4 bara). This reduced the HP turbine exhaust wetness level to 8.8%.

The CANDU units benefited from the low running speed. Applying the principles of dynamic similarity, the 800 MW 1,800 revs/min turbines at Bruce were nominally equivalent to units of 288 MW running at 3,000 revs/min. Consequently, stresses were much lower generally than those in the 500 and 660 MW 3,000 revs/min units and this helped to reduce the risk of crack initiation and other forms of degradation. The units operated successfully and at the time of writing were still in operation. Fig.205 shows the Bruce A turbine hall.

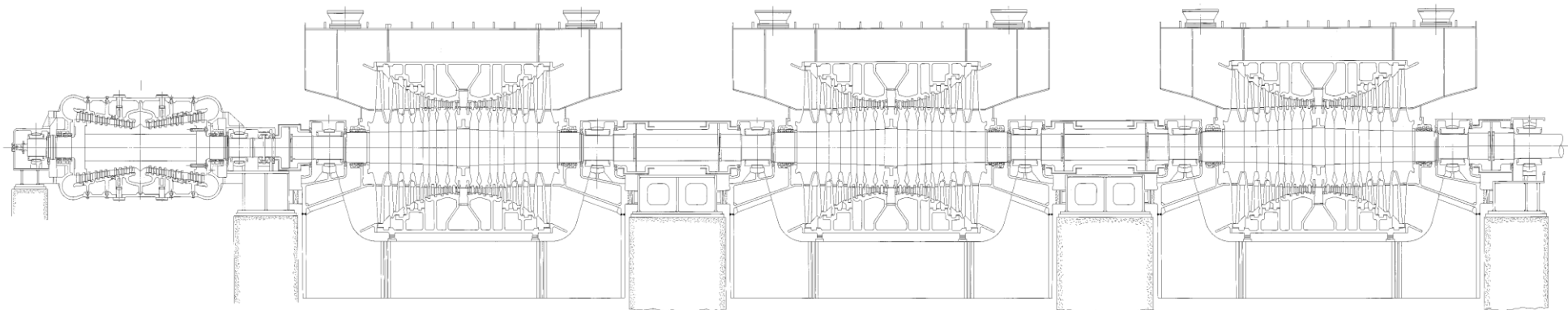

Fig.206 Bruce A 800 MW 1,800 revs/min turbine 1969

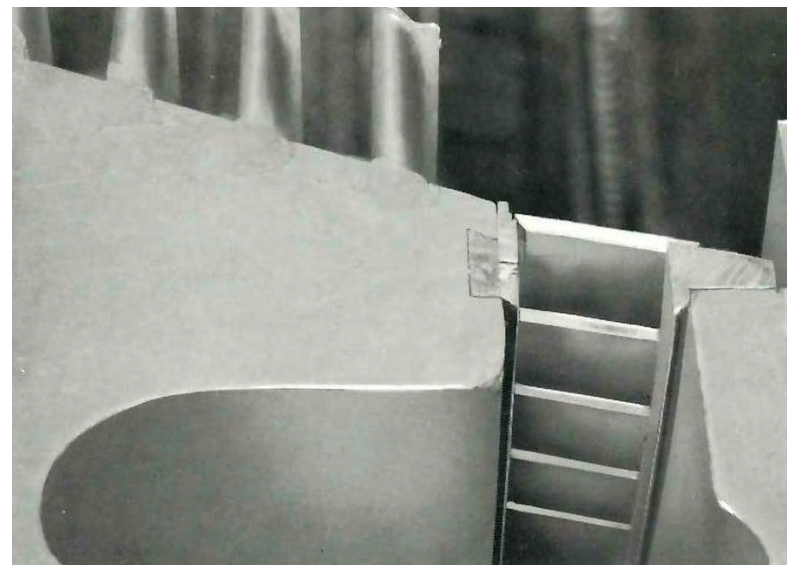
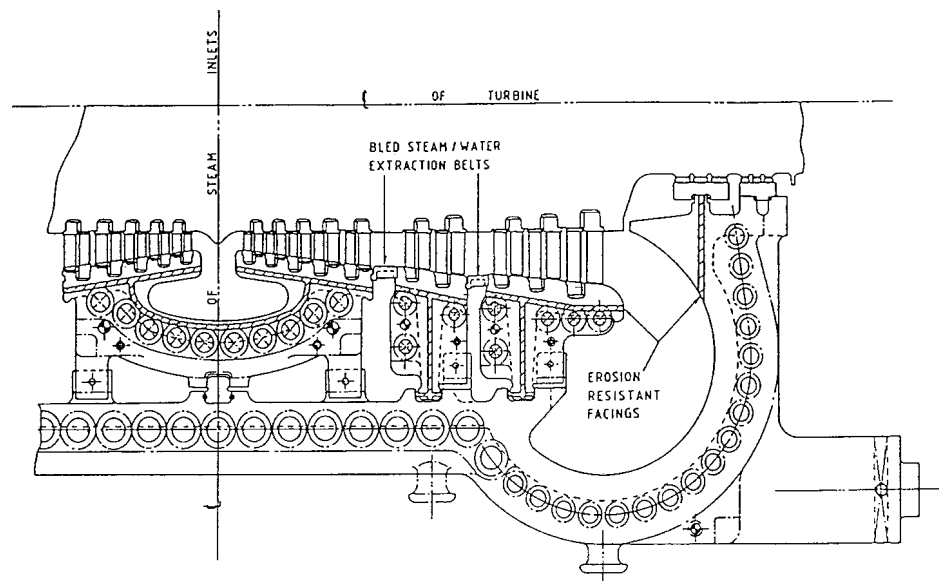

Fig.207a Local view of Bruce A HP turbine casing, *left*, and fig.207b close up view of louvred water extraction belt, *right*

Nanticoke 500 MW 3,600 revs/min units

In 1967, Ontario Hydro placed an order with Parsons for the first of eight 500 MW turbine-generators for Nanticoke power station located close to Port Dover on the shore of Lake Erie. For many years, Nanticoke was the largest coal-fired power plant in North America. It operated until 31st December 2013 when it closed as part of Canada's commitment to reducing emissions.

The units operated normally at 2,350 lbs/in² gauge 1000°F (162.0 barg 538°C) with reheat at 562 lbs/in² abs 1000°F (38.8 barg 538°C). They were also capable of running continuously at 5% over-pressure with the top feedheater isolated to give a maximum capability of 559 MW. There were 7 stages of feedheating.

Since the Ontario grid frequency was 60 Hz, the units operated at 3,600 revs/min. Applying dynamic scaling, 559 MW at 3,600 revs/min was equivalent to 805 MW at 3,000 revs/min, so the machines were highly rated.

Several alternative configurations were discussed with Ontario Hydro and the chosen arrangement was a machine with only four exhaust flows using 60 Hz scaled versions of the Drax last stage LP blades ie blades 30" (762 mm) long with a tip diameter of 113" (2.87 m). This was surprising because the station could achieve low condenser pressures due to the availability of cold cooling water. So, while the blades were strong enough to operate with just four flows, the exhaust area was limited. To help this, a condensing boiler feed pump turbine was employed to provide some additional exhaust area, fig.209. Even so, the average velocity leaving the last stage blades was Mach 0.92, higher than the usual design limit of Mach 0.85. The velocity was normally limited to avoid potential fatigue failure of blades due to non-uniform pressure distributions and shock waves caused by supersonic flow around plates and bars in the exhaust structure. Parsons developed a new exhaust type with the internal support struts and plates placed further from the blades to address this. The blading was designed before computational fluid dynamics tools existed, and so should have suffered from non-uniform flow distribution and other issues typical of all large turbines in the 1960s, but the high flow rates relative to the exhaust area had the beneficial side effect of forcing the steam to distribute more evenly, which led to good LP turbine performance.

A cross-section through the turbine line is shown in fig.208. The HP and IP turbines were fully double-cased with monobloc forged rotors. Rateau stages were provided to reduce the steam temperature in the same way as other large Parsons turbines. The HP turbine employed integrally cast nozzle chests with horizontally split casings and was throttle governed.

The LP turbine rotors were also monobloc forged designs using reaction blading mounted in circumferentially serrated grooves and L-2, L-1 and L-0 moving blades were installed in side entry fir tree root fixings. Unlike the 500 MW sets of 1961 which used a shared exhaust structure for all of the LP turbines, the Nanticoke LP turbine casings were separate and were supported on a dedicated concrete foundation.

Nanticoke turbine hall was very long, fig.210. Pedal cycles were available to travel from one end to the other.

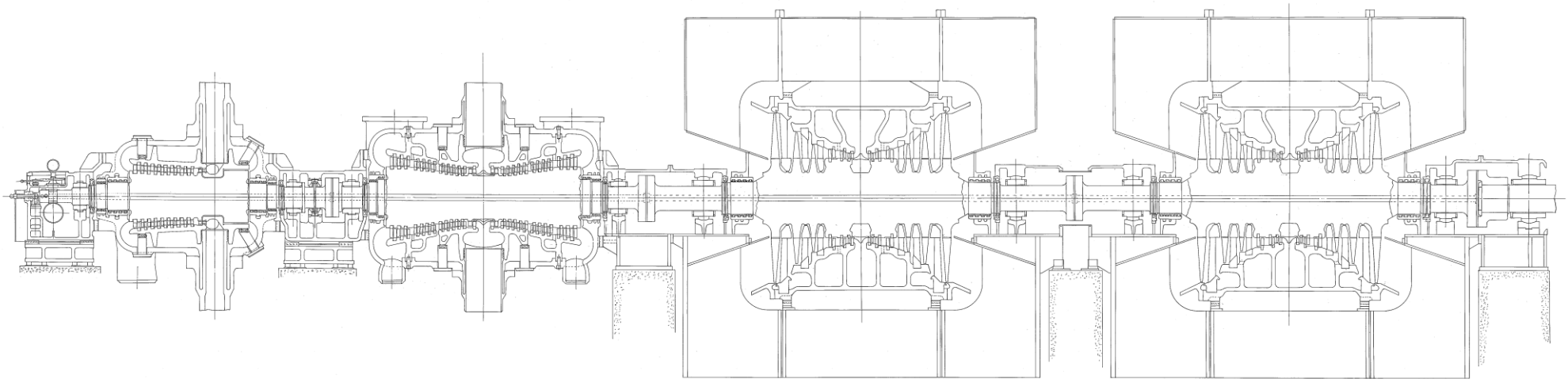

Fig.208 Nanticoke 500 MW 3,600 revs/min turbine 1968

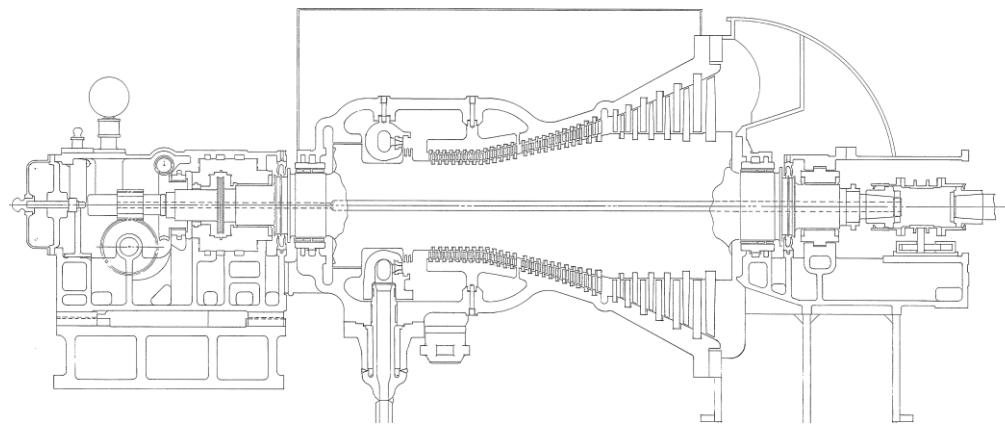

Fig.209 Nanticoke boiler feed pump turbine (BFPT) which provided additional exhaust area.

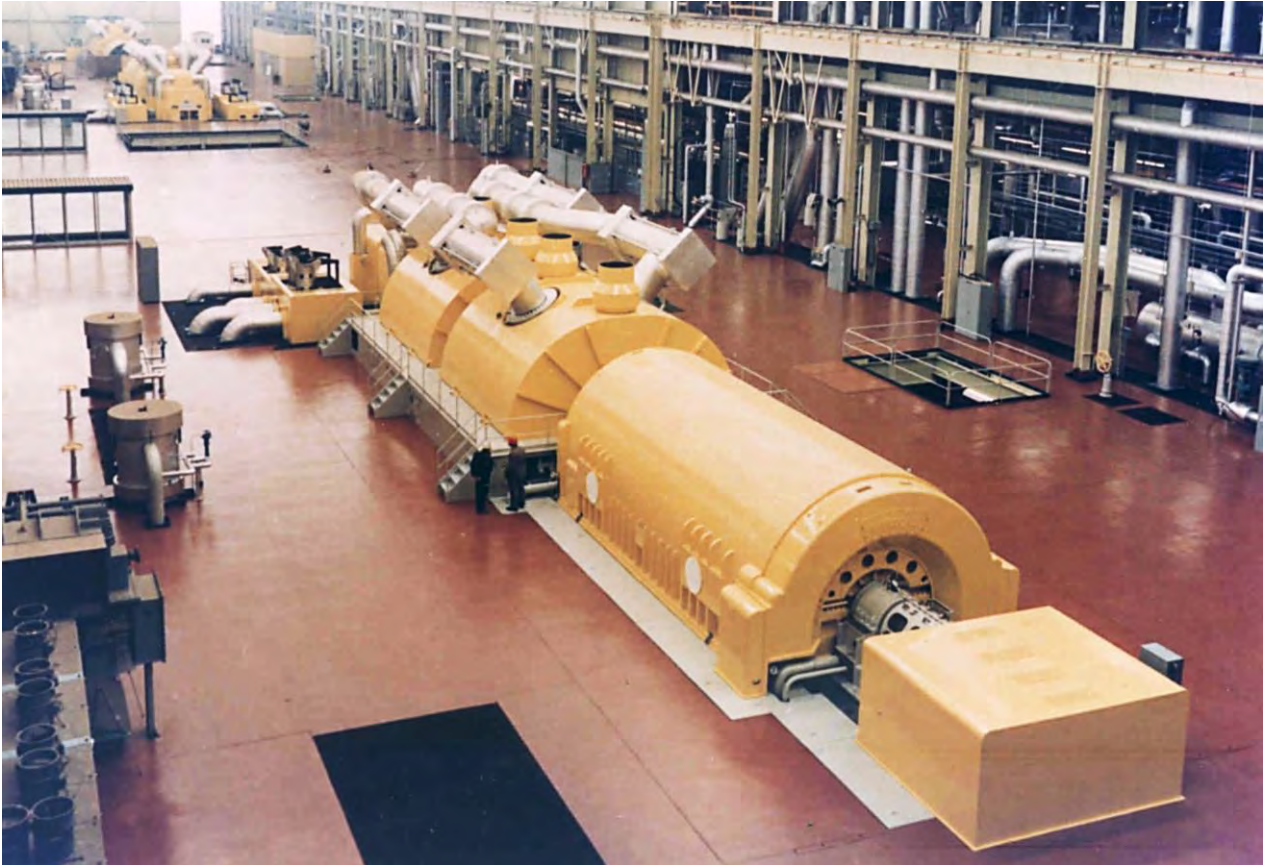

Fig.210 Three of eight 500 MW TG sets in Nanticoke turbine hall.

Development of blades for new machine types

With the considerable growth in machine size and changes in technology, Parsons consulted with their major customers and developed new blades to suit the expected next steps in turbine-generator design.

For example, in 1967, a new LP turbine blade 44" (1.12 m) long with a tip diameter of 160" (4.06 m) at 3,000 revs/min was developed for possible 1000 MW units which the CEGB was considering. This blade used the Erith inverted arch coverband and was mounted on a side entry fir tree root fixing like a larger version of the Drax blade.

In the early 1970s, Parsons developed a 40" (1.02 m) long blade with a tip diameter of 148" (3.76 m) at 3,000 revs/min to allow 1300 MW fossil-fired, AGR or SGHWR (steam generating heavy water reactor) units to be manufactured. This was the first blade designed by Parsons using the newly emerging computational fluid dynamics software which allowed analysis of the flow behaviour inside the blade passages and from blade row to blade row in the machine. This was the first Parsons blade to be mounted on a curved side entry root fixing.

These blades were developed up to the point of model turbine testing and verification of vibration characteristics, but none of these plant types were ever built.

Rockwell Parsons joint venture in the USA

In 1968, CA Parsons & Co was at its' peak. The company was the second largest turbine-generator manufacturer in the World with a work force of around 12,500. Since the 1930s, Reyrolle had been a major share-holder and partner of Parsons. To strengthen their market position, the two companies merged and formed Reyrolle-Parsons. They then proceeded to acquire further companies eg the Bruce Peebles transformer business in Scotland to build their business interests.

In 1969, Reyrolle-Parsons decided to establish a joint venture company in the USA to try to win a larger share of this market, where power utilities almost invariably ordered plant from the domestic manufacturers. They approached the North American Rockwell Corporation who were a major manufacturer in aerospace and other engineering sectors. On the 1st July 1970, negotiations were completed and the formation of the Rockwell Parsons company was announced "to market, manufacture and service turbines and generators" [34]. The company was 50:50 owned with headquarters in Pittsburgh, Pennsylvania. TG manufacture was to be undertaken at Heaton Works in Newcastle initially with servicing carried out in the USA. Manufacture in the USA was expected to follow if sufficient orders were won. The capacity of the US power grid was around 30 GW in 1970 and this was expected to double within 12 years.

With an existing high demand for turbine-generators already on order and the prospect of further contracts from the American market, Parsons decided to concentrate their resources on TGs. Parsons transformer business was transferred to the newly acquired Peebles company. Parsons gas turbines were state-of-the-art in 1970, but with low operating temperatures by modern standards, they were not efficient enough yet to win significant orders. The Gas Turbine Design Dept was closed and the people transferred to steam turbine work. The Compressor Dept had sold significant numbers of machines but this work was considered to be of lower importance than steam TGs, so this department was closed also. This had a major effect on Parsons in the 1980s when there was a rapid growth in demand for large gas turbines and combined cycle power stations. Parsons did not then have a gas turbine product line to offer.

Table 7 summarises the turbine-generators which were offered to the US market. The fossil-fired product line extended up to 1300 MW with steam conditions up to 3500 lbs/in² gauge 1000°F with reheat to 1000°F (241.3 barg 538°C/538°C). The design rationale was as follows:

(a) Units up to 400 MW at 3,600 revs/min

Using the principles of dynamic scaling, this unit size was equivalent to a rating of 576 MW at 3,000 revs/min. From table 7, a machine with just one double flow LP turbine was offered with a new last stage LP blade 33.5" (851 mm) long equivalent to a 40" (1.02 m) long blade at 3,000 revs/min.

(b) Units up to 500 MW at 3,600 revs/min

In this size range, the Nanticoke configuration fig.208 was offered since this already existed ie monobloc rotors were used with all reaction bladepaths apart from a Rateau inlet stage in the HP turbine.

(c) Units up to 800 MW at 3,600 revs/min

For this rating, impulse IP and LP turbines were proposed similar to Drax. An impulse IP turbine was selected for the following reasons. A rating of 800 MW at 3,600 revs/min was equivalent to 1,152 MW at 3,000 revs/min ie very highly rated. A single, double flow IP turbine was desired for performance reasons. The best cost and efficiency was achieved when the last stage IP blade was as tall as possible, as explained earlier. At this rating, Parsons' reaction blade root fixing wasn't strong enough to carry a tall blade and so it was necessary to change to pinned fork root fixings. This determined the IP turbine construction. There was no comparable reason to use impulse LP turbines. This was done most probably because the nearest reference machines (Drax and Hunterston B) employed impulse LP designs.

(d) Units up to 1,300 MW at 3,600 revs/min

The largest fossil-fired machine offered – 1,300 MW at 3,600 revs/min – was dynamically equivalent to an 1,872 MW TG set at 3,000 revs/min. At this rating, a cross-compound arrangement had to be used.

(e) Nuclear units up to 1,200 MW at 1,800 revs/min

The majority of nuclear units in the USA used saturated steam from either a boiler water or pressurised water reactor. The flow rates through the turbine were large and so the turbines were required to run at 1,800 revs/min. The construction was the same as Bruce ie all reaction designs with open-tipped blades, hollow-and-stub HP turbine rotors and disc construction LP turbine shafts. A new last stage LP blade 52" (1.32 m) long was offered. The HP stop valve pressure was expected to be between 570 and 965 lbs/in² gauge (39.3 and 66.6 barg). Cyclone water separators and live or bled steam reheaters were proposed.







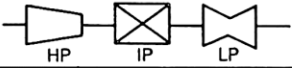

(f) HP turbines for sub-critical conditions up to 2,500 lbs/in² gauge (172.4 barg)

These were based on the Nanticoke and Hunterston B designs, figs.188 and 208 ie horizontally split, twin shell casings with integrally cast nozzle chests, throttle governed with a Rateau inlet stage followed by reaction blading.

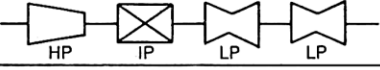
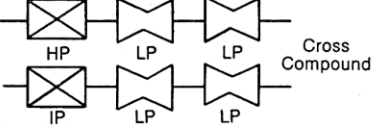
(g) HP turbines for super-critical conditions up to 3,500 lbs/in² gauge (241.3 barg)

Parsons offered a new HP turbine design in which a triple shell casing was used with integrally cast nozzle chests, fig.211. It employed a Rateau stage at inlet to reduce the pressure and temperature quickly and so allowed the use of conventional low alloy steels. There was a 'flow turn-around' midway through the reaction bladepath to regulate the pressure differentials and temperatures acting on each section of the casing. This turn-around would have caused a pressure loss of at least 1%. It's unclear why this design was offered when the Drax-type barrel HP turbine had only just been developed which achieved higher efficiency and lower cost. It seems likely that the horizontally split casing design shown in fig.211 was considered to be more attractive to American customers and would be easier to service.

All of this work was ultimately wasted since Rockwell Parsons didn't win a single order and the damage caused at Heaton Works by the closure of the Gas Turbine and Compressor Depts couldn't be undone.

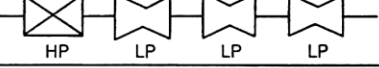
Type/ Speed	Rating Mw	Turbine Arrangement	Last Stage		Steam Flow Lb/Hr/Exhaust	Overall Length Feet*
			Blade Length in.	Annulus Area Ft ² /Flow		
Conventional 3600 RPM	400		33½	66.1	870,000	147
	500		30	54.3	535,000	154
	800		33½	66.1	750,000	175
	1300		33½	66.10	633,000	{ 154 156
Nuclear 1800 RPM	540		37	91.2	695,000	185
	540		42	117.25	1,043,000	150
	800		42	117.25	940,000	218
	800		42	117.25	1,419,000	180
	1200		42	117.25	1,231,000	230
	1200		52	168.0	1,227,000	233

*With Rotating Rectifier Excitation

Table 7 Rockwell Parsons product line

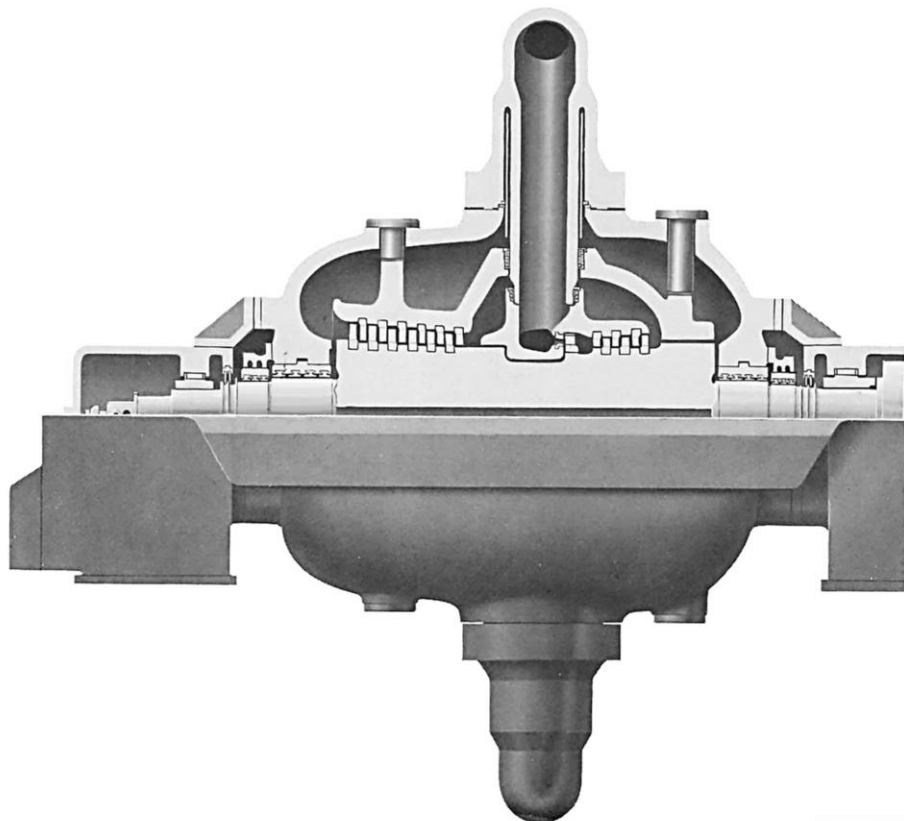

Fig.211 Supercritical HP turbine design developed for the US market

A period of relatively little change in market demand

In the 1970s, electricity in many countries was produced by large power utilities which often held a monopoly position in their respective countries, provinces or states. It became clear that these companies generally were not going to commit to building power plants with elevated operating conditions or new technologies. In Parsons' markets, no one was building super-critical plant, for example, after adverse experience with prototype stations in the 1950s and 60s. Similarly, combined-cycle plant was not being considered despite offering a large efficiency increase. In a few countries, machines larger than 1,000 MW were being built but these were in areas eg USA, Germany and Russia where Parsons was unsuccessful or was unable to access the market. Parsons traditional customers continued to specify turbine-generators in sizes up to 700 MW rating operating at sub-critical steam conditions, and so, the company continued to offer the designs which had been developed in the late 1960s.

This continued until the 1980s, when privatisation of the electricity market brought increased competition between generating companies and a surge of investment in new types of plant. While waiting for the opportunity to offer machines for more advanced steam cycles, Parsons continued to develop turbines for established power plant types with the aim of increasing efficiency, increasing the life and integrity of the units and lowering costs.

European and Australasian 200 and 250 MW 3,000 revs/min units

The next new family of turbines was designed in 1970 and sized for 200 and 250 MW applications at 3,000 revs/min. These were supplied to utilities in Europe, Australia and New Zealand. The HP stop valve conditions were 2000 to 2364 lbs/in² gauge 1000°F with reheat at 1000°F (138 to 163 barg 538°C/538°C). Either 6 or 7 stages of feedheating were used according to customer preference. A cross-section through one of these machines is shown in fig.212. The key difference was that an all reaction IP turbine was used rather than a GEC Erith impulse design.

Looking at each cylinder in turn, the key features were as follows:

The HP turbine was double cased with separate nozzle chests and was nozzle governed. Since most Parsons turbines were required to undertake full heat rate testing including measurement of the performance at part loads, four separate nozzle chests were used. This allowed the size of each nozzle arc to be matched exactly to the performance guarantee / test points. Also, separate nozzle chests were considered to be best for stress reasons. A Rateau stage was used to withstand the forces associated with nozzle governing and to reduce the pressure and temperature quickly. Otherwise, 600 series reaction blades were used. The shafts were monobloc designs.

The IP turbine used only reaction blades without a Rateau stage at inlet since the IP stop valve temperature was only 1000°F (538°C). The shaft was a monobloc design and was cooled using HP turbine exhaust steam. The cylinder was double-cased.

GEC Erith type impulse LP turbines were used. The LP outer casing was larger than previous machines to achieve lower exhaust losses. This led to chilling of the exposed inner casing by the wet exhaust steam which caused the horizontal joint to open locally around the inlet belt with a resulting steam loss. Once this was diagnosed, thermal shields were placed over the inner casing in all subsequent Parsons LP turbines to avoid this.

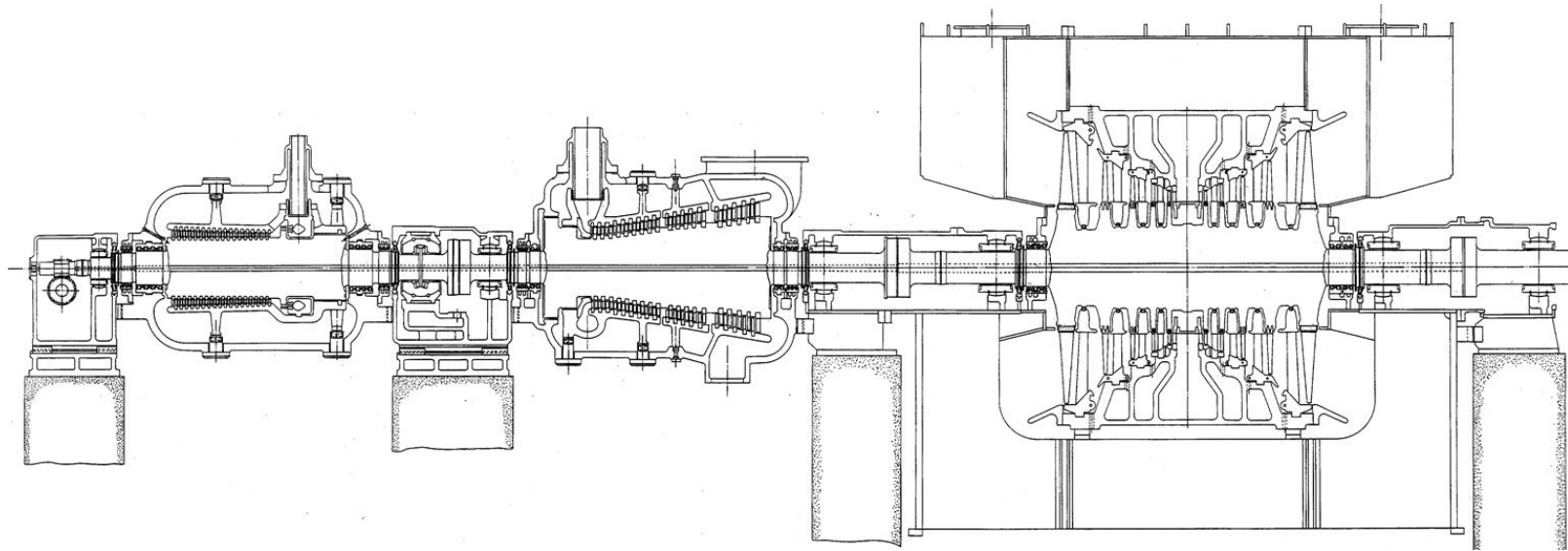

Fig.212 Parsons 200 and 250 MW 3,000 revs/min turbines 1970

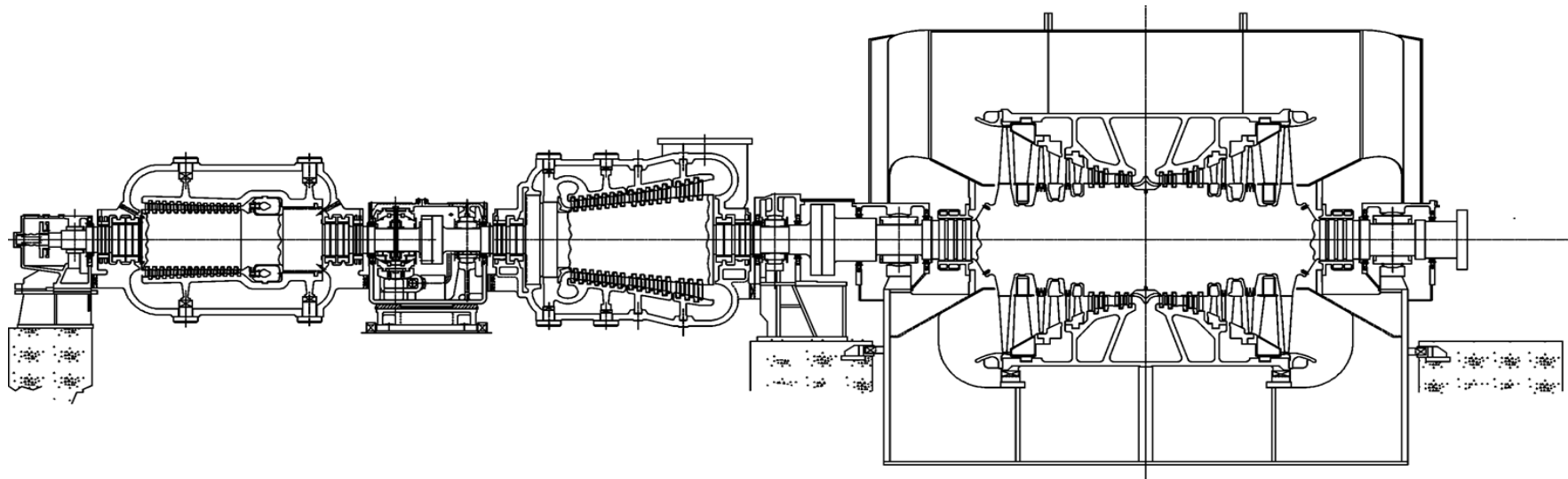

Fig.213 Pulau Seraya stage I 250 MW 3,000 revs/min turbine 1983

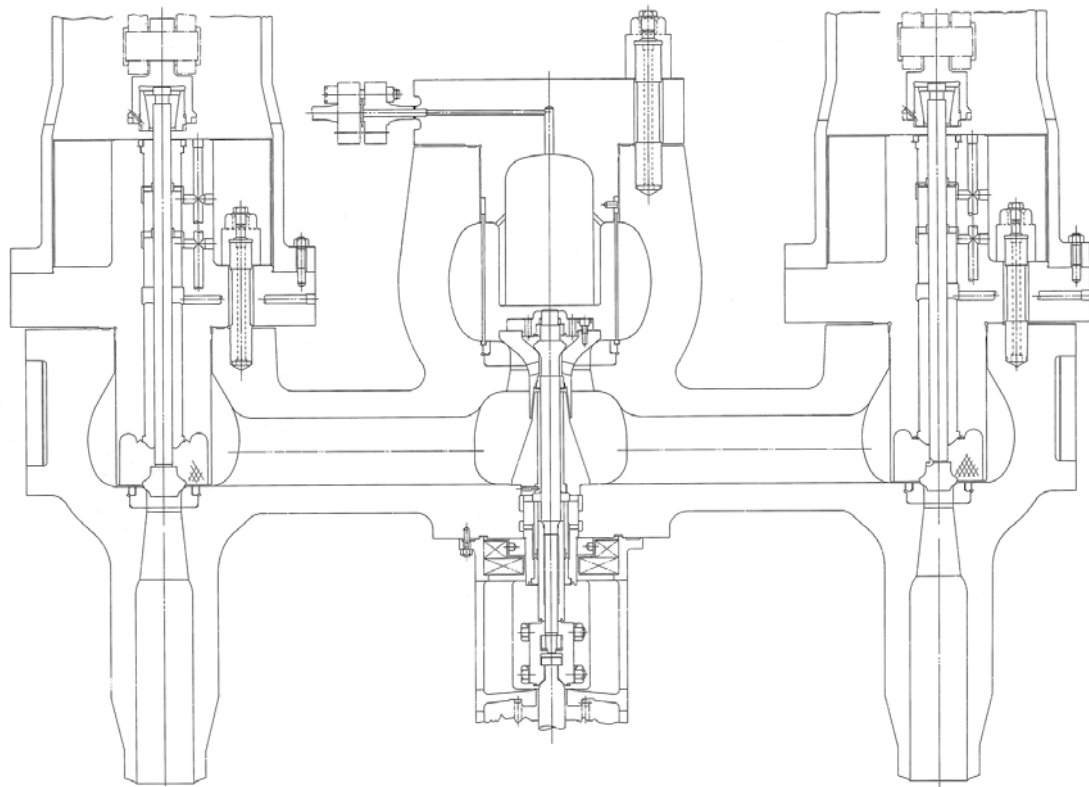

Fig.214 Pulau Seraya stage I HP steam chest

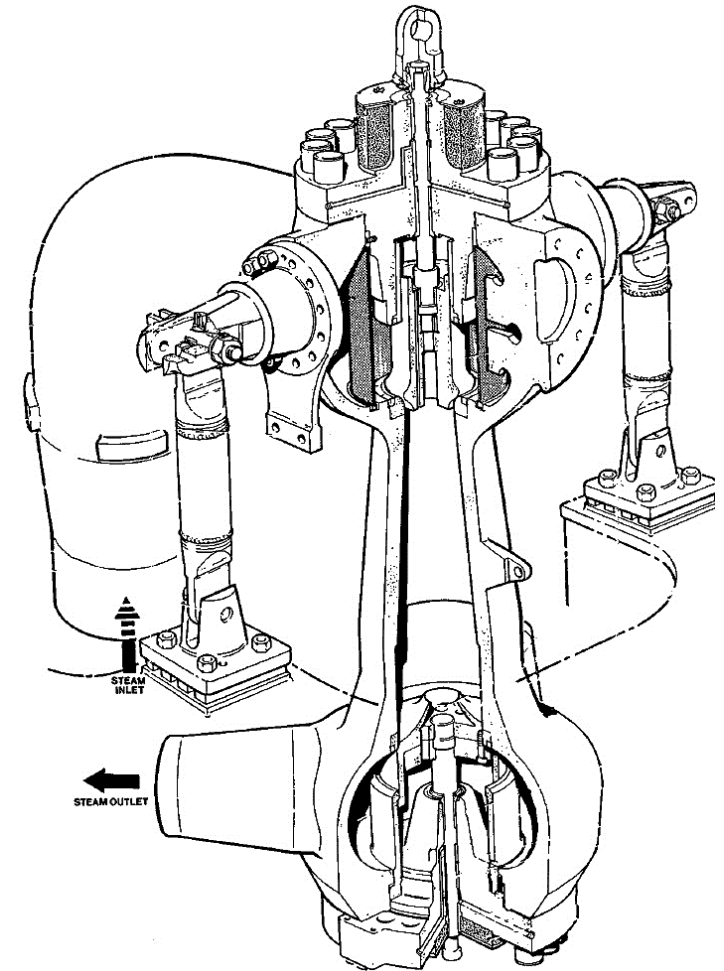

Fig.215 Pulau Seraya stage I reheat steam chest

The NEI years and the impact of computational fluid dynamics 1977 to 1989

Mergers and take-overs of power generation manufacturers continued during the 1970s. Reyrolle Parsons merged with Clarke Chapman in 1977 and formed a new organisation Northern Engineering Industries (NEI). Parsons began trading as NEI Parsons Ltd. Further acquisitions followed quickly. During the 1980s, the constituent companies included:

Power generation: Parsons (large turbine-generators, condensers, feedheaters, pipework), Reyrolle (switchgear), Clarke Chapman (cranes, steelwork plus ship, railway and petrochemical products), International Combustion (boilers), Allen (small turbines, diesel engines, compressors, gearing, valves), Peebles (transformers, small generators, large electric motors), Thompson (nuclear plant, water treatment, fabrication plus bridge and road transport products), Nuclear Systems, Electronics / Control Systems, International Research & Development (nuclear technology, materials development, contract R&D).

Project management: NEI Power Projects (to support customer requirements), NEI International (to develop the NEI businesses).

Overseas companies in Africa, Australia, Canada, India and the Pacific Rim countries.
Other activities: Mining equipment.

Pulau Seraya stage I 250 MW units

By 1980, Parsons decided that reaction blading should be employed in all cylinders to achieve the best performance. Alongside this, computational fluid dynamics was a major discipline which allowed detailed analysis of flow behaviour inside the blade path and was used along with lab testing and traverse measurements on full size turbines. In the early 1980s, the analysis of flow from stage to stage ('throughflow' calculations) and calculation of the conditions around the surface of blade aerofoils and spanwise across each blade passage ('blade to blade' calculations) had to be carried out separately, but some powerful software tools were available. These were applied to all units starting with turbines of 250 to 400 MW rating. The first machines to be built were three 250 MW sets for Pulau Seraya stage I power station in Singapore, figs.213-216.



Fig.216 Pulau Seraya stage I turbine hall

The resulting changes principally affected the design of the LP turbine and may be seen by comparing fig.213 with the previous design fig.212. A substantial increase in performance was achieved due to the following factors:

- A smooth conical outer flow boundary was developed without the ‘steps and stairs’ geometry of previous diaphragms which could cause flow separation.
- The flare angle of the outer flow boundary was reduced from 50° to less than 30°.
- Wide chord, tapered diaphragm blades which were leaned at an angle relative to the radial line were adopted.
- Blade settings and dimensions were chosen which produced a more uniform mass flow distribution with an increased degree of reaction at the blade root, improved steam incidence angles and lower peak velocities.
- Four reaction stages were used at the inlet end of the blade path.
- More extensive seals were employed with inclined sealing fins.
- An improved, larger exhaust hood was used.

The lower flare angle, the reaction stages and larger exhaust hood increased the distance between bearing centres of the LP turbine shaft from 4 m to 6 m approximately. This was a large increase but was worth it as the LP turbine efficiency increased to over 94% (evaluated on a ‘dry excluding leaving loss’ basis). The moving blade aerofoils were still pre-CFD designs, so this was considered to be a satisfactory result. The last stage LP moving blade, for example, was a 30” (762 mm) profile from the 1970s with an inverted arch coverband.



Fig.217 Dr John Grant

In parallel with the design of this turbine family, John Grant - Parsons leading aerodynamicist and blade design specialist, was developing a new generation of blades using CFD. John joined Parsons from the Royal Aircraft Establishment, Farnborough in 1979 and brought considerable knowledge. He designed new LP turbine blades, reaction blades, control stage blades plus blades for specialised purposes in the 1980s and 90s. Subsequently, he was placed in charge of turbine-generator development, and in 1996, became Engineering Director. John retired in 2003.

The first blades to be produced were improved last stage LP moving blades and diaphragms since these gave the greatest gain. Replacement blades were designed which could be installed on the same root fixings as the existing 33.8” and 36” long last stage blades. This meant that both existing and new units could employ the blades. By changing only certain blade rows in the

LP turbines as part of an upgrade package, this allowed the performance gain of these stages to be measured and it confirmed the validity of the design methods. Improvements in heat rate exceeding 3% together with an increase in power output of 66 MW on a 660 MW unit were achieved, for example. Improved versions of Parsons 24" (610 mm) and 30" (762 mm) long blades followed.

As mentioned earlier, these new LP turbine blades, which became known as 'high twist' blades, were accompanied by improvements in mechanical design. Refined finite element analysis and the careful avoidance of stress raisers reduced peak stresses in the blades. The inverted arch coverband was superseded by the articulating tip strut described earlier, figs 195 and 196.

Longer blades 1070 mm (42.13") long with a tip diameter of 3.91 m (154"), fig.218a and b, and 1200 mm (47.24") long with a tip diameter of 4.31 m (170") at 3,000 revs/min were developed in the 1980s. The L-0 and L-1 stage moving blades were mounted on curved side entry root fixings with a locking wedge fitted underneath the root block to eliminate the stress raisers associated with aerofoil overhangs and the C shaped locking groove used in 1950s and 60s blades.

The family of high twist blades was very successful in terms of performance and integrity and was used until 1997 both in Parsons and other manufacturers turbines.



Fig.218a 1070 mm long high twist last stage LP blade with a curved side entry root fixing, *left*, and fig.218b an assembled blade row on a vibration test wheel, *right*

In the mid-80s, a new reaction blade profile was developed called the R-series design. This was a replacement for the 600 series profile, see figs 219a and b. Again using CFD, the new profile provided higher performance and a stronger blade. Fig.220 shows a comparison of the performance curves for R series and 600 series blades plotted against the steam incidence angle. When the steam entered the blades at exactly the design angle (ie incidence = 0°), the R series profile gave an improvement in loss coefficient equivalent to at least 1.5% on stage efficiency at the design velocity ratio. More than this, whereas 600 series blades maintained their performance over a range of incidence of approximately $\pm 20^\circ$, R series maintained its efficiency over a range of $\pm 45^\circ$. This was a remarkable result and was related primarily to careful design of the nose region which was defined as a small nose radius followed by a progressively increasing radius of curvature. The ability to withstand a wide range of incidence wasn't an essential requirement for a power generation turbine which ran at constant speed with no significant change of flow direction over the normal working load range, however it provided three advantages. Firstly, it allowed tall blades to be manufactured without twist because the variation in flow direction from hub to tip could be accommodated. Secondly, design engineers could vary the stage loading to reduce the number of blade rows while maintaining high performance. Thirdly, if the turbine had a steam extraction at a controlled pressure or some other factor which caused the flow direction in the blade path to change, then the performance remained at optimum.

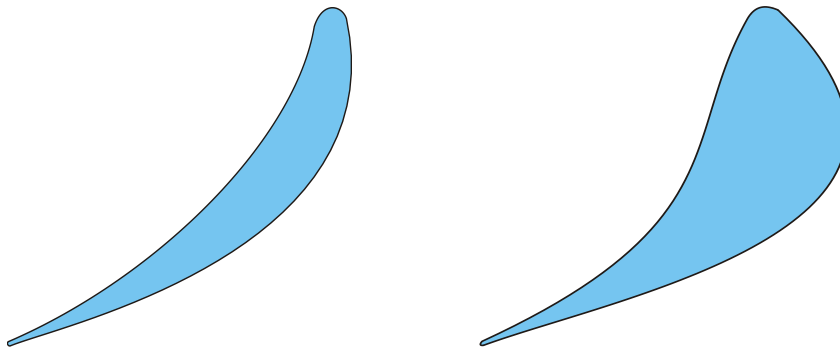

Fig.219a 600 series aerofoil profile, *left*, and fig.219b the new R series design, *right*

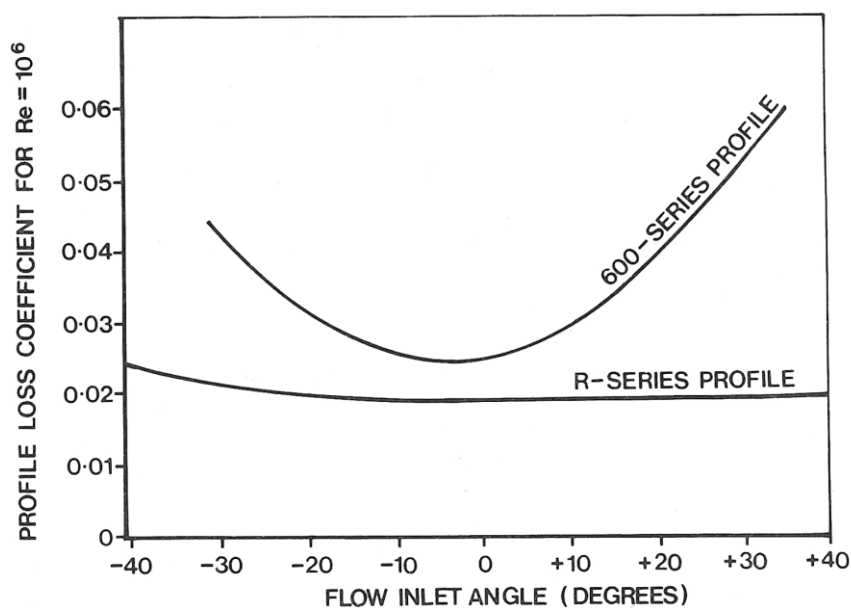

Fig.220 Performance curves for R series and 600 series blades

In addition to this, the blade was optimised for a pitch/chord ratio of 0.75 rather than 0.60 (600 series) or 0.50 (400 series). This benefited the aerodynamics and reduced the number of blades per row to save cost. The optimum ratio of blade throat opening to pitch was reduced from 0.37 (600 series) to 0.325 (R series). Smaller values of opening/pitch improved the stage efficiency by increasing the rate of change of momentum in the flow in the direction of shaft rotation and resulted in taller blades which reduced secondary losses.

The strength of the profile was increased substantially (the minimum bending modulus was 4 times stronger than standard 600 series and 2.3 times stronger than maximum reinforcement 600 series blades) and so narrower blades could be used which improved secondary losses further. The thicker profile also allowed different forms of manufacture. Initially, it was thought that the blade could be made in advance of orders in standard lengths, then cropped to suit a specific machine, a single round tenon could then be formed and a coverband attached by robotic riveting. In practice, the riveting process could not be developed satisfactorily, so this aspect was discontinued. Instead, the blade was made with integrally machined shrouds ie ILS construction, with groups of blades vacuum brazed into segments in the usual Parsons way. Another process change involved making a circular preform from forged bar material, then pressing this to form the aerofoil precisely in one step, encapsulating the aerofoil in a low melting point alloy to protect it while the root block and shroud were finished on a milling machine, removing the encapsulation and brazing the blades into segments. This was intended to reduce the amount of metal needed to make a blade and reduce tooling costs. This approach was used, but by the 1990s, the cost of blade materials changed and it became economic to simply machine the blades directly from rectangular or rhomboidal forged bar.

The first application of the R series blade was an upgrade for the Thorpe Marsh 550 MW HP turbine described earlier, see fig.149. The first new turbine to use R series blades was a 350 MW unit for Lamma Island PS in Hong Kong, please see next section.

Two further variants were also developed. The HL series was a version of the R series designed for high stage loading applications (ie 50% more energy released per stage) to reduce the stage count with a minimum opening/pitch ratio of 0.265 to help maintain a satisfactory blade height on turbines of 30 to 100 MW at 3,000 revs/min. In addition, RT blades included a degree of twist to suit the exhaust end blades of large IP turbines. The untwisted R series aerofoil could have tolerated the change in steam incidence angle in these stages, but since there was no extra cost for including twist on milled blades, the optimum blade shape was used.

Once the new reaction blades were established, new control stage blades were developed. In this case, a new trailing edge shape was adopted for the nozzles. The stage achieved higher performance than past designs, but at one station the nozzles suffered a vibration failure and had to be modified.

Steam chest design also moved on. By 1980, all new HP and reheat steam chest bodies were made from high quality castings. On Pulau Seraya stage I, the HP steam chest fig.214 followed the principle of the Drax type HP steam chest ie physically separate valve chambers were employed with near-ideal pressure vessel shapes except that there was only one emergency stop valve (ESV) per chest. Similarly, the reheat steam chest fig.215 was essentially one half of a Drax reheat chest. The use of castings allowed the wall thickness to be shaped more effectively than was possible with forgings. A special surface finish was used around the internal corner radii to maintain thermal fatigue resistance. The HP ESV was an inverted valve developed from the GEC Erith style arrangement to allow the upstream pipes to be pressurised early during each

start-up. The steam chest covers were now sealed using bolted face-to-face joints with spiral wound gaskets since the earlier Bridgman joints had proven to be troublesome.

Lamma Island Unit 6 350 MW at 3,000 revs/min

This was the first turbine which used CFD-designed blades in every stage, fig.221. Steam conditions were 2,400 lbs/in² gauge 1050°F (165.5 barg 566°C) HP and 550 lbs/in² abs 1000°F (37.9 bara 538°C) reheat. There were 8 stages of feedheating with the highest tapping coming from midway along the HP turbine bladepath at 867 lbs/in² abs 768°F (59.8 bara 409°C). This was the first time this was done. Since the aperture in the HP turbine inner casing for the extraction pipe produced an upthrust on the casing, a dummy pipe – in effect a balance piston – was provided in the top half casing to counteract it.

The reaction stages were designed using computer software which automatically optimised the blade dimensions for peak performance, created drawings by electronic data transfer and sent data for machine tool operation to the factory directly (CAD/CAM). Since R series blades were much stronger than 600 series, narrower aerofoil chord widths could be used. The resulting HP and IP turbine bladepaths were substantially shorter than previous machines – in particular, the IP turbine bladepath was 29” (737 mm) shorter than an equivalent 600 series design. This created a challenge when producing the turbine layouts as there was little space to include the feedheat extraction belts in the turbine casing and yet more extractions had to be provided than before. This resulted in the complex IP cylinder arrangement shown in fig.221.

In previous machines, the pressure ratio across the HP turbine Rateau stage at full load was typically between 1.20 - 1.30 to 1. To maximise the performance, for Lamma Island, the pressure ratio was reduced to 1.14:1. This transferred heat drop from the Rateau stage onto the reaction blades which were more efficient while retaining the advantages of nozzle governing. This pressure ratio meant that the stage changed from sub-sonic to supersonic flow as the number of nozzle arcs in service changed. This was the lowest pressure ratio which Parsons was prepared to adopt for an impulse stage. At lower values, the stage would have operated under conditions where the flow coefficient of the nozzles varied with pressure ratio such that the swallowing capacity of the turbine could have become sensitive to small variances.

The LP turbine employed 3 reaction stages and 3 variable reaction LP stages. The L-1 and L-2 moving blades used pinned fork root fixings for resistance to corrosion fatigue and stress corrosion. The last stage blade was mounted on a standard side entry root fixing.

The construction of the turbine was conventional for Parsons – fully double cased cylinders with monobloc turbine rotors, but there were some refinements. For the first time, high alloy nozzle chests were used in the HP turbine. Within the industry, there was a lot of discussion in the 1980s about 9 Cr 1 Mo (modified) which was a promising steel developed in America. It was claimed that this did not suffer a drop in creep properties after 10,000 – 20,000 hours in service which every other high temperature steel experienced. Since it wasn't certain that these claims were reliable, Parsons decided to use 12 CrMoV for the nozzle chests at Lamma Island while studies on the 9 Cr steel continued. The 9 Cr 1 Mo (modified) steel was employed on later units for pipework.

The daily variation in load in Hong Kong required many large load changes. The Parsons unit benefited from the many years developing machines capable of fast starting and load cycling.

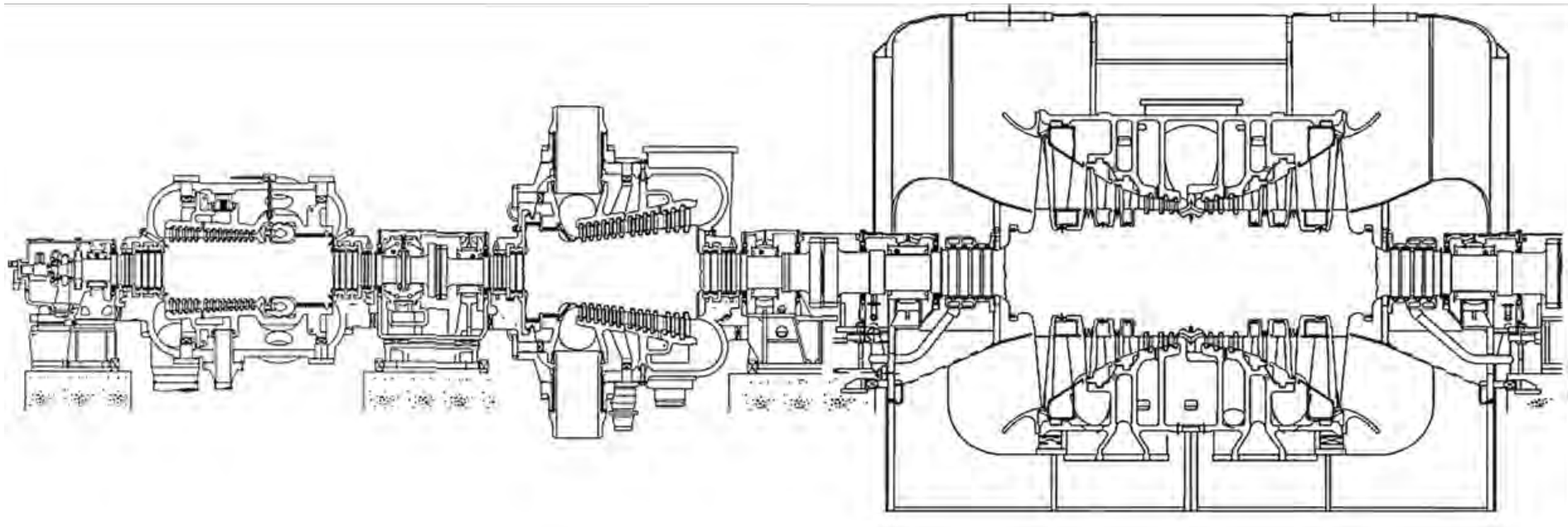

Fig.221 Lamma Island 350 MW 3,000 revs/min turbine 1989

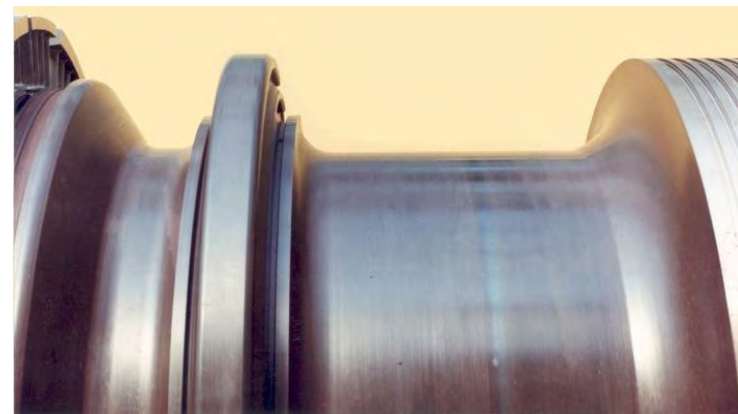

Fig.222 Comparison of the HP turbine rotor inlet geometry for Drax, *left*, and Lamma Island, *right*. The feature marked A was specified in the 1960s to allow the creep growth of rotors to be measured.

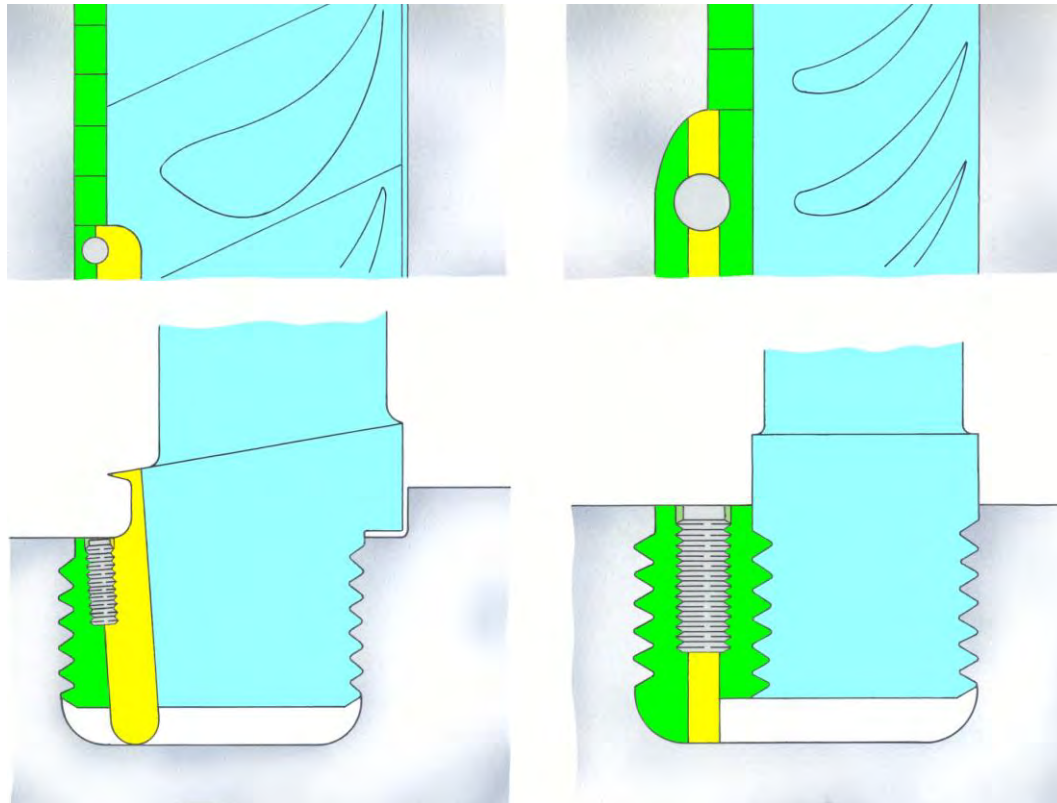

Fig.223 Comparison between the closing gate for R-series blades *left*, in which the locking pieces were accommodated in the blade segment rather than the rotor body and the closing gate for 600 series blades, *right*, which had to be cut into the rotor material resulting in a stress raiser.

An area of particular gain concerned the resistance to thermal fatigue. This mechanism affected the high temperature parts of the turbine where fillet radii and other stress raisers could cause the peak stresses during transient heating to exceed the yield strength of the material. Yielding increased the peak strains which occurred and produced adverse residual stresses and so was undesirable. Advantage was taken of the ability of computer numerically controlled (CNC) machine tools to optimise the geometry, lower the stresses and increase fatigue life. Figure 222 compares the inlet region geometry of the original Drax HP turbine rotors compared with Lamma Island. The Drax shafts were manufactured using traditional lathes where fillet radii had to be created by manually indexing a cutter. The Lamma Island shaft was machined on a CNC lathe where any desired geometry could be specified. On the inlet side of the dummy piston, the radius was increased from 1.25" (31.8 mm) to 150 mm which reduced the SCF from 2.2 to 1.3. The geometry of the region between the Rateau stage and the reaction stages was also refined. This had the effect of reducing the peak transient stresses below the yield strength and increased the fatigue endurance. Further to this, the wider pitch/chord ratio for R-series allowed the closing gates of the blading to be machined into the blade segments leaving the shaft body untouched, fig.223. This eliminated a further stress raiser. The permitted number of hot starts for Lamma Island was 10,000 rather than 4,000 as at Drax.

A new feature was introduced in the design of the HP turbine inner casing. A groove was machined in the face of the horizontal joint flange. This created distinct inner and outer contact faces for the joint. This allowed the force applied by the bolts to be concentrated locally and so smaller bolts were needed to keep the joint closed. This was helpful since the low pressure ratio across the control stage increased the wheelcase conditions to 2,030 lbs/in² abs 1008°F (140 bara 542°C) ie about 20 bar higher than past machines.

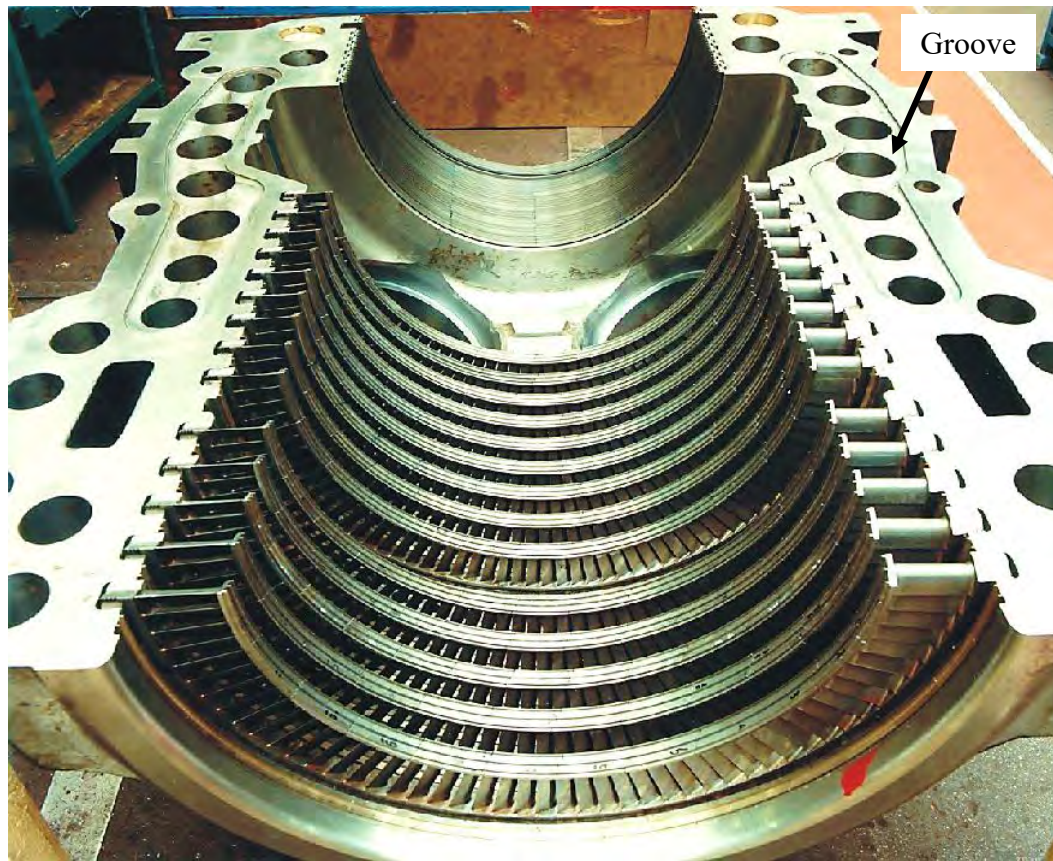

Fig.224 Lamma Island HP turbine inner casing looking from the exhaust end towards the inlet region showing the groove machined into the face of the horizontal joint

A new generation of steam chests was introduced during the 1980s starting with three 33 MW units for Morupule PS in Botswana, fig.225. These chests extended the desirable attributes identified in past designs to the greatest possible extent. The internal flow geometry was developed extensively to achieve maximum performance with low noise, low vibration valves. The steam valve chambers were completely separate from each other to minimise thermal stress. Stress raisers were practically eliminated. The valves were mounted close to the turbine to avoid the pressure losses associated with long loop pipes. Direct acting, high pressure hydraulic actuators were used to eliminate the lever systems employed on previous steam chests.

There were two aspects of the valves where Parsons showed conservatism, though. Firstly, the valves were not attached directly to the turbine casing due to concerns about potential cracking which had occurred in GEC Erith industrial steam turbines where the valves were incorporated directly in the turbine casing. Secondly, Parsons wasn't prepared to mount the hydraulic actuators vertically above the valve chambers. Hydraulic fluid leaks were not expected to occur, but if one happened by accident, then leaking oil falling onto a hot valve chamber could have started a fire. For this reason, the valves were mounted in positions where any leaking fluid would fall clear of the hot parts.

This arrangement appeared to be very attractive as implemented on Morupule and was given the shorthand name 'the compact steam chest arrangement'. It was decided to adopt valves of this style on Lamma Island and other large turbines.

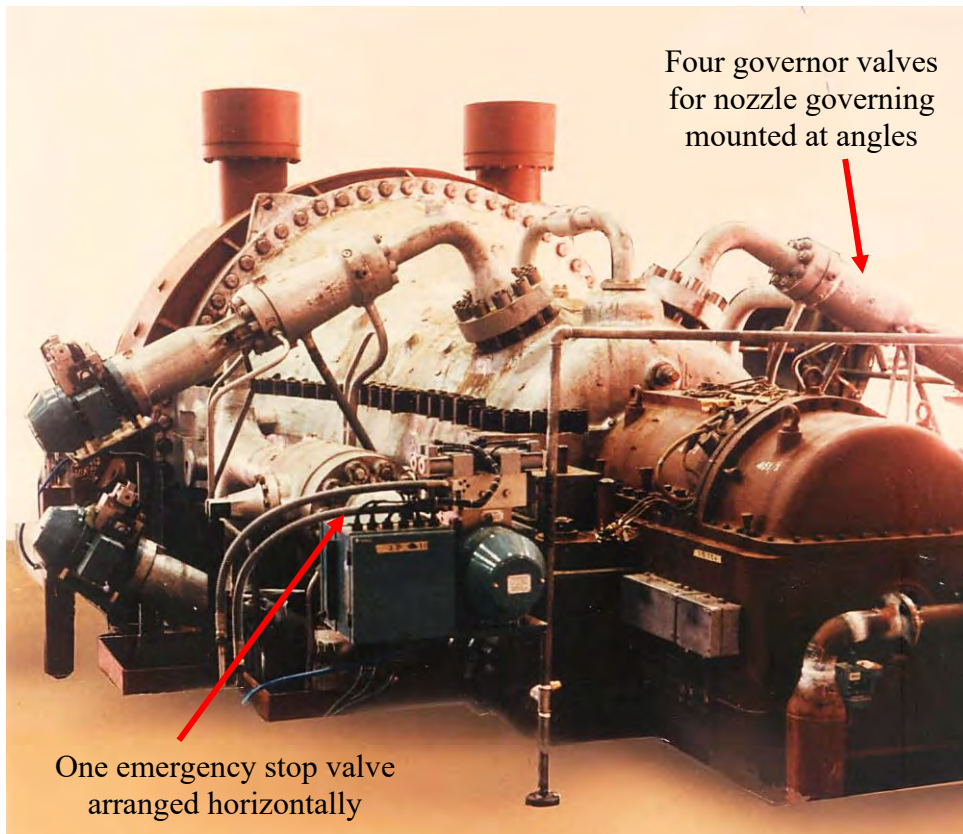
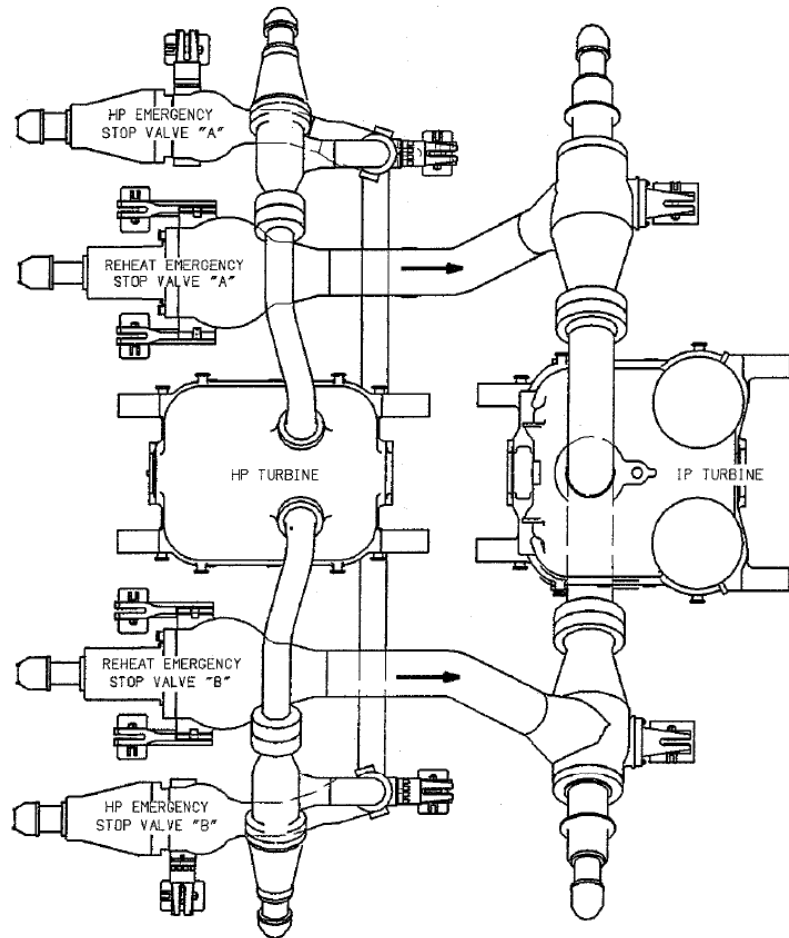

Fig.225 New steam chest design employed on three 33 MW non-reheat single cylinder turbines at Morupule

The Lamma Island valve arrangement is shown in fig.226a, b and c. Here the steam chests achieved all of the technical benefits as desired, but the arrangement looked to be oversized. The reasons for this were as follows. At 350 MW, Lamma Island needed 10 valve chambers: 2 HP ESVs, 4 HP governor valves, 2 reheat ESVs and 2 intercept valves. Just before Lamma Island was tendered, there was a trend within the industry to offer lower valve pressure drops. For Lamma Island, the valves were enlarged to increase the flow area and so reduce the steam velocities since pressure losses reduced with velocity squared. Parsons decided to use only two inlet pipes and two intercept valves on the IP turbine. With the increased size to reduce pressure losses, each intercept valve chamber was large enough for a person to stand inside without being visible from the outside. Finally, the turbine cylinders shrank in size due to the use of R series blading which gave the appearance of the valves being even larger in proportion. The physical size and arrangement now made the foundation block difficult to design. Should the valves be mounted inside or outside the concrete foundations? As shown in fig.226, it was decided to place the valves inside the foundation block which increased the civil engineering costs.

Once the valves had been built for Lamma Island and some contemporary stations, it was realised that technical purism had been taken too far. For subsequent machines, the steam chest style employed on Pulau Seraya stage I was employed but with larger internal valve throat diameters to maintain competitive, low pressure losses.



a Plan view

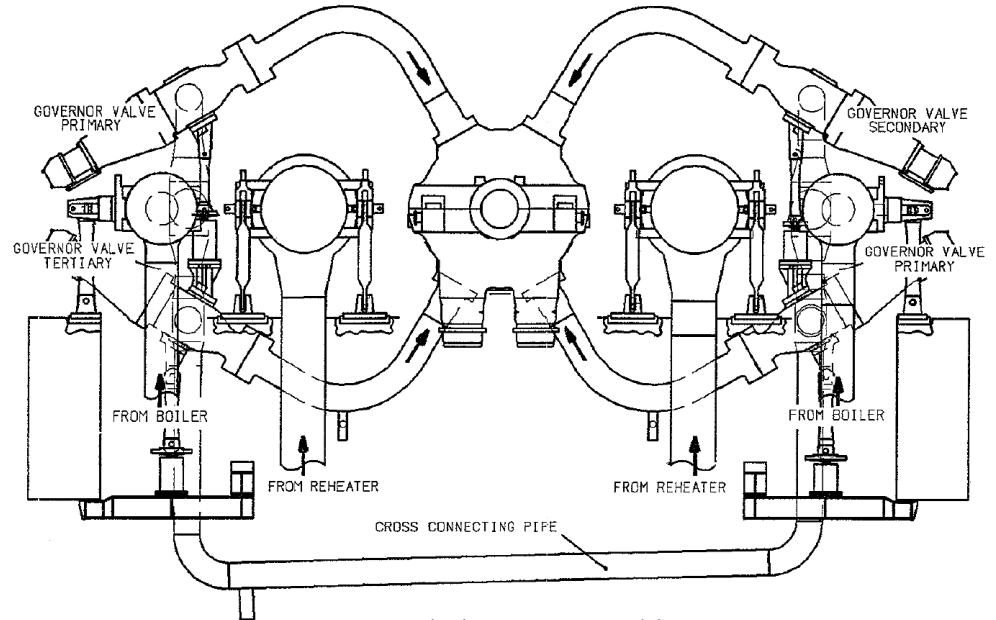

b End view on HP turbine

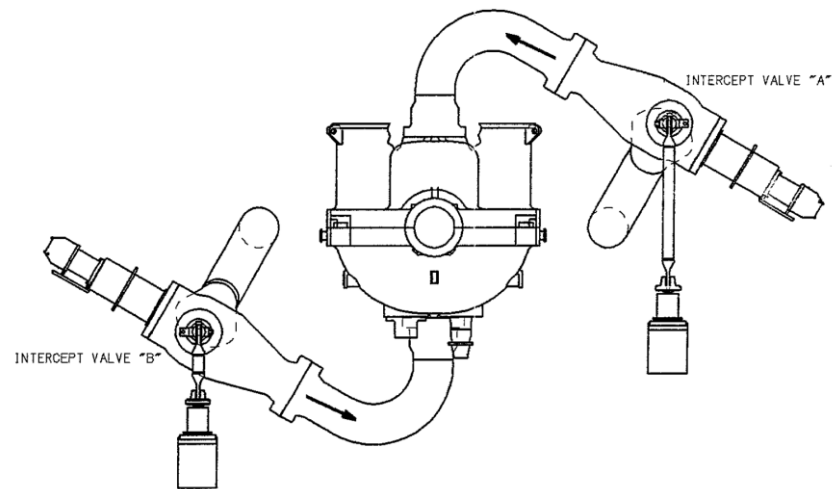

c End view on IP turbine

Fig.226 Lamma Island Unit 6 steam chest arrangement

The Rolls-Royce years 1989 to 1997

In 1989, NEI became part of Rolls-Royce and essentially formed the largest part of the R-R Industrial Power Group. For Parsons, this was a beneficial, non-threatening take-over since Rolls-Royce did not already have a steam turbine-generator business and there were many opportunities for synergy between the companies. As discussed later in this section, Rolls-Royce had developed 'three-dimensional' reaction blade technology which could be adapted to steam turbines, hollow titanium fan blades for aero-engines which allowed hollow LP turbine last stage blades to be developed, new types of blade seal and improved aerodynamic and mechanical design tools. Parsons provided expertise in manufacturing large components such as fan cases for the new Trent aero-engine and part of the Newcastle factory was dedicated to this.

Combined cycle plant

During the 1980s, power generation utilities started building combined cycle stations in significant numbers. These employed large industrial gas turbines (GTs) to produce electricity taking advantage of the GT's ability to operate at high turbine inlet temperatures. The low pressure ratio of the gas turbine (typically 20:1) extracted only part of the available energy and so the GT exhaust temperature was around 500°C or more. The exhaust heat was used in a boiler to produce steam for a steam turbine-generator. The ability of a steam turbine to work with a much higher overall pressure ratio then extracted further energy to achieve a combined cycle efficiency greater than 50% (far higher than a steam or gas turbine operating on their own). Parsons first combined cycle steam turbine was a 110 MW unit supplied to Connaught Bridge PS in Malaysia, fig.227.

The station employed two gas turbines and one steam turbine each driving separate generators. The rated stop valve conditions for the steam turbine were 38.0 bar abs 477°C.

The gas turbines at Connaught Bridge were supplied by another manufacturer. They did not possess any variable inlet guide vanes in their compressors or other features which in later plants helped to keep the GT exhaust temperature (and hence the corresponding steam temperature) approximately constant. In contrast, the stop valve steam temperature varied massively from 230°C at 30% load to 477°C at full load. This meant that the transient thermal stresses could be high during both starting and load changes especially since the gas turbines were capable of changing load rapidly. In addition, if both GTs were running at half load, and one GT tripped, the other would try to raise load immediately to full load causing a step change in steam temperature. This had to be regulated by the control system. Due to the risk of potentially severe thermal stresses, a fully double cased HP turbine was used so that the casing walls and flanges were relatively compact and the blade rings were kinematically supported ie able to expand freely in all directions.

Since the machine operated in sliding pressure mode once start-up was completed, there was no need for nozzle governing to achieve good part load performance, and so, all-reaction blading was used.

In addition, this station employed air cooled condensers with a rated condenser pressure of 0.19 bar abs which varied significantly with changes in ambient air temperature. This meant that tall last stage blades weren't needed because the volumetric flow at exhaust was relatively low, but the LP blades had to be rugged to withstand the buffeting which could occur in air-cooled machines.

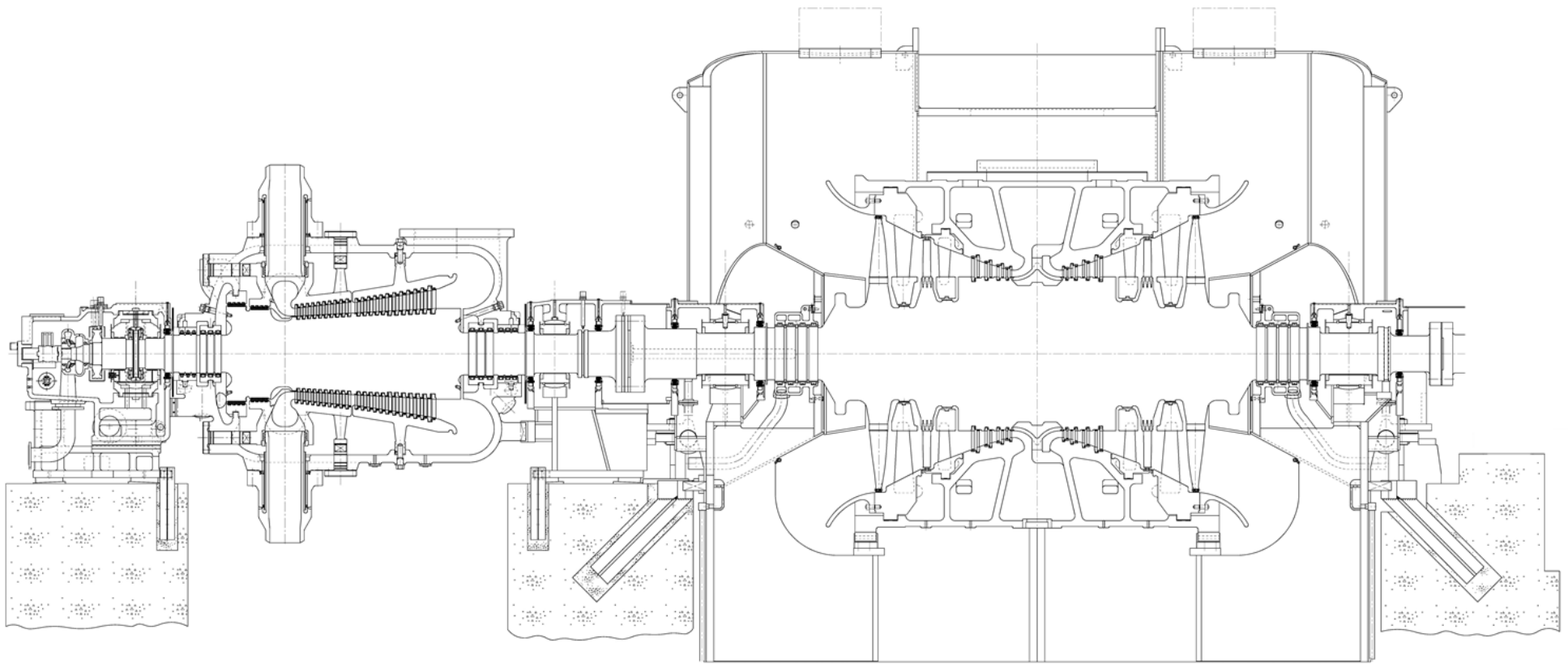

Fig.227 Connaught Bridge 110 MW 3000 revs/min turbine 1990

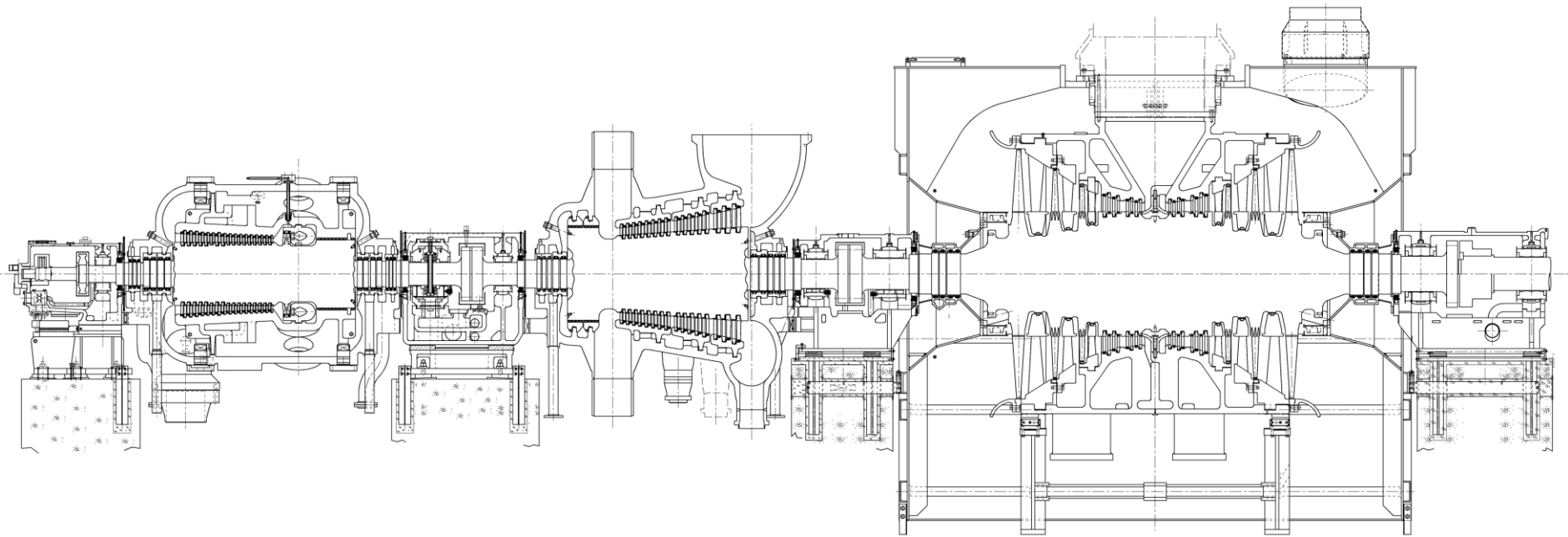

Fig.228 Budge Budge 250 MW 3,000 revs/min turbine 1991

Budge Budge PS, India and Pulau Seraya stage III PS, Singapore 250 MW at 3,000 revs/min

The next steps in development occurred in 1991 as follows, please see fig.228:

(a) HP turbine

The HP turbine was a standard module designed for applications up to 175 bar abs 540°C at the HP stop valve with an inlet volumetric flow up to 5 m³/sec.

The blade path was optimised for each application as follows. Customers normally advised the monetary rate at which the heat rate offered in each tender would be evaluated. In other words, customers were prepared to give credit to tenders which offered higher performance ie it was worth spending more on a turbine which was more efficient if the payback was high enough. For this reason, blading was designed on the basis of cost vs performance and not just performance alone. At the time of Lamma Island, the blade path computer programs automatically optimised the performance but the design engineer had to manually evaluate the cost. By 1991, detailed cost models were implemented in the blade path design programs so the software could optimise cost vs performance automatically. In addition, heuristic optimisation algorithms were developed in partnership with Newcastle University. Since there were many blade parameters which could be modified to obtain an 'optimum' solution, refinement of the optimisation algorithms was important.

The results were initially surprising. The software recommended using blade paths with many more stages on rotors of small diameter. This was unexpected for engineers who were used to optimising on the basis of a 'cost per stage' approach, which normally encouraged using short rotors of slightly larger diameter to reduce the stage count. It soon became clear that the computer results were logical from detailed costing. If a smaller diameter blade path was used, then the no. of blades per row reduced and this almost counteracted the cost of the extra stages. With blades operating at a lower diameter, the blade speeds were down, and at optimum stage loading, the corresponding steam speeds were also lower. The smaller diameter also required taller blades which reduced secondary losses and tip leakage losses. This gave a significant efficiency gain.

In addition, an improved heat rate could be achieved if the final temperature from the feedwater train was increased, so the option to provide a steam extraction from midway along the HP blade path was retained, but the no. of feedheaters was reduced by eliminating one of the IP turbine extractions to achieve a significant saving in cost.

In terms of construction, the principal change in the HP turbine was the adoption of alloyed nodular cast iron. Unalloyed nodular iron had been used for LP turbine inner casings since Pickering A in the 1960s. By 1991, grades of nodular cast iron containing 0.5% Mo to increase the high temperature properties were available. This cost of the material per tonne was 60% lower than ½ CrMoV steel and yet the properties were suitable for use up to 450°C. It was decided to employ alloyed nodular iron for the HP turbine outer casing starting with Pulau Seraya stage III. The only disadvantage was the fact that large structural welds could not be made with nodular cast iron, so the HP exhaust pipes had to be connected using bolted joints.

(b) IP turbine

The IP turbine was a standard module designed for applications up to 40 bar abs 540°C at the IP stop valve with an inlet volumetric flow up to 22 m³/sec.

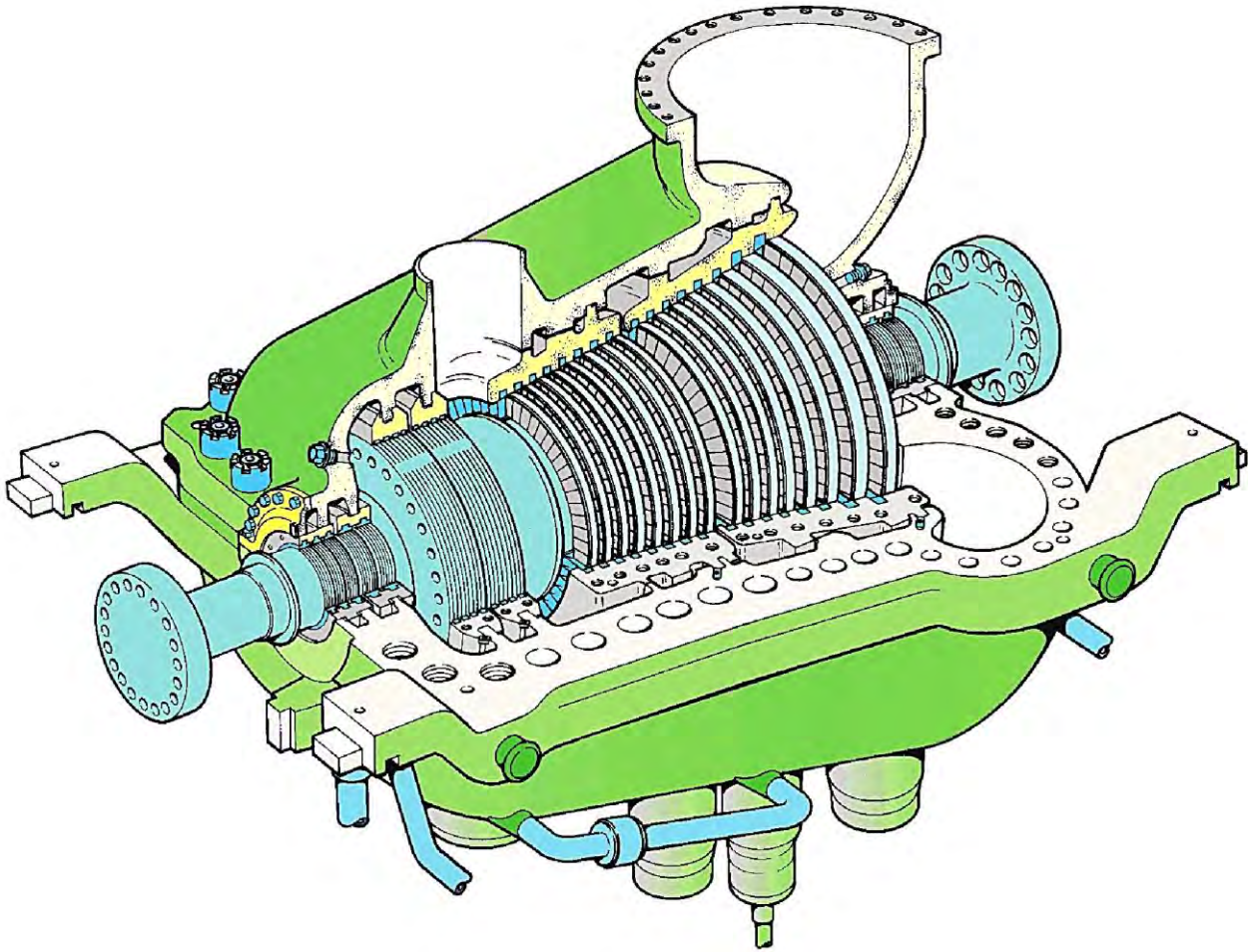

Fig.229 Pulau Seraya stage III IP turbine

In this design, fig.229, the outer casing carried the inlet pressure and temperature. This casing could therefore be optimised for this duty. The blades were mounted in separate blade rings. Each blade ring sealed against a groove in the outer casing at its downstream end. Consequently, the pressure surrounding each blade ring was higher than that inside which helped to keep the rings clamped shut. The horizontal joint bolts were less than half the size used on Lamma Island and this reduced the size of the flanges and the thermal inertia of the rings. The blade rings could be optimised to control the clearances of the blading without having to carry the main pressure and temperature loads.

Studies showed that there was a thermodynamic advantage from having a two stage balance piston as on previous machines, but not a stepped diameter. The balance piston was therefore a single diameter design which allowed the seals to be standardised.

(c) LP turbine

Further refinements in bladepath analysis raised the performance. For example, the three LP turbines at Pulau Seraya stage III achieved an average LP turbine efficiency of 97.3% (evaluated on a 'dry excluding leaving loss' basis) which was approximately 3% higher than the stage I units.

In terms of construction, the LP turbine rotor bearings were mounted directly on the foundation block rather than being carried in the exhaust hood as on previous turbines. This eliminated the slight change in LP rotor centreline height which occurred when the pressure changed in condensers connected using flexible bellows to the turbine. By removing the weight of the shaft train from the LP turbine outer casing, the casing fabrication could be made lighter to save cost.

Otherwise, the LP turbine retained the principles which worked well on earlier designs with detailed improvements such as one rather than two IP-LP cross-over pipes, fig.230, and arched hoop springs rather than helical springs for some of the bladepath seals.



Fig.230 One of the units in Pulau Seraya stage III turbine hall before fitting the acoustic covers

Blading development using Rolls-Royce technology

(a) Three dimensional reaction blades

The presence of secondary losses in short blades had been known for many years. These were related to the formation of vortices in the flow close to the inner and outer boundaries due to pressure differentials within the blade passage. During the 1990s, it was possible to analyse these mathematically and develop solutions. For example, fig.231a shows a photograph taken on a 600 revs/min air turbine built by Parsons at Cambridge University Whittle Laboratory. Oil films revealed the extent to which these vortices could disturb the flow. Fig.231b shows the predicted flow vectors from a CFD analysis. In this case, only flow vectors at 90° to the desired direction are plotted ie the vectors revealed here were unwanted.

Rolls-Royce had developed techniques to suppress these vortices and improve the performance of the blades. Their approach was adopted at Heaton Works and this led to the design of 'three dimensional' reaction blades. The term three dimensional usually refers to the use of taper, twist, lean and bend along the blade length. To reduce secondary losses, the most significant change was to increase the blade throat opening close to the inner and outer flow boundaries. Whereas

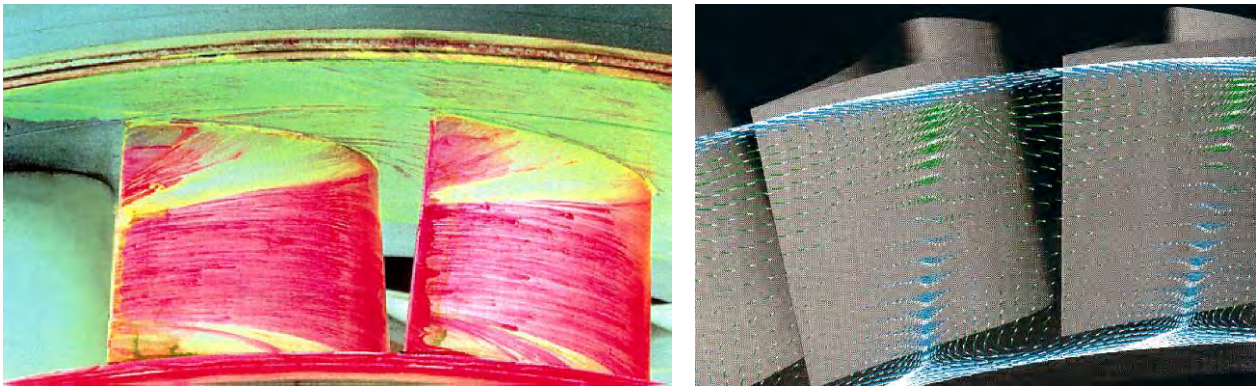

Fig.231a Oil film visualisation of secondary flow effects in a large air turbine at Cambridge University, *left*, and fig,231b CFD analysis results showing flow vectors at 90° to the desired flow direction, *right*



Fig.232 A 3D reaction blade using ‘end bends’ in the trailing edge to increase the blade throat opening close to the hub and tip to suppress flow vortices

some manufacturers did this by bowing the entire blade, the Rolls-Royce technique involved applying ‘end bends’ over approximately one third of the blade height at the hub and tip, fig.232. This was very effective. Together with other aerofoil refinements, 3D blades achieved an efficiency gain of up to 2% relative to uniform section R series [36].

The first use of these blades was in upgrades for 660 MW HP and IP turbines at Heysham and Hunterston power stations, figs.233 and 234.

These 3D blades became the preferred design for Parsons since they could match or beat the performance of any other manufacturers’ turbine.

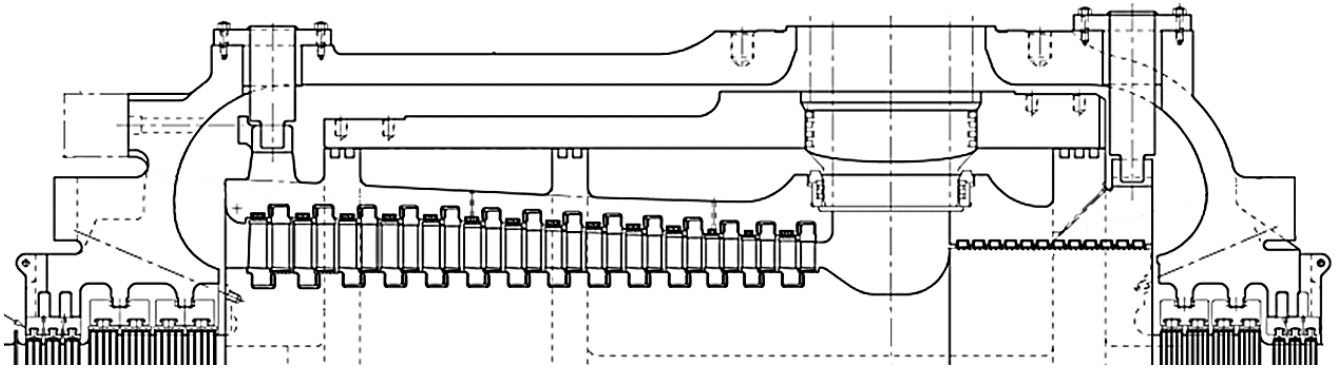

Fig.233 Upgrade for Heysham HP turbine in which the rotor and inner casing were replaced to eliminate the original Rateau stage, change the stage count to improve the stage loading and implement new aerofoils and tip seals.

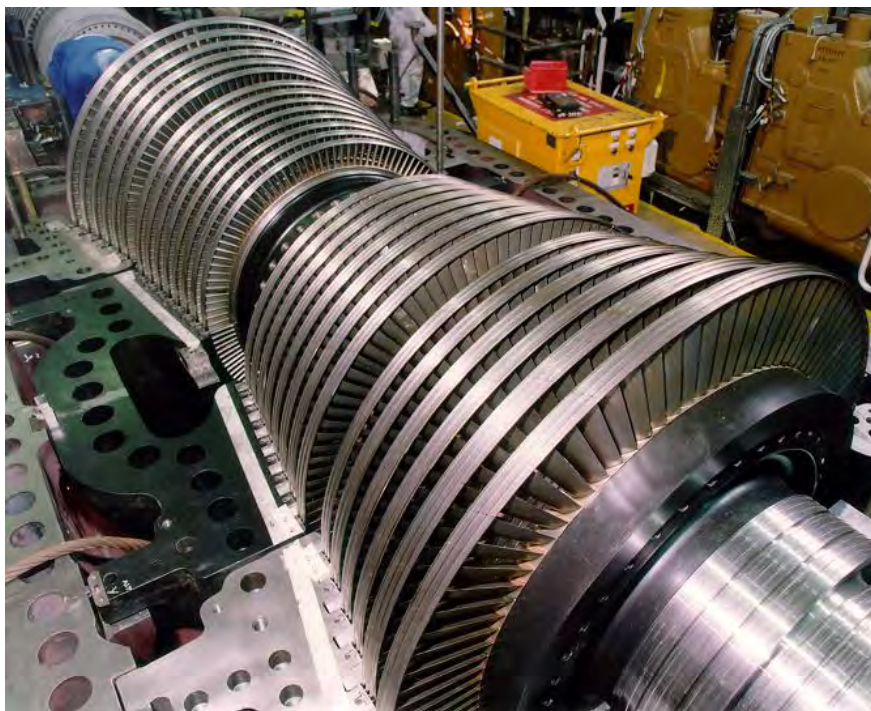

Fig.234 Upgrade for Hunterston IP turbine in which the rotor, inner casing and blade rings were replaced to change the design from impulse to 50% reaction blading with the latest aerofoils.

(b) Aero-engine blade tip seals

For around 100 years, steam turbine blade tip seals had relied upon interleaved sealing fins to create a complex labyrinth to resist leakage flow. Rolls-Royce had developed three types of seal which used a different approach.

Abradable seals – A special coating was applied to the seal insert in the casing, fig.235a, so that the sealing fins on the moving blade shroud could cut their own clearance in service and so work with a smaller radial clearance than a traditional labyrinth. These were installed in selected stages in Connaught Bridge HP turbine. There was a concern that if used on every blade row, then the extra drag on the shaft during barring would require an excessively large turning gear motor. This concern was unfounded but it delayed the wider use of abradable seals until the early 2000s when Parsons was part of Siemens.

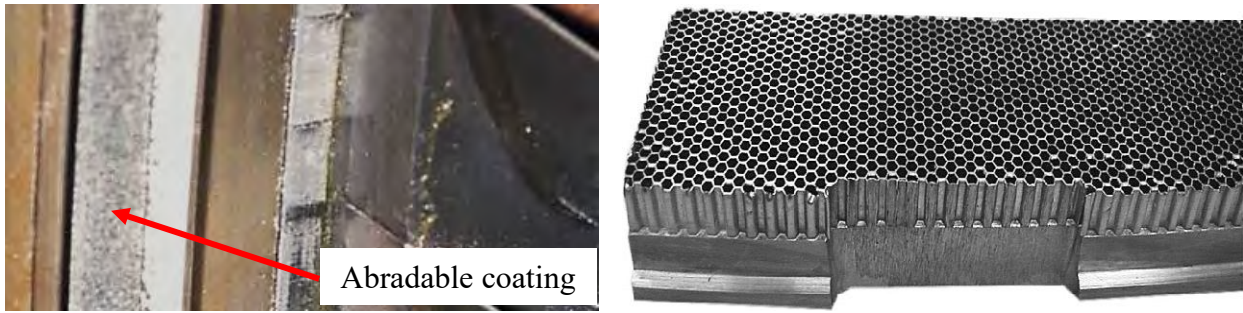

Fig.235a An abrasible seal installed in Connaught Bridge HP turbine, *left*, and fig.235b a honeycomb seal insert for LP turbines, *right*

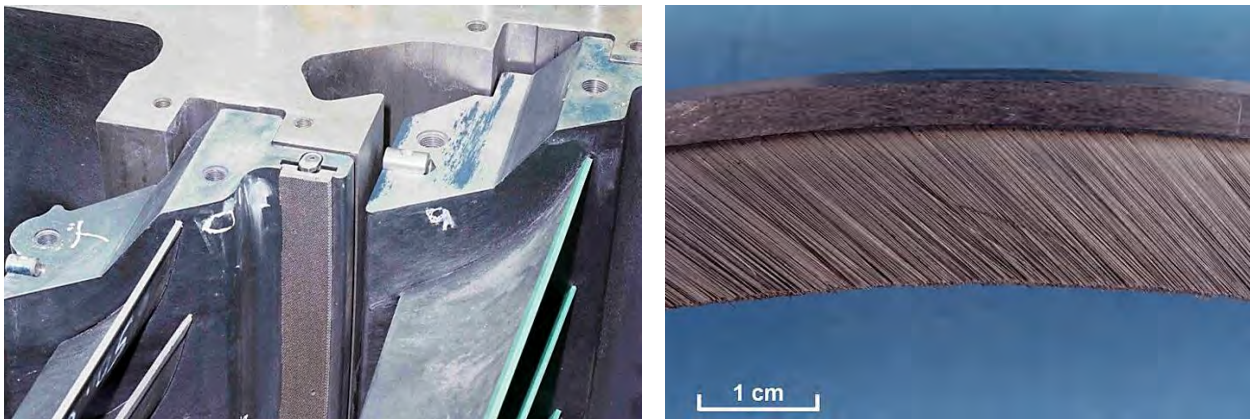

Fig.236a Honeycomb seal installed in an LP turbine diaphragm, *left*, and fig.236b close up view of the bristle pack of a brush seal, *right*

Honeycomb seals – These comprised a superalloy matrix (the honeycomb) brazed to a steel backing plate, fig.235b, and were considered to be suitable for LP turbine stages, fig.236a. In a similar way to abrasible seals, these allowed the blades to cut their own clearance. They were used in many units but were subsequently discontinued when it was found that boron contained in the braze could act as a catalyst and harden the honeycomb matrix.

Brush seals – These seals employed a set of superalloy bristles sandwiched between a narrow front plate and a larger, supporting back plate. The bristles were inclined at an angle to the rotating surface such that the fluid entrained on the surface lifted the bristles in service to form a clearance typically only one tenth the size of the clearances in a traditional labyrinth. The key issue was the maximum pressure differential which the bristles could withstand before folding back and disabling the seal. In the 1990s, the limit was around 10 bar which was satisfactory for an aero-engine but not a steam turbine. Brush seals for steam use matured in the 2000s when they could carry much higher pressure differences. Seals of this kind were then adopted for blade shroud seals.

All of the new seal types held great potential but they did not become effective until Parsons and Westinghouse became part of Siemens and the technologies of the three companies were combined and the best version implemented.

(c) Hollow titanium last stage blades

Rolls-Royce had developed hollow titanium fan blades for aero-engines starting in the 1970s, fig.237. These had provided a key advantage which other aero-engine manufacturers had found hard to beat. It was considered possible to adapt this technology to a 1200 mm long last stage LP turbine blade. A steam turbine blade was comparable in length to a Trent fan blade and ran at a lower speed but was mounted on a larger diameter.



Fig.237 A hollow titanium fan blade from a Trent aero-engine compared with a typical Parsons steel LP last stage blade

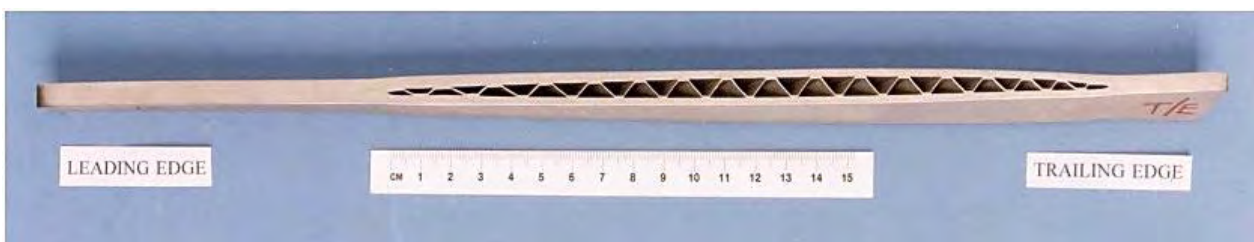

Fig.238 Cross-section through the hollow aerofoil showing the diffusion bonded, super-plastic formed blade at a stage before finalising the aerofoil shape.

The blade was to be manufactured by fusing three layers of titanium together – two thick and one thin layer – using a special coating to ensure the alloy fused only where desired, fig.238. The aerofoil was then inflated using gas pressure to create the desired aerofoil shape with an internal zig-zag lattice. Trials demonstrated that the blade would have sufficient resistance to water droplet erosion simply due to its inherent hardness without a special hardening process or an erosion shield. The cost per blade was much higher than a steel blade but with only 34 blades per row compared with around 70 for a contemporary steel blade, the cost per row was similar. The hollow aerofoil combined with the lower density of titanium reduced the centrifugal forces in the

blade and so allowed greater freedom to optimise the aerofoil shape. In addition, the blade was entirely free standing. Further, there was no need to taper the aerofoil from hub to tip, so the blade was 400 mm wide along its entire length which enabled a much improved blade passage shape to be designed towards the blade tip. The blade also used a single dovetail root fixing which was structurally better than the Parsons fir tree root fixing.

Aerodynamically, the blade provided a much higher stage efficiency than conventional steam turbine blades and it was anticipated that other steam turbine manufacturers would not be able to match it (except perhaps General Electric which was also an aero-engine builder). It was offered to the market just before the take-over by Siemens and attracted a lot of interest.

To make the blade suitable for operation at a much larger diameter than the Trent engine, the aerofoil was 40% hollow rather than 60% hollow as on the fan blade, fig.239. This was fine for a blade 1200 mm long. However, it was known that another manufacturer had a longer, solid titanium blade. To increase the length of the Rolls-Royce blade, the aerofoil would become progressively less hollow until it also became a solid design. There were questions therefore regarding how far this technology would go. The development was superseded once Parsons joined Siemens in 1997, since Siemens already had a steel blade similar in size to the hollow 1200 mm design as well as longer, solid titanium designs. Combined with this, manufacture of the hollow blade was intended to be carried out at Rolls-Royce's Barnoldswick factory, and this option became unavailable once Parsons left Rolls-Royce.

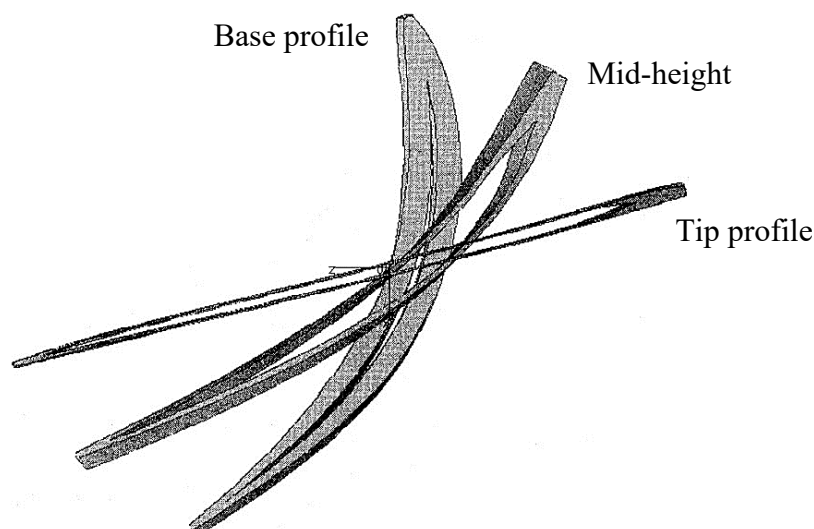

Fig.239 Drawing illustrating the extent of the hollow cavity inside the 1200 mm titanium blade

(d) High twist blade development

Development of high twist blades continued in parallel with the topics described above especially blades for upgrading other manufacturers machines. A key development was the use of laser hardening to transform the material structure of the parent 12 Cr steel, so that last stage LP blades could withstand water droplet erosion without the need for a brazed-on erosion shield. In addition, the Rolls-Royce finite element software SC03 was used for blade stress and vibration calculations. This program was so reliable at predicting the vibration frequencies of high twist blades, it was found that it was no longer necessary to build a test wheel to confirm the frequencies. This saved considerable development time and cost. If a customer required vibration measurements for a given contract, these were taken from the finished production turbine rotor while it was in the vacuum balancing chamber.

Joint turbine development with Westinghouse

In 1992, Westinghouse and Rolls-Royce signed an agreement to share gas turbine technology; in particular, implementing aero-engine technology in large industrial gas turbines. Parsons learned of this and asked for this to be extended to cover combined HP/IP steam turbine technology also.

Parsons had not designed a combined HP/IP turbine before. There were a number of reasons for this as follows:

- The pressure in the HP inlet belt was normally four times higher than in the IP inlet. So, even though both inlets operated at the same temperature at steady full load, during starting the HP section heated up faster than the IP section due to higher heat transfer coefficients. In the 1970s, for example, full 3D finite element analysis of the transient heating of a complete casing structure was impracticable. This meant that casing deflections and ovality during transient heating could not be predicted and so it would have been necessary to specify conservative radial clearances. It was estimated that the use of oversize clearances compared with separate HP and IP cylinders would have sacrificed at least 0.25% on heat rate, which couldn't be tolerated in Parsons markets, plus there was a risk of rubbing.
- In a combined HP/IP turbine, it was necessary by definition to use a single flow IP blade path. When combined cylinders came into widespread use in the USA during the 1950s and 60s, relatively high IP-LP cross-over pressures (typically between 10 and 15 bar abs at full load) were adopted to allow single flow IP blade paths in large machines. These pressures subsequently became established as a norm and customers' architect engineers specified these pressures in tender specifications, which restricted the manufacturers freedom to deviate. European manufacturers did not suffer this restriction. Architect engineers did not specify the IP-LP cross-over pressure in other markets and it was left to the turbine manufacturer to optimise this. This led to cross-over pressures typically in the range 3 to 8 bar abs which gave a performance advantage but required more stages in the IP blade path. Parsons didn't want to compromise on the cross-over pressure.
- In addition, a low IP-LP cross-over pressure usually required three feedheat extractions from the IP blade path. This would have been hard to arrange in a combined cylinder.

By the 1990s, full 3D analysis of casings was possible. In addition, there was a strong market demand for units of 250 MW rating for which a single flow IP blade path with a low cross-over pressure seemed practicable. While Parsons could have designed a combined HP/IP turbine, the likely reaction of the market was uncertain – who would buy a turbine from a manufacturer with no prior experience of combined HP/IP cylinders? For this reason, it was considered to be a more sensible approach to establish a relationship with Westinghouse who had many decades of experience designing combined cylinders and had a massive fleet of machines with combined HP/IP turbines already in service. Westinghouse agreed to the proposal to work together.

To ensure that both parties considered that they were getting a satisfactory payback from the partnership, it was initially proposed that each company should exchange individual technologies from their research & development or design history. The original cost of developing each technology was unimportant provided that the current day value of the offered packages of information were comparable. Short lists of topics were compiled on each side and information on three different technologies at a time were exchanged. It was initially thought that there would be considerable duplication in the topics each company had investigated and developed, but this proved not to be the case. There was considerable scope for technology exchange, and between 1992 and 1994, it was found that the exchange couldn't occur fast enough. To speed the process

up, it was proposed in 1994 that the two companies should undertake joint development of turbines by placing engineers in a joint team in the Westinghouse Engineering offices in Orlando, Florida or in Newcastle taking turns with each new project. The first project was a combined HP/IP turbine which Westinghouse had already started and is shown in fig.240. This module was designed to suit 350 MW applications with a high cross-over pressure and 250 MW units with a lower European cross-over pressure.

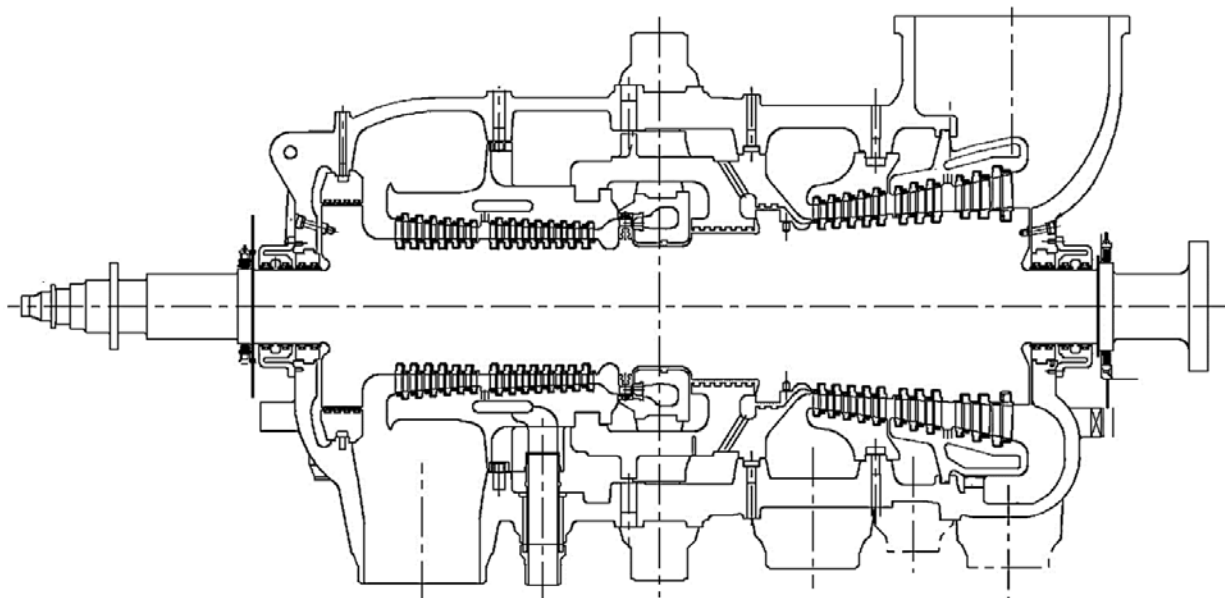

Fig.240 Combined HP/IP turbine for 250-350 MW applications at 3,000 revs/min with HP stop valve conditions up to 175 bar abs 540°C based upon a Westinghouse casing design with Parsons blades installed

This design employed a casing arrangement which was already proven in the Westinghouse fleet and used multiple blade rings both for ease of manufacture and to accommodate the casing movements which could occur in service. Fig.240 shows the machine with a Parsons bladepath installed for 250 MW applications. The last IP blade ring shows the solution for the required number of steam extractions. The HP bladepath retained a Rateau inlet stage for nozzle governing.

Letters of intent for 7 units of 250 MW were received quickly with another 4 units anticipated to be ordered shortly after. This occurred when Rolls-Royce had already decided to sell Parsons to Siemens and so the work was halted as the sale process commenced.

Council Bluffs HP turbine upgrade 726 MW at 3,600 revs/min

A notable machine was the upgrade for a General Electric 726 MW unit at Council Bluffs PS in the USA. The original HP turbine was an impulse turbine with a double flow control stage followed by Rateau stages in a single flow. The Parsons design, fig.241, employed reaction blades in a single flow arrangement, installed by changing the rotor and inner casing.

Using the principles of dynamic scaling, a 726 MW turbine at 3,600 revs/min was equivalent to 1,045 MW at 3,000 revs/min, so this was a highly rated design. HP stop valve conditions were 2,400 lbs/in² gauge 1000°F (165.5 barg 538°C). It was decided to use an all-reaction bladepath for peak efficiency. Special care was taken to minimise stress raisers at thermal fatigue sites. For example, the mid-blade path balance weight plane of the original machine was retained, but the

balance weight holes were formed in a dummy blade groove since this suppressed the stress concentration factor.

This turbine was one of the most efficient HP upgrades built by any manufacturer at the time it was commissioned.

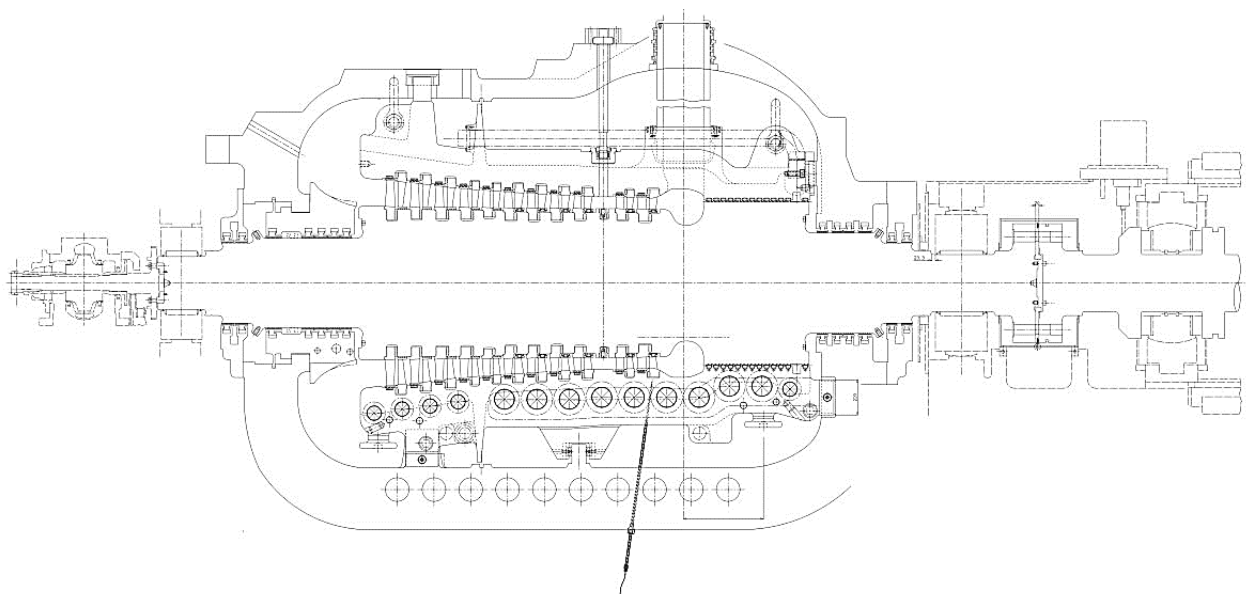

Fig.241 Parsons 726 MW 3,600 revs/min HP turbine upgrade installed at Council Bluffs

Other turbine types

Single cylinder turbines

Smaller turbines have not been described so far because they generally employed smaller versions of the technology used for large machines. For non-reheat units of 30 to 100 MW at 3,000 revs/min, a two cylinder turbine was often used due to the difficulty in achieving both satisfactory HP and LP rotor properties in a single cylinder turbine shaft. This changed in the 1980s.

For machines operating above 500°C, it was believed that the rotor steel should have the creep resistance of 1 CrMoV steel in the inlet region while possessing a sufficiently high tensile strength and fracture toughness at the exhaust end to carry the last stage LP blades. Conventional 1 CrMoV steel could be heat treated to increase its creep strength while reducing its fracture toughness, or vice versa, the toughness could be increased at the cost of creep strength. A satisfactory combination of strength and toughness could not be achieved for large turbines, so Parsons developed a variant in which the nickel content was raised to a minimum of 0.7% and the molybdenum content was raised slightly. This maintained the 200,000 hour creep strength of 1 CrMoV (which was 162 MPa at 500°C) while raising the toughness at the exhaust end from 40 to 66 MPa m^{1/2} at 20°C. This steel was used for the single cylinder 33 MW turbines at Morupule, fig.242.

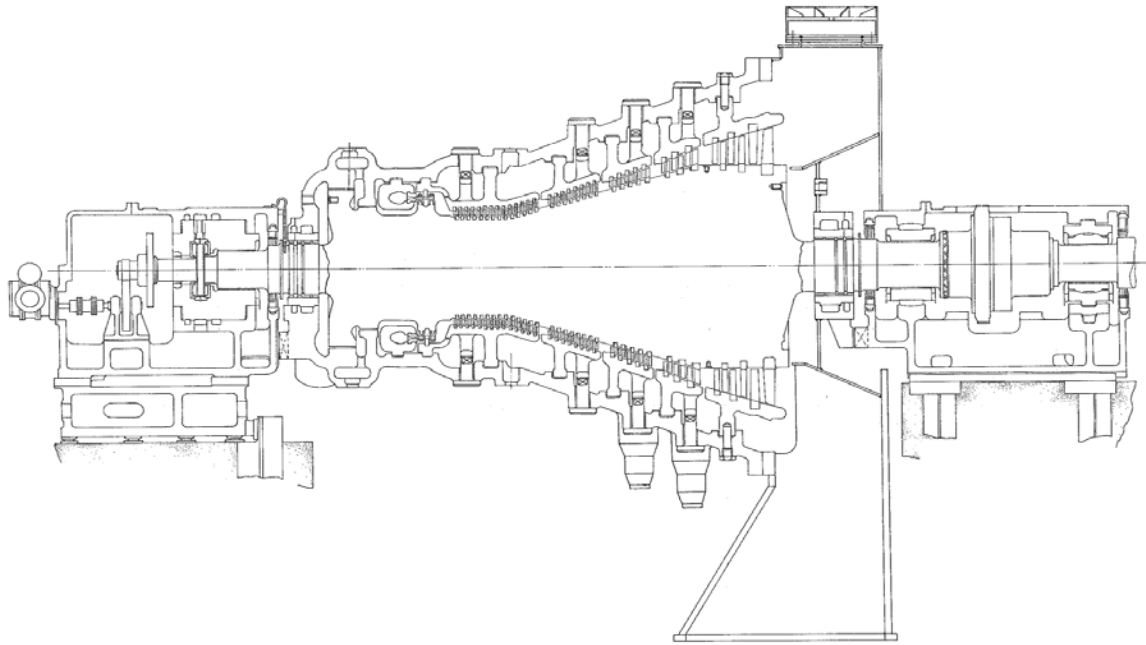

Fig.242 Morupule 33 MW 3,000 revs/min turbine 1983. Stop valve conditions were 85 bar gauge 510°C. The condensers were air-cooled with a normal working range from 0.15 to 0.40 bar abs.

For a while, the industry became interested in ‘super clean’ NiCrMoV. In other words, this was an LP turbine rotor steel capable of carrying large last stage blades with very low phosphorus and sulphur levels to suppress temper embrittlement. Some manufacturers employed this steel, but Parsons declined for two reasons. Firstly, the creep properties weren’t sufficient, and secondly, a better candidate steel was identified.

By 1990, a superior steel became available from European forgemasters especially Saarschmiede. This was a 2 CrMoNiWV steel which was heat-treated differently at the inlet and exhaust ends to obtain a better combination of properties in one shaft. The rotor forging was designed with a distinct step between the HP and LP blade path sections at a position where the steam pressure was low (typically 4 bar abs), fig.243. This reduced the end thrust from the rotor body compared with a continuously tapered forging and it was ideal for the heat treatment process.

Steels of this type had been studied in most countries. In the USA and Japan, a close variant was adopted where each end of the rotor forging was heated to different temperatures then quenched at different rates to produce the desired high creep strength at the inlet end and high tensile strength and toughness at the exhaust end. At Parsons, this approach seemed to be too complex and prone to possible variances. Instead, a European 2 Cr steel was employed in which the entire rotor forging was heated to a uniform temperature and then the steel was quenched at different rates at each end. This appeared to be a more dependable approach. It maintained a satisfactory creep strength and raised the exhaust end toughness to 110 MPa m^{1/2} at 20°C. This steel was first used for a 45 MW fossil-fired turbine at La Collette PS in Jersey, fig.244, and a 70 MW combined cycle turbine at Godavari PS in India.



Fig.243 Dual heat treated 2 CrMoNiWV steel rotor for La Collette

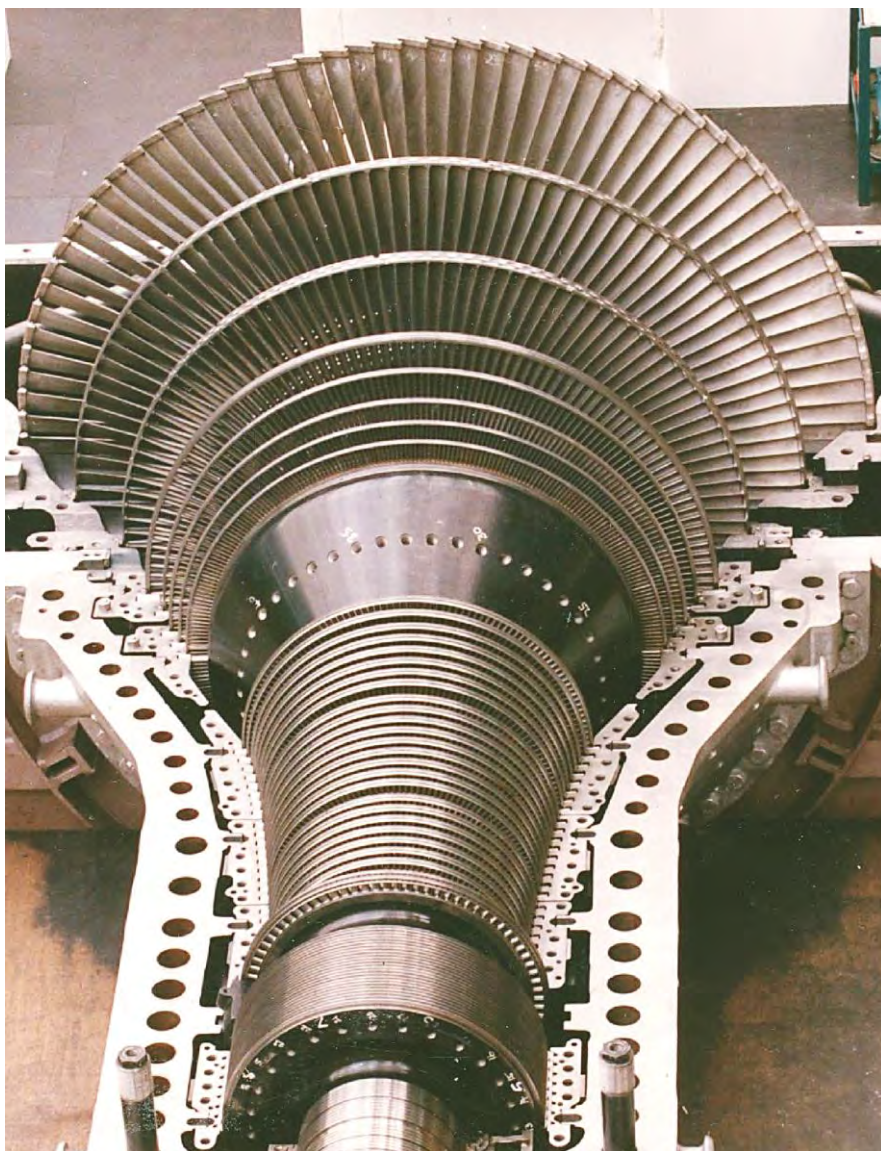

Fig.244 La Collette 45 MW 3,000 revs/min turbine 1992

This turbine employed a Rateau inlet stage for nozzle governing rather than the Curtis stage used in most previous small Parsons turbines plus HL high stage loading reaction blades.

HP, IP and LP turbine upgrades designed in Newcastle for manufacture under licence in China

During the 1990s, a contract was won to design upgrades for LMZ-type 300 MW 3,000 revs/min turbines in China. As usual, the upgrade involved installing new HP, IP and LP turbine rotors and HP and IP inner casings with a diaphragm swap in the LP turbines. This was expected to raise the performance of the turbines and increase the availability of the machines from around 77% to over 97%. For the HP and IP turbines, the appropriate designs were a derivative of the Lamma Island designs. These converted these cylinders from impulse to reaction blading.

For the LP turbines, the best solution was to develop modern 3D impulse blades, fig.245. This was the first time that Parsons developed CFD blades for a large impulse turbine and proved to be successful. The new turbines were manufactured under licence by one of the major turbine-generator companies in China. Many stations were upgraded commencing with Jianbi PS.

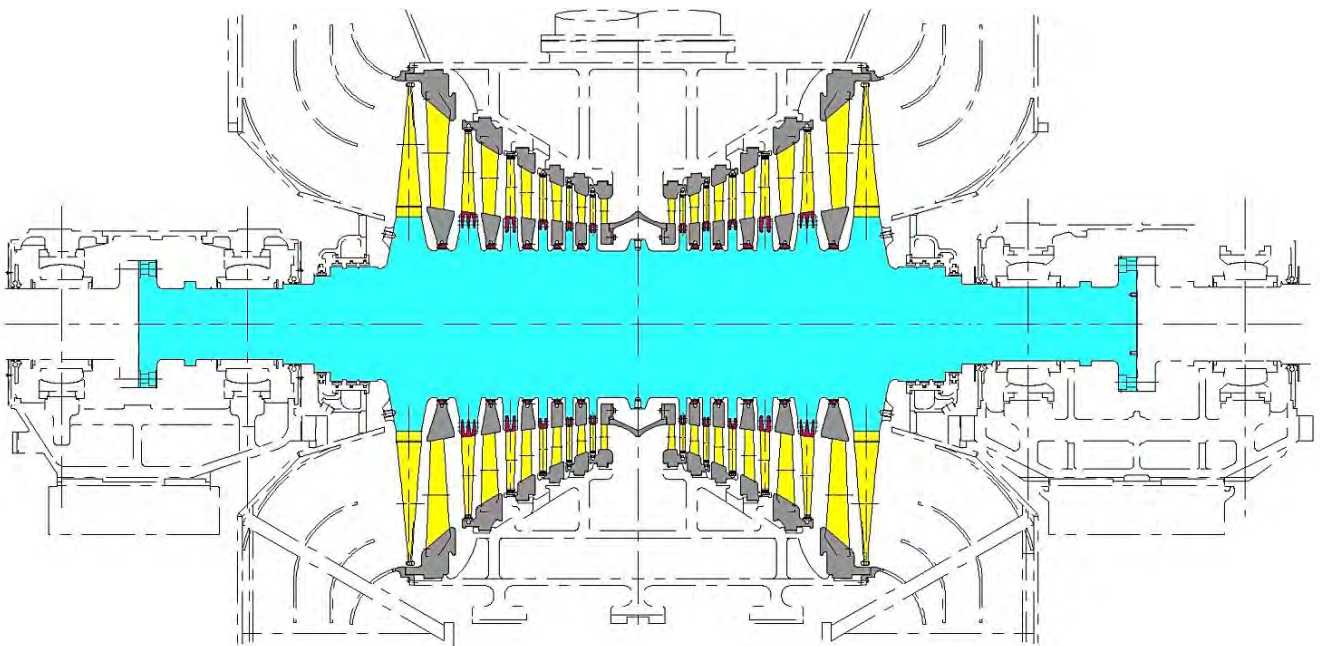

Fig.245 300 MW 3,000 revs/min LP turbine upgrade for China using modern 3D impulse blades

Parsons and Westinghouse become part of Siemens

In 1997, Parsons became part of Siemens followed by Westinghouse in 1998. This provided the opportunity to study and select the best technologies from the constituent companies. Siemens was building fossil-fired turbines to over 1000 MW at 3,000 revs/min with supercritical steam conditions up to 300 bar abs 610°C and nuclear turbines up to 1700 MW at 1,500 revs/min for pressurised water reactors. The change to much higher conditions and power outputs combined with a detailed study of the individual technologies eg free-standing LP turbine blades vs Parsons blades which required a tip strut resulted in most aspects of Parsons technology becoming discontinued apart from spares and servicing support for the existing fleet. Heaton Works was renamed as CA Parsons Works in honour of Sir Charles and it remained as one of the main turbine-generator plants in the Siemens family, but the technologies used changed to Siemens designs because this was necessary for higher operating conditions or they provided an advantage in conventional applications.

Summary

Sir Charles Parsons pioneered the development of the World's first steam turbine-generator and the marine steam turbine. To do this, he overcame many challenges. This included producing designs which enabled machines to run at very high speed, raising their efficiency to exceptional levels, establishing companies to develop and manufacture turbine-generators, finding financial backing, developing new manufacturing methods and promoting the new technologies to an industry which had never seen them before. He was successful in this, and saw the steam turbine become the dominant engine for power generation. He continued to push the development of turbine-generators until they produced very high power outputs, a major step which enabled electricity to be provided to everyone, not just the privileged few, at affordable prices.

After his passing, his company CA Parsons & Co Ltd continued to pursue the development of turbine-generators. After World War II in particular, there was a rapid growth in machine size from 50 MW to 800 MW operating at much higher steam conditions with more efficient steam cycles. Under the leadership of Sir Claude Gibb, the company grew threefold in size and subsequently reached a peak of 12,500 employees. Sir Claude also saw the importance of developing machines for nuclear power generation, gas turbines and other technologies. This led to the creation of many daughter companies to develop these technologies, consortia to build nuclear power plants and companies to provide the materials and components which were needed. This helped to maintain Parsons as one of the World's leading turbine-generator companies.

From 1965 onwards, there were many acquisitions and mergers commencing with the takeover of the turbine-generator business of GEC and the formation of Reyrolle-Parsons. There were then many further changes in the company organisation to provide technical or business advantages including the creation of Northern Engineering Industries, joining Rolls-Royce, a partnership with Westinghouse and finally becoming part of Siemens. The company which Sir Charles Parsons established still exists within the Siemens family and is still designing and developing steam turbines for power generation.

Since 1884, the company has been responsible for many historic achievements including numerous machines which were the first of their kind, the most powerful in their day, the most efficient and units with the highest availability. Work is in progress to document the history of Parsons and place this in the public domain. This paper has described the nature of the technology of the most powerful and advanced steam turbines as they developed over the years with an insight into the reasons for change. This is the first document to be produced and will be followed by further information in the future.

Acknowledgements

The author would like to thank Siemens for permission to publish the paper.

References

1. A Richardson, The Evolution of the Parsons Steam Turbine, 1911, Engineering
2. R Appleyard, Charles Parsons, His Life and Work, 1933, Constable & Co
3. RH Parsons, The Development of the Parsons Steam Turbine, 1936, Constable & Co
4. WG Scaife, From Galaxies to Turbines: Science, Technology and the Parsons Family, 1999, Institute of Physics/CRC Press

5. The First 500-Kilowatt Curtis Vertical Steam Turbine, ASME booklet 23rd July 1990, www.asme.org
6. JF Wasik, *The Merchant of Power*, 2006, Palgrave Macmillan
7. JR Bolter, Sir Charles Parsons and electrical power generation – a turbine designer’s perspective, 1994, *IMEchE Journal of Power and Energy* p 159-176, 59th Parsons Memorial Lecture
8. 50,000 kW Parsons reaction turbo-alternator for the Crawford Avenue Power Station of the Commonwealth Edison Company of Chicago, *Engineering*, 5th March 1926
9. A Sherry, The power game - the development of conventional power stations 1948 - 1983, *IMEchE James Clayton Lecture* 25 April 1984
10. JM Hodge and IL Mogford, UK Experience of stress corrosion cracking in steam turbine discs, 1979, *Proc IMechE Vol 193* p 93-109
11. A Howell and JB Jackson, The design and operation of Dunston B generating station with particular reference to 50 MW turbo-alternators unitized with reheater boilers, 1952, *Proc IMechE vol 166* p.401
12. Merrill Denison, *The People’s Power*, 1960, McClelland & Stewart Ltd
13. Kenneth Jay, *Calder Hall, the Story of Britain’s First Atomic Power Station*, 1956, Methuen & Co
14. PH Dawson and F Fidler, Wire wool type bearing failures: the formation of the wire wool, 1965, *Proc IMechE vol 180 part 1 no.1* p 513-530
15. F Dollin, Some design problems arising in the development of very large high-speed turbines, *Proc IMechE*, 1963, Vol. 177 no. 9 p 221 – 267
16. A Chitty, MR Graham and MC Murphy, The bending of large rotor forgings in service due to lateral differences in creep rate, *Iron and Steel*, April 1971, p 95 – 102
17. JM Mitchell and J Grant, Design and fluid dynamic development of steam turbine blading, *Proc First Parsons International Turbine Conference, IMechE*, 25th – 26th June 1984, p 81 – 91
18. J Grant and D Borthwick, Fully three-dimensional inviscid flow calculations for the final stage of a large low pressure steam turbine, *Proc Conf. Turbomachinery – Efficiency Prediction and Improvement, IMechE*, 1st – 3rd September 1987, p 305 – 311
19. J Grant, NB Wood and PT Walters, Development and site evaluation of some blading retrofit packages for improving the efficiency of low pressure turbines in UK power stations, *Proc Conf Turbomachinery: Latest Developments in a Changing Scene, European conference*, 1991-03, London, 19-20 March 1991
20. P Hopkins, AD Batte and MC Murphy, The fatigue of large rotating shafts, *Institute of Physics Stress Analysis Group Meeting on Fatigue in Service and the Role of Testing*, London, 4th October 1979.
21. ST Fenton and P Mulvihill, The investigation of defects and failures on power plant, *Operation Maintenance and Materials Issues*, Vol 3, Issue 2, August 2004, European Technology Development Ltd, Ashtead, Surrey, UK.
22. EPRI Report no. TR-100979 Vol.4: Testing of superalloy bolt materials for advanced power plants, *Research Project 1403-15*, September 1992
23. SM Beech, SR Holdsworth, HG Mellor, DA Miller and B Nath, An assessment of alloy Nimonic 80A as a high temperature bolting material for advanced steam conditions, *Proc Int Conf on Advances in Materials Technology for Fossil Power Plants, Chicago*, 1987, ASM/EPRI, p 403 – 410.
24. A Marucco and B Nath, Influence of gamma prime volume fraction on ordering and rupture properties of alloy 80A bolting material, *Proc Conf on Performance of Bolting Materials in High Temperature Plant Applications, York*, 16th – 17th June 1994, IoM, p 294-305.

25. RP Kent, Investigations into Rex 500 / Inconel weld failures, Proc Conf on Welding of Creep Resistant Steels, the Welding Institute, Cambridge, 17th – 18th February 1970.
26. J Barford, G Willoughby, HG Mellor and PW Teare, Weldment cracking involving a complex creep-resisting steel, Proc Conf on Welding of Creep Resistant Steels, the Welding Institute, Cambridge, 17th – 18th February 1970.
27. Sir Francis Tombs, Economies of scale in electricity generation and transmission, 1978, Proc IMechE Vol 192 p 387-395.
28. GL Brooks, A short history of the CANDU nuclear power system, AECL, paper prepared for the Ontario Hydro demand/supply plan hearing January 1993.
29. WG Morison, Pickering Power Station, Proc IMechE 1975 Vol 189 p 117-128.
30. NC Parsons, The development of large wet steam turbines, 6th November 1972, Sir Charles Parsons Memorial Lecture, North East Coast Institution of Engineers and Shipbuilders.
31. JR Bolter, Design, development and operating experience with wet steam turbines, BNES Conference - Technology of turbine plant operating with wet steam, London 1988.
32. NC Parsons, JM Mitchell and P Richardson, Development of turbines and generators for large unit ratings, World Power Conference, Moscow, August 1968.
33. A Smith, Experimental development of wet steam turbines, Reyrolle Parsons Review Winter 1975-76, p 1-11.
34. Reyrolle Parsons in joint turbo-generator venture with US company, Parsons Journal Summer 1970 Vol 12 No.69 p 47.
35. WJ Kearton, Steam turbine theory and practice, 1966, Pitman
36. JD Denton, AM Wallis, D Borthwick, J Grant, and I Ritchey, The three-dimensional design of low aspect ratio 50% reaction turbines, 1996, Proc. IMechE Seminar on Latest advances in the aerodynamics of turbomachinery with special emphasis on unsteady flows.

Appendix A Dynamic scaling

This is a useful concept which has been used by steam turbine design engineers since the early 1900s. It may be explained as follows.

Imagine that we have an existing design of turbine rated, say, at 350 MW at 3,600 revs/min. Then consider that we wish to create an equivalent design running at a different speed, say 3,000 revs/min. To do this, we take the existing drawings and multiply every dimension by the ratio of the running speeds = $3,600 / 3,000 = 1.2$. Every linear dimension such as length, diameter, blade height, etc is increased by a factor of 1.2. All non-dimensional parameters such as the number of blade rows do not change. Having magnified the design until it is 1.2 times larger, it is then operated at 3,000 revs/min using the same inlet steam pressure and temperature and exhaust pressure as the original machine. Let's see what happens in terms of efficiency, stress, vibration characteristics and power output. We'll use some simplified principles here, but the same conclusions are reached if a more rigorous approach is followed.

Efficiency

The force produced by turbine blades is related to the rate of change in steam momentum through the moving blades ie changes in steam velocity and direction. The power produced by each stage equals the force multiplied by the distance moved per second = force x blade speed. When this is expressed mathematically, the efficiency of the blading is found to be strongly dependent upon the ratio of the blade speed U to the steam speed C_0 , [35].

The blade speed $U = \pi D \omega$ where D is the diameter of the blading and ω is the rotational speed in revs/sec. If the diameter D is increased and the rotational speed ω is reduced by a factor of 1.2, then the blade speed U remains constant when the turbine is scaled.

The steam speed C_0 depends upon the pressure ratio across each stage and the inlet temperature. If the no. of stages in the turbine remains constant and the steam pressure and temperature at inlet and the pressure at exhaust stay the same, then C_0 remains constant across each stage.

Consequently, the ratio U/C_0 is the same in each design, which means that the efficiency of the blading doesn't change significantly. Added to this, the tip clearance remains the same percentage of the flow area in each stage so factors such as tip leakage loss remain unchanged.

The scaled turbine should operate at approximately the same efficiency as the original design apart from the effect of second order factors such as Reynold's number.

Stresses

If the turbine rotors may be approximated to rotating cylinders, centrifugal stresses depend upon $\rho \omega^2 r^2$ where ρ is the density of steel, ω is the rotational speed and r is the radius of the rotor. Again, if the radius of the rotor is increased by 1.2 and the speed is reduced by the same factor, then the product $\rho \omega^2 r^2$ stays constant.

If the casing and pipes are approximated to simple tubes, the pressure stress is nominally equal to $PD/2t$ where P is the pressure difference across the wall, D is the inside diameter and t is the thickness of the tube. So if D and t both increase by a factor 1.2, then the pressure stress stays constant.

These are highly simplified examples purely for discussion purposes, but the same principles apply when the stresses are calculated using more complex equations. Essentially, when a turbine is scaled to a different speed, the stresses generally stay constant except for thermal stress and rotor bending stress. The 3,000 rev/min design is 1.2 times larger, so transient thermal stresses are moderately higher due to the increased section thicknesses. The bending stress in each rotor rises because the weight of the shaft increases by more than the bending modulus. These effects tend to be secondary and do not prevent designers from using dynamic scaling.

Vibration

Blades are often visualised as cantilevered beams projecting from the root fixing. The vibration frequencies of a cantilever beam depends upon width / length². If width and length are scaled by a factor of 1.2, the vibration frequencies reduce by 1.2.

The natural frequencies of a scaled 3,000 revs/min blade should be 1.2 times lower than the 3,600 revs/min reference blade. However, the running speed of the machine is also 1.2 times lower. This means that the blade maintains the same margin between vibration frequency and running speed. This is important, since most of the factors which may excite blade vibration are related to multiples of running speed.

Again, this is just one example and a simplistic argument has been used to illustrate the principle, but a rigorous derivation shows this behaviour occurs in real turbines. Scaled turbines maintain the same vibration margins as the original design.

Power output

In simple terms, the power output of turbine = $m \eta \Delta H_a$ where m = the mass flow rate of steam, η = the stage efficiency and ΔH_a = the available energy per kg from the steam (the 'heat drop'). We have already seen that the efficiency η remains constant when the turbine is scaled. Also, the heat drop ΔH_a stays constant because the machines operate with the same inlet and exhaust steam conditions.

So what happens to the mass flow rate m ?

The mass flow rate is determined by the flow area of each stage $A = \pi D h O/P$ approximately where D = mean diameter of the blades, h = blade height, O = blade throat opening and P = blade pitch. When the unit is scaled, the ratio O/P stays constant, but D and h both increase by 1.2, so the term $D h$ increases by $1.2 \times 1.2 = 1.44$. Therefore, the flow area of each stage increases by a factor 1.44. This means that the mass flow rate will be 1.44 times higher with valves wide open (if the boiler is large enough) and so, the power output increases to $1.44 \times 350 = 504$ MW.

For this reason, it is said that a 350 MW turbine running at 3,600 revs/min operates at the same stress levels and thermodynamic load ie it is dynamically equivalent to a 500 MW turbine operating at 3,000 revs/min.

Turbine design engineers frequently make use of this principle. For example, once an LP turbine blade has been designed for one speed, it is usually scaled to produce equivalent designs for all of the popular speeds: 3,600, 3,000, 1,800 and 1,500 revs/min. In development work, model turbines may be used to investigate flow behaviour and to give an initial performance measurement for new blading types. At Parsons, experimental turbines were usually either one third full size running at 9,000 revs/min or quarter scale operating at 12,000 revs/min.

Appendix B Nomenclature

400 series	The name of a standard reaction blade aerofoil developed by Parsons around 1900.
600 series	The name of a standard reaction blade aerofoil first developed around 1926 and which was adopted in production turbines from 1933 onwards.
AC	Alternating current
AEI	Associated Electrical Industries
Aeolipile	Name given to Hero of Alexandria's turbine
AECL	Atomic Energy of Canada Ltd
AERE	UK Atomic Energy Research Establishment
AGR	Advanced gas-cooled nuclear reactors
APC	Atomic Power Constructions
BEA	British Electricity Authority

BFPT	Boiler feed pump turbine
Bypass governing	A control system which used an extra inlet valve to bypass the first blade group and so increased the steam flow rate through the turbine to produce more power. This was used to reduce valve throttling losses in turbines which operated with constant pressure boilers.
CADCAM	Computer aided design and manufacture
CANDU	Canadian Deuterium Uranium nuclear reactor
CEA	Central Electricity Authority.
CEGB	Central Electricity Generating Board.
CFD	Computational fluid dynamics
CNC	Computer numerically controlled machine tools
C_0	Speed of the steam leaving the fixed blades or nozzles in m/sec
Cross-compound	A turbine with more than one cylinder where the cylinders were arranged on separate shaft lines.
D	Shaft diameter
DC	Direct current
Disc construction	A turbine rotor where large discs were shrunk onto a narrow central shaft
DISCO	Newcastle and District Electric Lighting Company
Dummy piston	A step in the diameter of a turbine shaft with higher pressure on one side than the other which produced a force in the axial direction to counterbalance the axial forces created in the blade path.
Duplex turbine	A single cylinder turbine with two LP blading flows mounted on one shaft.
Dynamic scaling	A method which may be used to compare turbines running at different speeds to see which design was more technically advanced, appendix A.
End tightening	Turbine blades with an axial sealing fin where the clearance of the sealing fin could be adjusted while the turbine was running.
ESV	Emergency stop valve
GE	General Electric – an American manufacturer.
GEC	General Electric Company – a British manufacturer.

GS	Generating station
GT	Gas turbine
GV	Governing valve ie the valve(s) which throttled the steam flow entering the turbine and so controlled the power output.
Heat rate	The energy supplied to the steam by the boiler divided by the electrical energy produced by the generator.
HEPC	Hydro Electric Power Commission of Ontario
HL series	A variant of the R series blade aerofoil for high stage loading applications in machines from 30 to 100 MW at 3,000 revs/min.
hp	Horsepower
HP	High pressure
IFR	Integral formed root. A blade construction in which each blade was machined from forged bar with integral root fixing and shroud sections and with the aerofoil positioned on the edge of the bar before being brazed into segments.
ILS	Integral lozenge shroud. A blade construction in which each blade was machined from forged bar with integral root fixing and shroud sections and with the aerofoil positioned centrally on the bar before being brazed into segments.
Impulse turbine	A turbine in which the force on the moving blades was created solely by changing the direction of the steam flow through the blades.
IP	Intermediate pressure
LMZ	Leningradsky Metallichesky Zavod, a Russian manufacturer
LP	Low pressure
NEESCo	North East Electricity Supply Co
NEI	Northern Engineering Industries
NESCO	Newcastle Upon Tyne Electric Supply Company
Ni80A	Nimonic 80A, a nickel chromium superalloy
NNC	National Nuclear Corporation.
Nozzle governing	A control system where the first fixed blade row in the turbine was divided into separate groups or arcs of blades each supplied by a separate inlet valve. By opening each valve in sequence to increase the steam flow rate

and power output, valve throttling losses were minimised in turbines which operated with a constant pressure boiler.

NPPC	The Nuclear Power Plant Co.
PS	Power station
R-R	Rolls-Royce
R series	A standard reaction blade aerofoil developed using CFD in the mid-1980s.
Reaction turbine	A turbine in which the force on the moving blades was created by changing both the direction and the velocity of the steam as it passed through the blades.
RT series	A variant of the R series blade with a twisted aerofoil for the exhaust end blading in large IP turbines.
SC03	Finite element software received from Rolls-Royce for stress, deflection and vibration calculations.
SCF	Stress concentration factor
Secondary losses	Performance losses due to flow vortices formed within the blade passages close to the end walls.
SGHWR	Steam generating heavy water reactor
Sliding pressure	A control system which varied the boiler pressure in proportion to the pressure inside the turbine as it changed with load. This helped to avoid valve throttling losses which occurred at part loads if the boiler maintained constant pressure.
SS	Steam ship
SSEB	South of Scotland Electricity Board.
Tandem compound	A turbine with more than one cylinder in which the cylinders were arranged on a single shaft line.
TG	Turbine-generator
Thermal block	The gas turbine and steam turbine-generators which worked as a coordinated set of machines in a combined cycle power station.
Throttle governing	A control system where the turbine inlet valve was throttled to reduce the steam flow through the turbine and hence it's power output. If the boiler operated at constant pressure, then the pressure loss across the valve represented an efficiency loss which could be counteracted by using bypass governing, nozzle governing or sliding pressure instead.

TNPG	The Nuclear Power Group.
TVA	Tennessee Valley Authority
U	Speed of the moving blades in m/sec.
UKAEA	UK Atomic Energy Authority
Velocity ratio	The speed of the moving blades in a given blade row divided by the speed of the steam leaving the fixed blades or nozzles. This factor had a large effect on the efficiency of a turbine [35].
ω	Rotational speed revs/sec